

**ENERGY
SECTOR**
RENEWABLE
ENERGIES

*Over 40 years' tradition in
manufacturing safety and
reliable servosystems for
Renewable energies*

DUPLOMATIC
MOTION SOLUTIONS

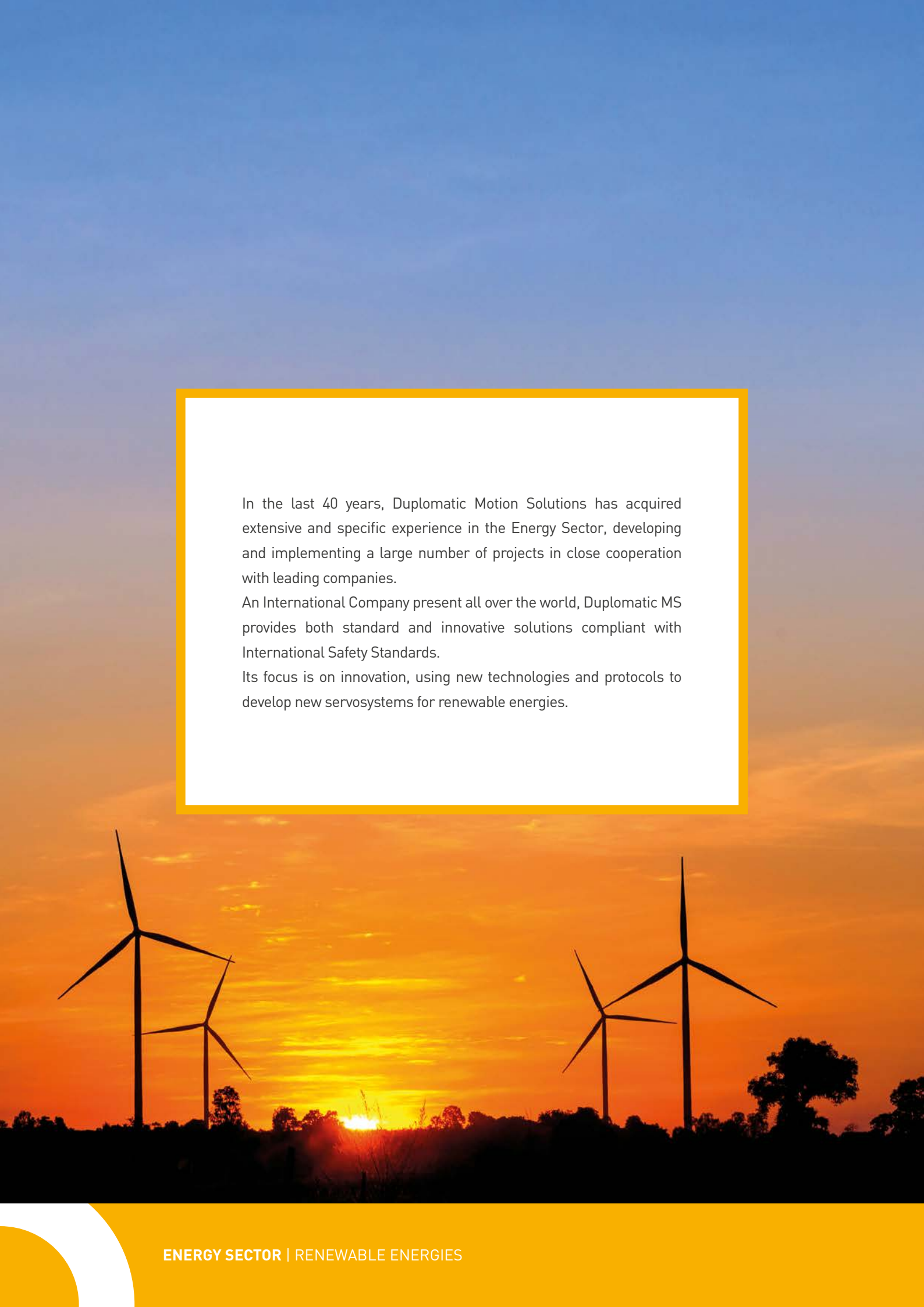

In the last 40 years, Diplomatic Motion Solutions has acquired extensive and specific experience in the Energy Sector, developing and implementing a large number of projects in close cooperation with leading companies.

An International Company present all over the world, Diplomatic MS provides both standard and innovative solutions compliant with International Safety Standards.

Its focus is on innovation, using new technologies and protocols to develop new servosystems for renewable energies.

Renewables look forward

Somewhere in the world water flows with endless forcefulness, and somewhere else the sun gives no respite; somewhere the wind blows all year round, and somewhere else the heat of our earth rises up warming the subsoil.

This natural power has shaped our world and represents for humanity the cleanest and least expensive source of energy.

Diplomatic offers a wide range of tailor-made solutions aimed at obtaining a part of this energy efficiently and in total safety: lubrication and power units, electromechanical and electrohydraulic actuators, trip blocks and key-in-hand packages ready for commissioning.



HYDRO POWER

Pelton, Kaplan and Francis turbines are the core of hydro power technology: their robust construction grants very long periods of unattended operation, and therefore provide the highest reliability in terms of automation and safety.

Duplomatic offers low pressure and high-pressure systems composed of power unit, actuators and control manifolds.

Key components with custom features, such as six-way flow diverter for fast emergency positioning and solenoid valves with lockable hand lever, join the cutting-edge servo proportional technology, making Duplomatic one of the top preferred brands for new installations and refurbishing.

ADVANTAGES

- *Tailor made execution*
- *Very high reliability*
- *Custom components*
- *Easy installation*

FEATURES

- *Painted carbon steel or stainless steel*
- *High and low pressure*

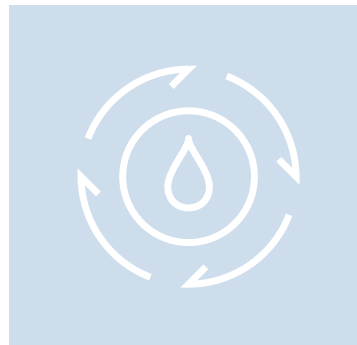
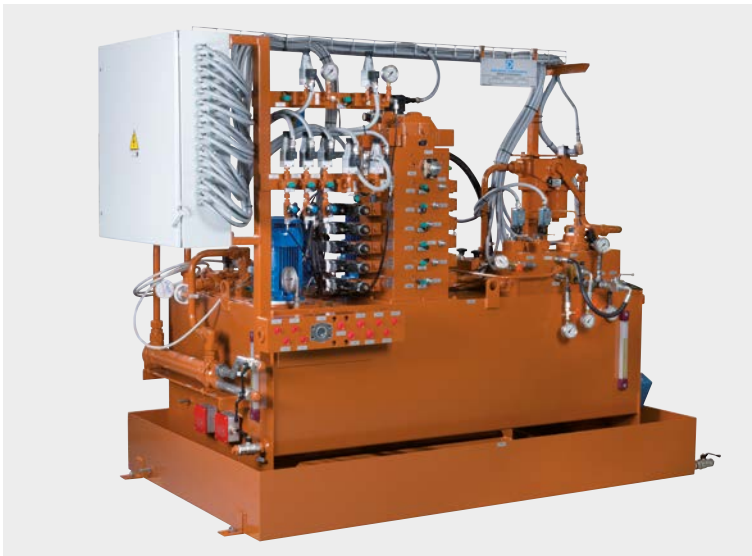
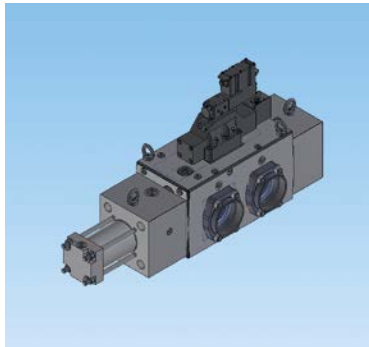
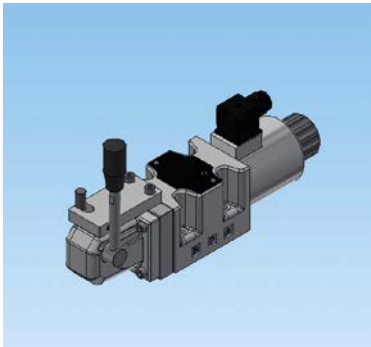

GEOHERMAL ORC

Wherever the heat of the earth rises up enough to be captured, an ORC turbine transforms the thermal energy into electrical energy.

Sometimes the low differential temperature available forces the use of flammable process fluids, and the environment becomes hazardous; quite often the presence of hydrogen sulfide and sulfur dioxide makes it necessary to take precautions to prevent corrosion.

Diplomatic has a long experience in geothermal installation and offers solutions that ensure high reliability and resistance.

The package includes power unit, spring return servoactuators, 2oo3 trip block, and if necessary, globe valves and dampers.

ADVANTAGES

- *Extremely low leakage*
- *Almost null hysteresis*
- *Custom mounting interface*
- *Custom sizing*

FEATURES

- *Safe and hazardous locations*
- *Aggressive environment*
- *Servoactuators SIL2*
- *Trip block SIL3*

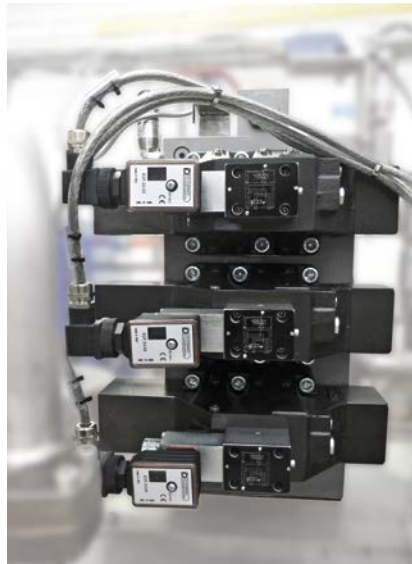

SOLAR TRACKING

Different concepts with different efficiencies are nowadays available for sun tracking collectors that concentrate the solar heat on a receiver.

Diplomatic owns the highest efficient architecture available, that includes power unit, cylinders, control blocks and driving electronics to continuously concentrate the solar energy on the receivers with accuracy within +/- 0.8 mrad.

Besides the best accuracy, the solution grants the safe recovery of the mirrors in the event of high wind speed, suitable for harsh environments such deserts and coasts.

ADVANTAGES

- *Key-in-hand solution*
- *Highly accurate*
- *Fail safe positioning*

FEATURES

- *Harsh environment*
- *Very low power installed*
- *Continuous tracking*

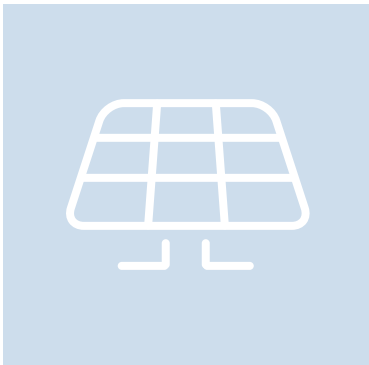

WIND POWER

Wind towers operate unattended on shore and off shore, and sometimes in critical environments: that is why they require the highest possible reliability of their control automation.

Blade pitch control systems are a main feature in wind turbine operations. There are mainly two reasons for this:

- Efficiency, i.e. to maximize energy production and reduce loads on wireframe.
- Safety and reliability, i.e. to prevent overload by quickly turning and locking the blades in a neutral angle position in case of overspeed or energy issue.

Diplomatic offers both electro-hydraulic and electro-mechanical actuation systems for pitch controlling.

Each system grants the best accuracy and fail safe positioning.

ADVANTAGES

- *Electro-mechanical actuation*
- *Electro-hydraulic actuation*
- *High efficiency*
- *Fail safe function*
- *Custom sizing*

FEATURES

- *Critical environment*
- *SIL2*

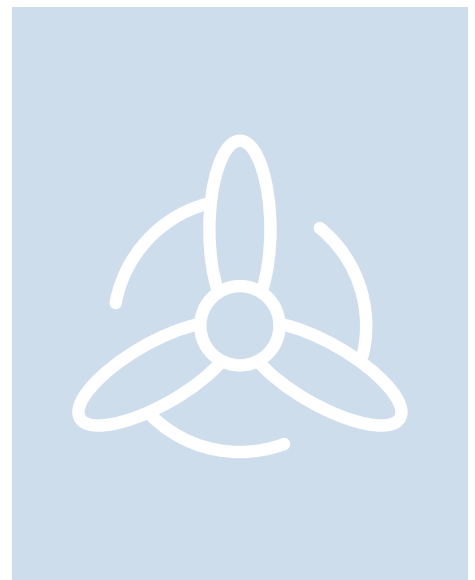

DIPLOMATIC GROUP

a global presence with production plants in 3 continents.



Diplomatic MS S.p.A.
via Mario Re Depaolini, 24
20015 Parabiago (MI) - Italia

T +39 0331 895111 E sales.exp@diplomatic.com
www.diplomatic.com
Follow us on  Diplomatic Motion Solutions