



PDE3J*

PROPORTIONAL PRESSURE CONTROL VALVE, WITH PRESSURE FEEDBACK AND INTEGRATED ELECTRONICS

SUBPLATE MOUNTING
ISO 4401-03

p max **350** bar
Q max **2** l/min

MOUNTING INTERFACE

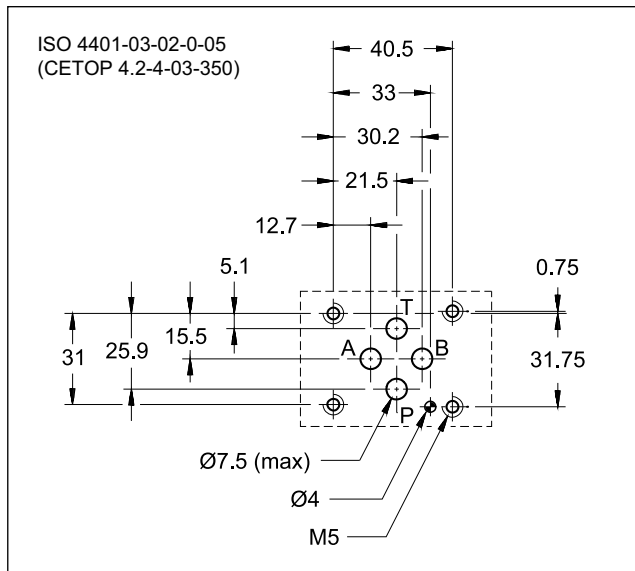

OPERATING PRINCIPLE

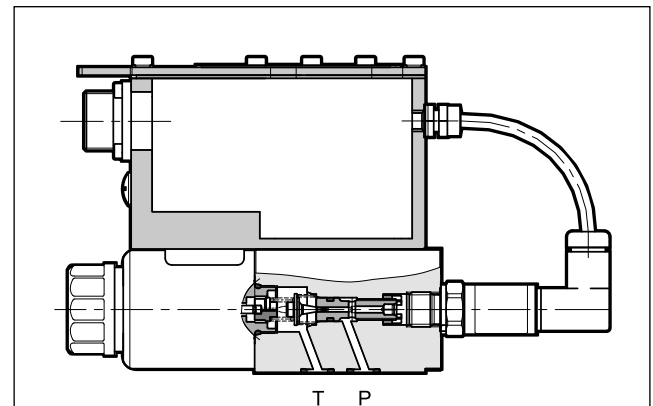

- The PDE3J* is a direct operated proportional pressure control valve with pressure feedback and mounting interface in compliance with ISO 4401 standards.
- It is suitable to pilot two-stage valves, for pressure control in hydraulic circuits.
- It is available with different types of electronics, with analogue or fieldbus interfaces.

PERFORMANCES

(obtained with mineral oil with viscosity of 36 cSt at 50°C and p = 140 bar)

Maximum operating pressure: - P port - T port	bar	350 2
Nominal flow Maximum flow (see p min= f(Q) diagram)	l/min	1 2
Step response	see point 7	
Hysteresis	% of p nom	< 1%
Repeatability	% of p nom	< ±0,5%
Electrical characteristic	see point 2	
Ambient temperature range	°C	-20 / +60
Fluid temperature range	°C	-20 / +80
Fluid viscosity range	cSt	10 ÷ 400
Fluid contamination degree	According to ISO 4406:1999 class 18/16/13	
Recommended viscosity	cSt	25
Mass	kg	2,5

- The monitoring of the value detected by the pressure transmitter is available on pin F.
- Three pressure adjustment ranges are available up to 350 bar .
- The valve is easy to install. The driver manages digital settings directly.

HYDRAULIC SYMBOL

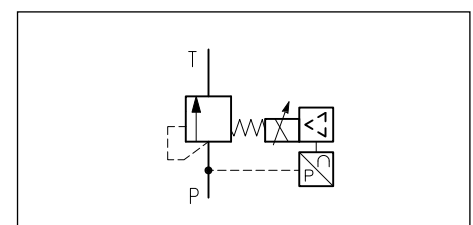

1 - IDENTIFICATION CODE

1.1 - Standard electronics

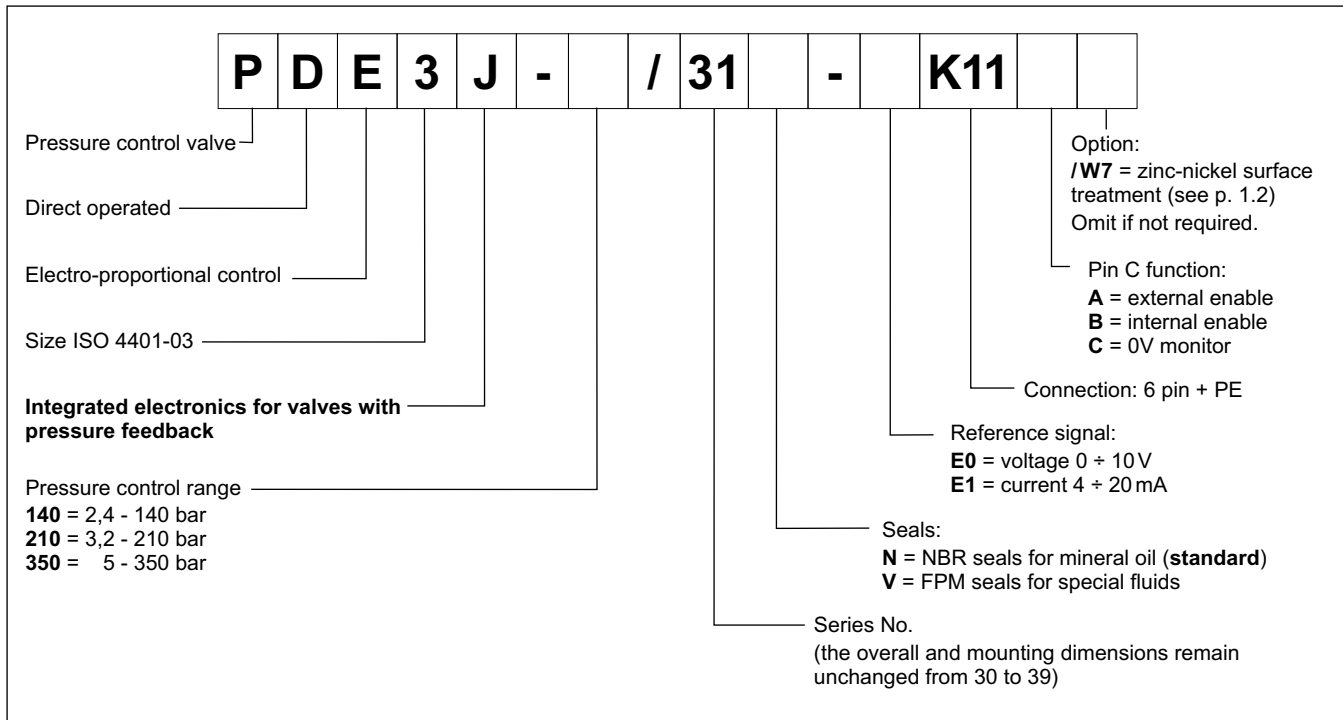

1.2 - Surface treatments

The standard valve is supplied with surface treatment of phosphating black. The zinc-nickel finishing on the valve body makes the valve suitable to ensure a salt spray resistance up to 240 hours. (test operated according to UNI EN ISO 9227 standards and test evaluation operated according to UNI EN ISO 10289 standards).

1.3 - Compact electronics

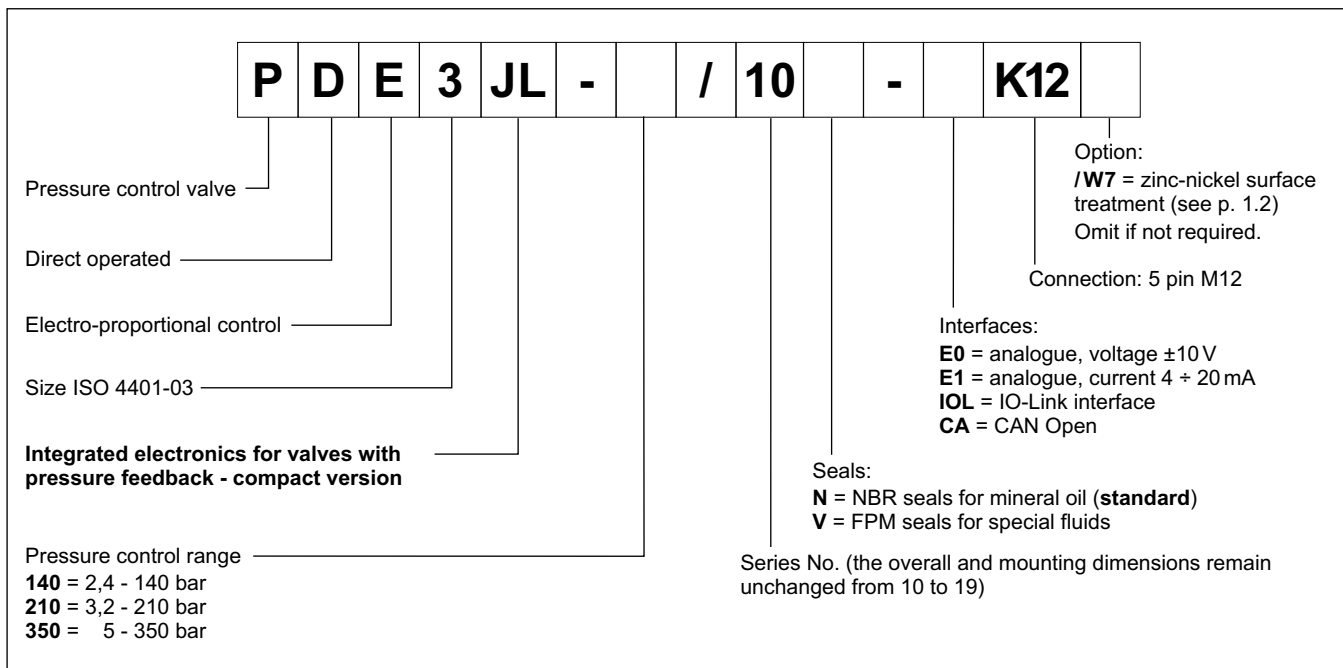

1.4 - Electronics with fieldbus communication

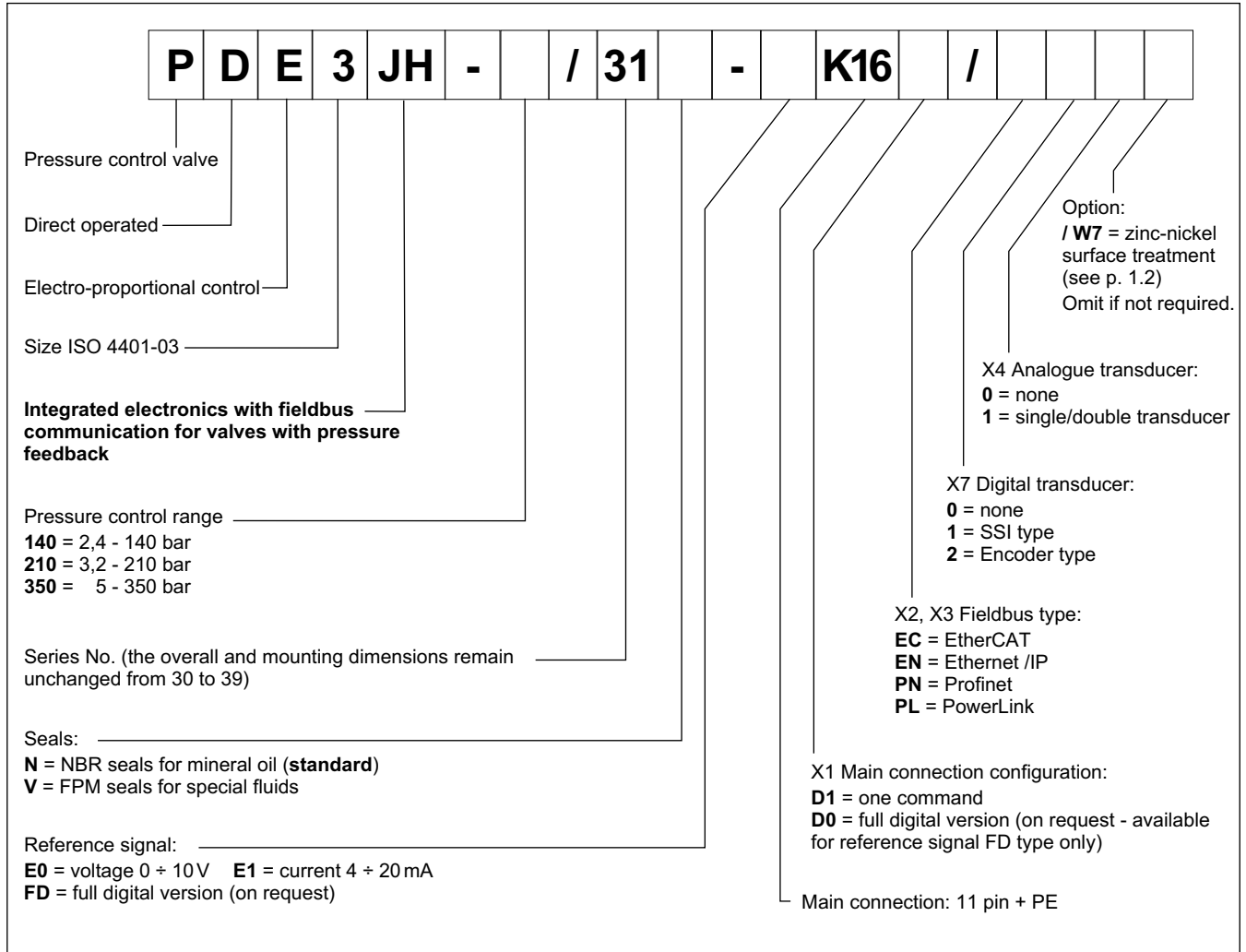

2 - ELECTRONICS COMMON DATA

Duty cycle		100% (continuous operation)
Protection class according to EN 60529		IP65/IP67 (NOTE)
Supply voltage	V DC	24 (from 19 to 30 VDC), ripple max 3 Vpp
Power consumption	VA	25
Maximum solenoid current	A	1.88
Fuse protection, external	A	2A time lag
Managed breakdowns		Overload and electronics overheating, cable breakdown, supply voltage failures
Electromagnetic compatibility (EMC) emissions EN 61000-6-4, immunity EN 61000-6-2		According to 2014/30/EU standards

NOTE: The IP degree is guaranteed only with mating connector of equivalent IP degree, installed and tightened correctly. Moreover, on the JH versions it is necessary to protect with caps any unused connections.

3 - PDE3J - STANDARD ELECTRONICS

3.1 - Electrical characteristics

Command signal:	voltage (E0) current (E1)	V DC mA	0 ÷ 10 (Impedance Ri = 11 kOhm) 4 ÷ 20 (Impedance Ri = 58 Ohm)
Monitor signal (pressure at transducer):	voltage (E0) current (E1)	V DC mA	0 ÷ 10 (Impedance Ro > 1 kOhm) 4 ÷ 20 (Impedance Ro = 500 Ohm)
Communication for diagnostic			LIN-bus Interface (by means of the optional kit)
Connection			6 pin + PE (MIL-C-5015-G - DIN EN 175201-804)

3.2 - On-board electronics diagrams

VERSION A - External Enable

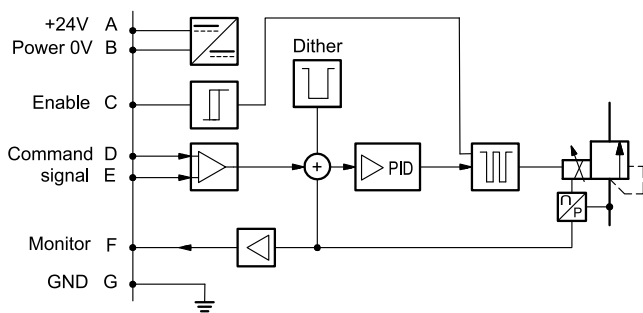

VERSION B - Internal Enable

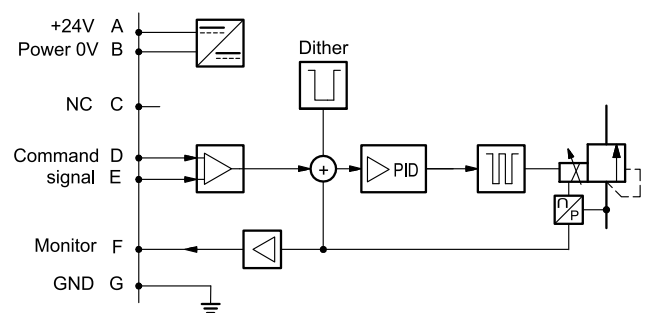

VERSION C - 0V Monitor

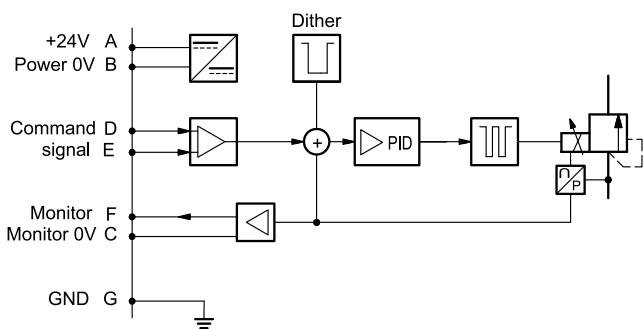

3.3 - Version with voltage command (E0)

The reference signal is between 0 ÷ 10V. The monitor feature of versions B and C becomes available with a delay of 0,5 sec from the power-on of the card.

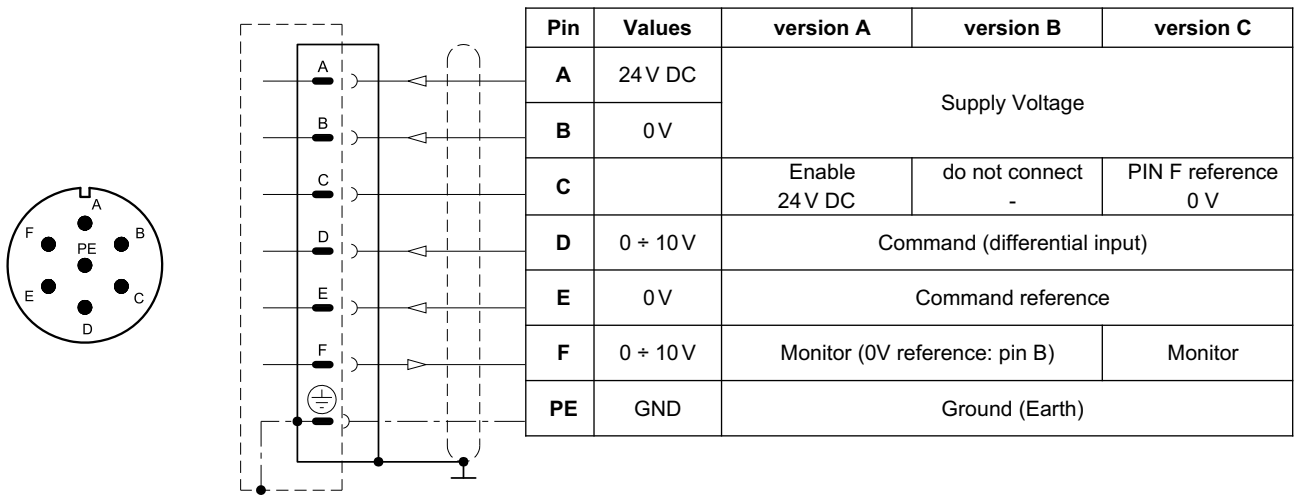
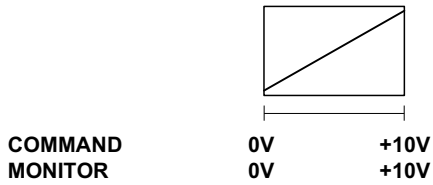

3.4 - Versions with current command (E1)

The reference signal is supplied in current 4 ÷ 20 mA. If the current for command is lower, the card shows a breakdown cable error. To reset the error is sufficient to restore the signal.

The monitor feature of versions B and C becomes available with a delay of 0,5 sec from the power-on of the card.

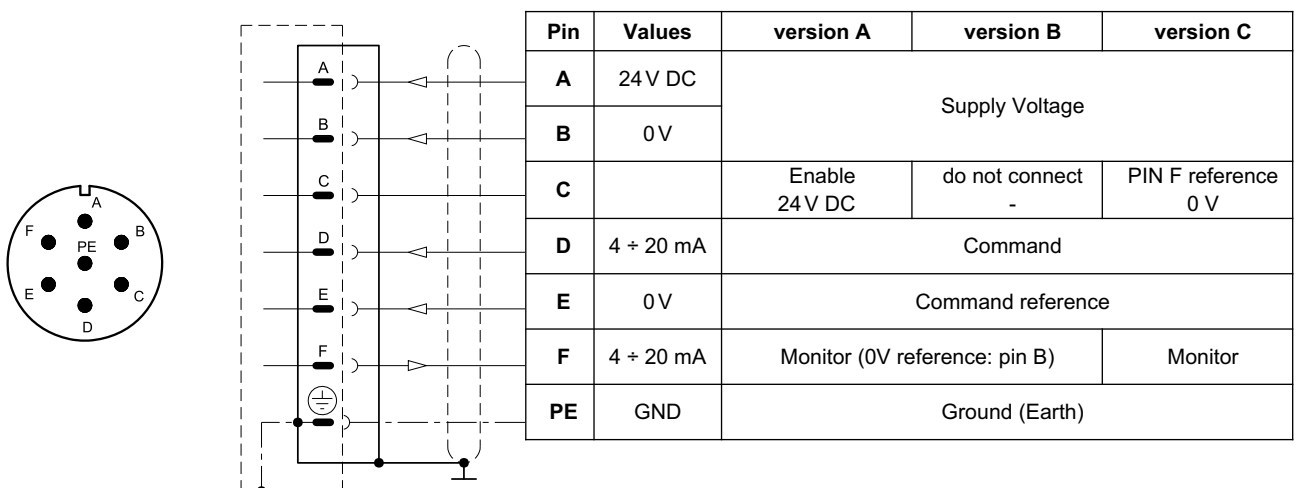
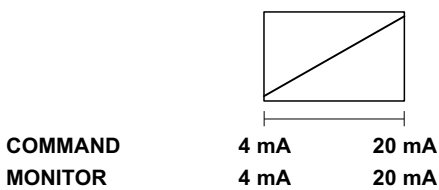

4 - PDE3JL - COMPACT ELECTRONICS

In versions 'IOL' and 'CA' pin 3 and pin 5 are galvanic isolated up to 100 V to avoid earth loops. In IO-Link networks, the length of the connecting cables is limited to 20 metres.

4.1 - Electrical characteristics

Command signal: voltage (E0) current (E1)	V DC mA	0 ÷ 10 (Impedance Ri = 11 kOhm) 4 ÷ 20 (Impedance Ri = 58 Ohm)
Monitor signal (pressure at transducer): voltage (E0) current (E1)	V DC mA	0 ÷ 5 (Impedance Ro > 1 kOhm) 4 ÷ 20 (Impedance Ro = 500 Ohm)
IO-Link communication (IOL): Data rate	kBaud	IO-Link Port Class B 230.4
Can Open communication (CA): Data rate	kbit	10 ÷ 1000
Data register (IOL and CA versions only)		solenoid voltage supply, solenoid faults (shortcircuit, bad config, internal), box temperature, switch-on time, vibrations
Connection		5-pin M12 code A (IEC 61076-2-101)

4.2 - Pin tables

'E0' connection



Pin	Values	Function
2	24 V DC	Supply voltage (solenoid and logic)
5	0 V	
1	0 ÷ 10 V	Command
3	0 V	Command reference
4	0 ÷ 5 V	Monitor (0V reference: pin 5)

'E1' connection



Pin	Values	Function
2	24 V DC	Supply voltage (solenoid and logic)
5	0 V	
1	4 ÷ 20 mA	Command
3	0 V	Command reference
4	4 ÷ 20 mA	Monitor (0V reference: pin 5)

'IOL' connection



Pin	Values	Function
2	2L+ 24 V DC	Supply of the power stage
5	2L- 0 V (GND)	Internal galvanic isolation from PIN 3
1	1L+ +24 V DC	IO-Link supply voltage
3	1L- 0 V (GND)	
4	C/Q	IO-Link Communication

'CA' connection



Pin	Values	Function
1	CAN_SH	Shield
2	24 V DC	Supply voltage
3	0 V (GND)	
4	CAN H	Bus line (high)
5	CAN_L	Bus line (low)

5 - PDE3JH - FIELD BUS ELECTRONICS

The 11+ PE pin connection allows separate supply voltage for electronics and solenoid. Command - valve position schemes as for the standard electronics. Please refer to pictures in point 3.3 and 3.4.

5.1 - Electrical characteristics

Command signal: voltage (E0) current (E1) digital (FD)	V DC mA	0 ÷ 10 (Impedance Ri = 11 kOhm) 4 ÷ 20 (Impedance Ri = 58 Ohm) via fieldbus
Monitor signal (pressure at transducer): voltage (E0) current (E1)	V DC mA	0 ÷ 10 (Impedance Ro > 1 kOhm) 4 ÷ 20 (Impedance Ro = 500 Ohm)
Communication / diagnostic		via Bus register
Communication interface standards		IEC 61158
Communication physical layer		fast ethernet, insulated 100 Base TX
Power connection		11 pin + PE (DIN 43651)

5.2 - X1 Main connection pin table

D1: one command				D0: full digital			
Pin	Values	Function	Pin	Values	Function		
1	24 V DC	Main supply voltage	1	24 V DC	Main supply voltage		
2	0 V		2	0 V			
3	24V DC	Enable	3	24V DC	Enable		
4	0 ÷ 10 V (E0) 4 ÷ 20 (E1)	Command	4	NC	do not connect		
5	0 V	Command reference signal	5	NC	do not connect		
6	0 ÷ 10 V (E0) 4 ÷ 20 (E1)	Monitor (0V reference pin 10)	6	NC	do not connect		
7	NC	do not connect	7	NC	do not connect		
8	NC	do not connect	8	NC	do not connect		
9	24 V DC	Logic and control supply	9	24 V DC	Logic and control supply		
10	0 V		10	0 V			
11	24 V DC	Fault (0V DC) or normal working (24V DC) (0V reference pin 2)	11	24 V DC	Fault (0V DC) or normal working (24V DC) (0V ref. pin 2)		
12	GND	Ground (Earth)	12	GND	Ground (Earth)		

5.3 - FIELD BUS connections

Please wire following guidelines provided by the related standards communication protocol. Any connections present and not used must be protected with special caps so as not to nullify the protection against atmospheric agents.

X2 (IN) connection M12 D 4 pin female



Pin	Values	Function
1	TX+	Transmitter
2	RX+	Receiver
3	TX-	Transmitter
4	RX-	Receiver
HOUSING	shield	

X3 (OUT) connection: M12 D 4 pin female



Pin	Values	Function
1	TX+	Transmitter
2	RX+	Receiver
3	TX-	Transmitter
4	RX-	Receiver
HOUSING	shield	

NOTE: Shield connection on connector housing is recommended.

5.4 - Digital transducer connection

X7 connection: M12 A 8 pin female

VERSION 1: SSI type

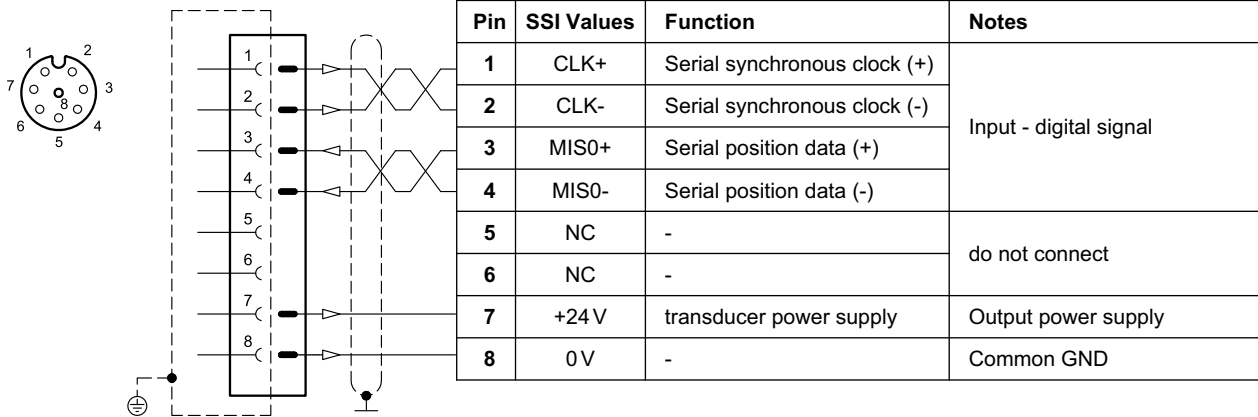

VERSION 2: ENCODER type

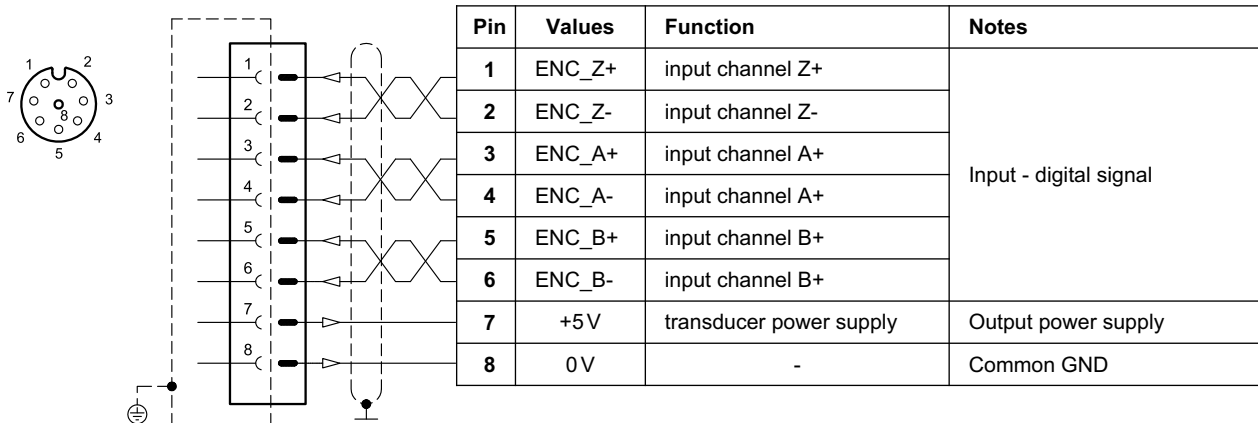

5.5 - Analogue transducer connection

X4 connection: M12 A 4 pin female

VERSION 1: single / double transducer

(single or double is a software-selectable option)

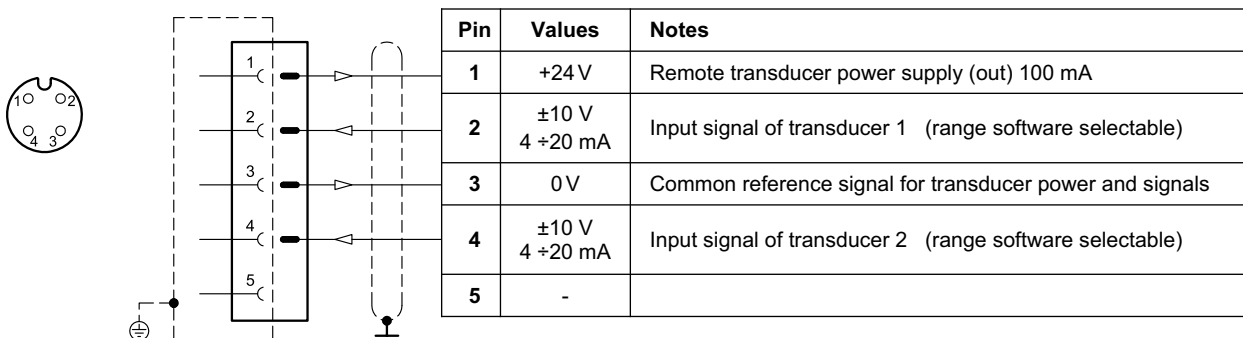

6 - CHARACTERISTIC CURVES

(measured with viscosity of 36 cSt at 50°C)

Typical control characteristics, according to the reference signal for available pressure control ranges, measured with input flow rate $Q = 1 \text{ l/min}$.

Characteristic curves measured without backpressure in T, with linearity and hysteresis compensation set by the onboard electronics.

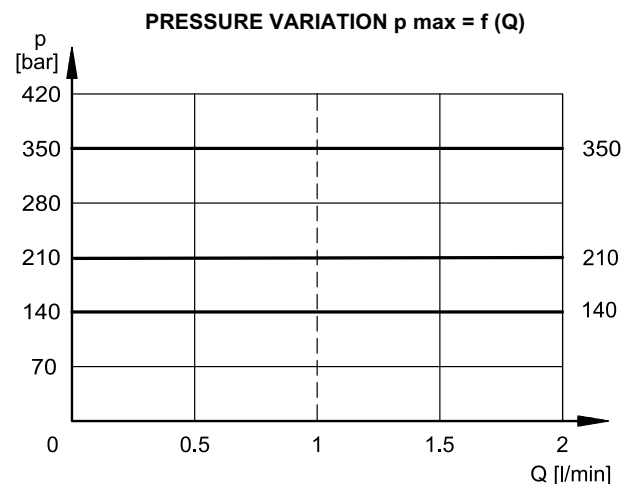
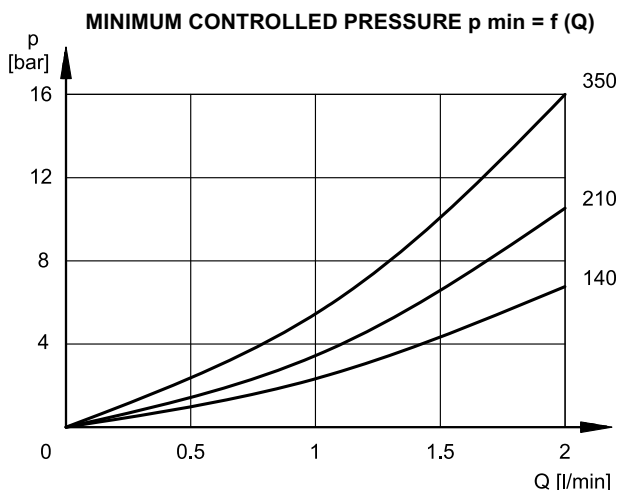
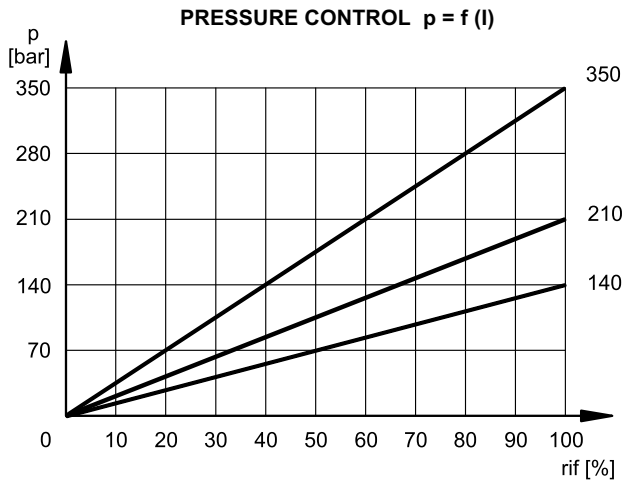

7 - STEP RESPONSE

(obtained with mineral oil with viscosity of 36 cSt at 50°C and electronic control card)

Step response is the time taken for the valve to reach 90% of the set pressure value following a step change of reference signal.

The table illustrates typical step response times measured with a PDE3J-210 and with an input flow rate of $Q = 1 \text{ l/min}$ and pressure oil volume of 0,1 litre.

The response time is affected both by the flow rate and the oil volume in the pipework.

REFERENCE SIGNAL STEP	0 → 100%	100 → 0%
Step response [ms]	60	20

8 - PDE3J - OVERALL AND MOUNTING DIMENSIONS

dimensions in mm

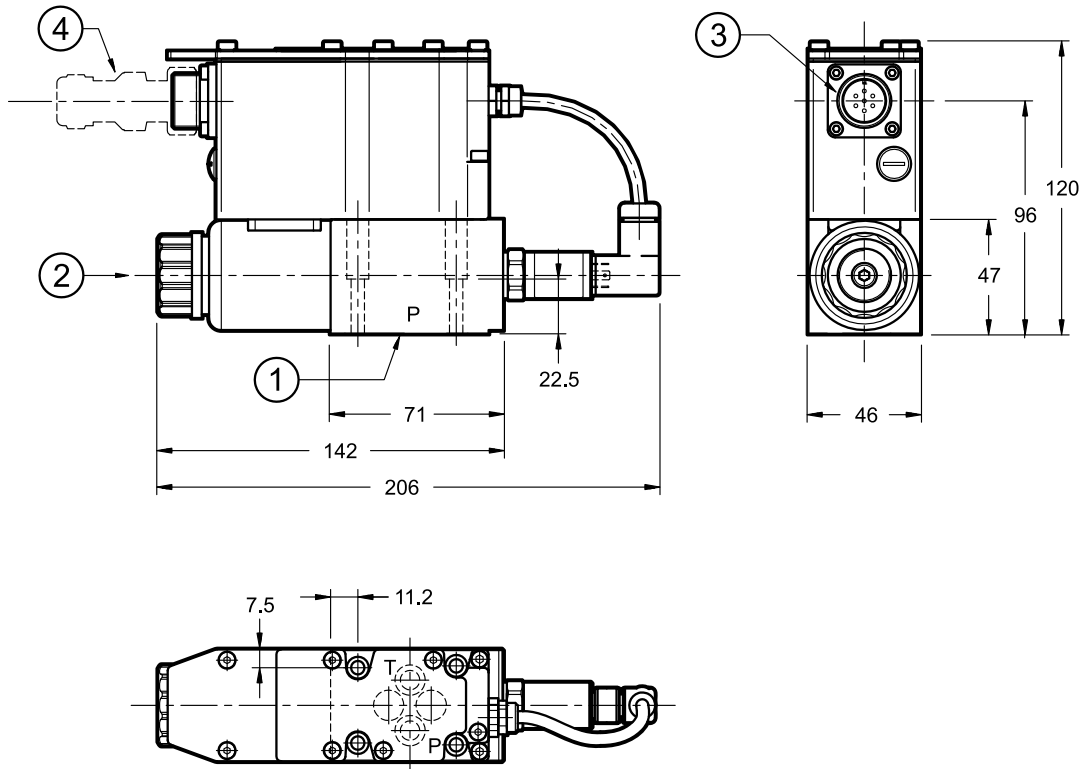

NOTE: at the first start up, or after a long period of no use, it is necessary to vent the air through the breather (2) placed at the end of the solenoid tube.

1	Mounting surface with sealing rings: 4 OR type 2037 (9.25x1.78) - 90 shore
2	Breather: Allen key 4
3	Main connection
4	Mating connector 6 poles + PE , female type MIL-5015-G To be ordered separately. See catalogue 89 000

Fastening bolts: 4 SHC screws M5x30- ISO 4762

Torque: 5 Nm (A8.8)

Threads of mounting holes: M5x10

9 - PDE3JL - OVERALL AND MOUNTING DIMENSIONS

dimensions in mm

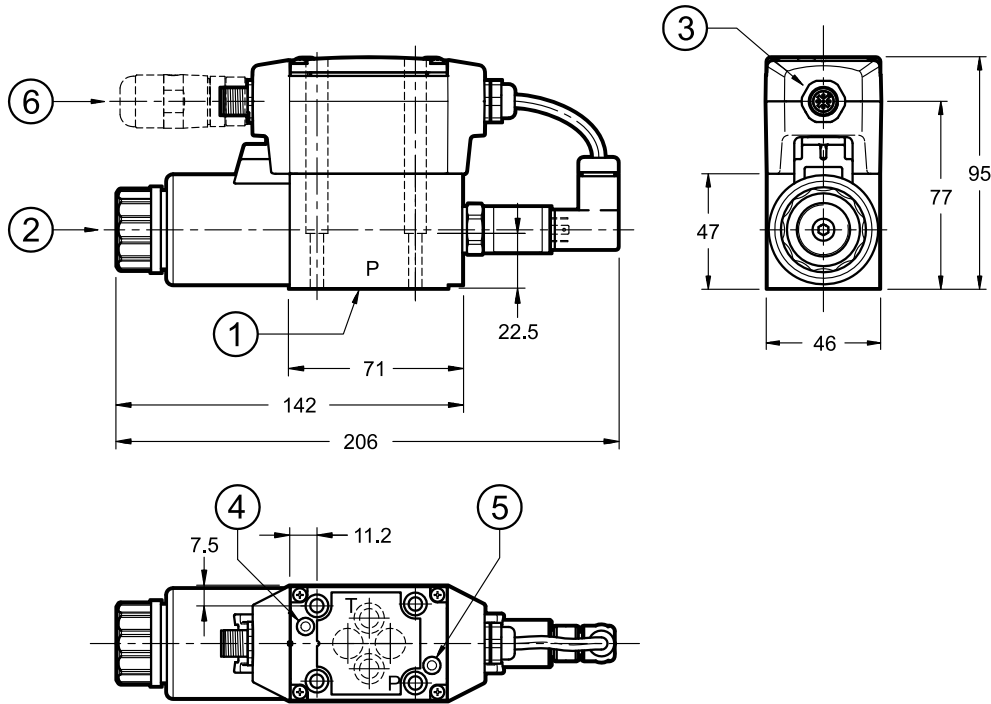

NOTE: at the first start up, or after a long period of no use, it is necessary to vent the air through the breather (2) placed at the end of the solenoid tube.

Fastening bolts: 4 SHC screws M5x30- ISO 4762

Torque: 5 Nm (A8.8)

Threads of mounting holes: M5x10

1	Mounting surface with sealing rings: N. 4 OR type 2037 (9.25x1.78) 90 Shore
2	Breather: Allen key 4
3	Connection M12 A 5 pin
4	L1 LED
5	L2 LED
6	Mating connector M12 5 poles - code A, female To be ordered separately. See catalogue 89 000

10 - PDE3JH - OVERALL AND MOUNTING DIMENSIONS

dimensions in mm

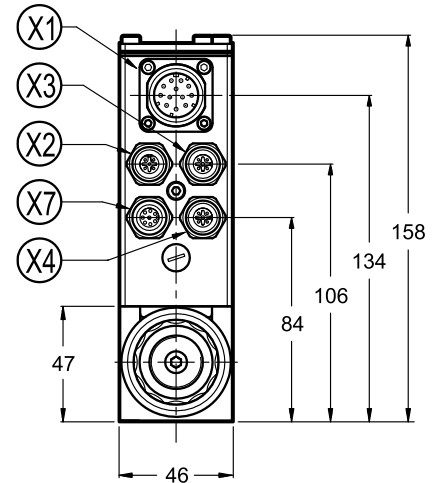
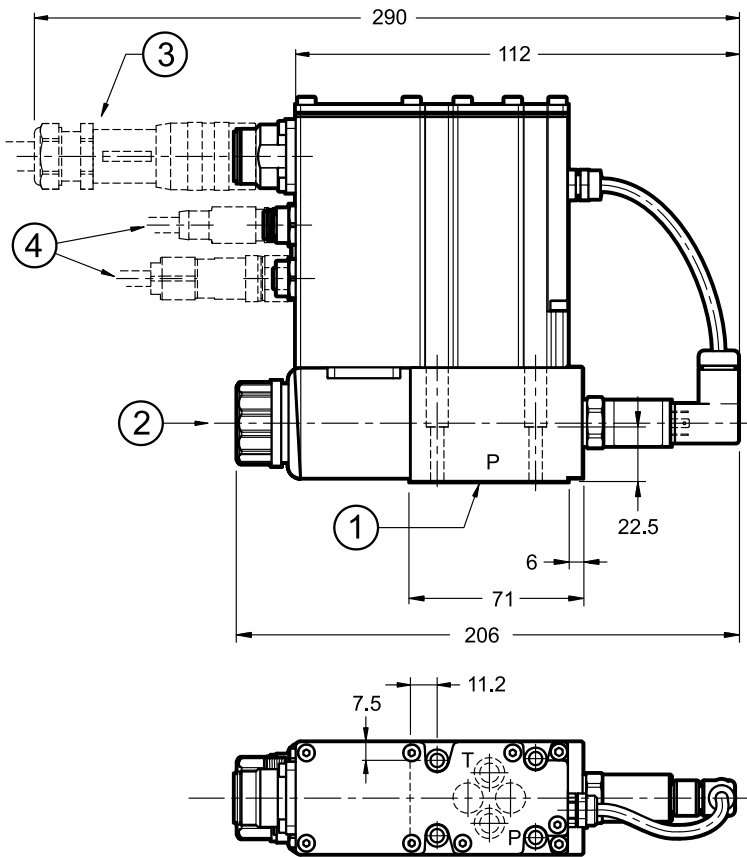

X1	Main connection 11 pin + PE
X2	Fieldbus communication (IN)
X3	Fieldbus communication (OUT)
X4	X4 connection for analogue transducer
X7	X7 connection for digital transducer

1	Mounting surface with sealing rings: N. 4 OR type 2037 (9.25x1.78) 90 Shore
2	Breather: Allen key 4
3	Mating connector 11 poles + PE To be ordered separately. See catalogue 89 000
4	Mating connectors for fieldbus communication and signals To be ordered separately. See catalogue 89 000

NOTE 1: Depending on the chosen version, X4 and X7 connections may not be present.
Please refer to section 5 for connection descriptions and pinout.

NOTE 2: at the first start up, or after a long period of no use, it is necessary to vent the air through the breather (2) placed at the end of the solenoid tube.

Fastening bolts: 4 SHC screws M5x30
ISO 4762

Torque: 5 Nm (A8.8)

Threads of mounting holes: M5x10

11 - HYDRAULIC FLUIDS

Use mineral oil-based hydraulic fluids HL or HM type, according to ISO 6743-4. For these fluids, use NBR seals. For fluids HFDR type (phosphate esters) use FPM seals (code V). For the use of other kinds of fluid such as HFA, HFB, HFC, please consult our technical department.

Using fluids at temperatures higher than 80 °C causes a faster degradation of the fluid and of the seals characteristics. The fluid must be preserved in its physical and chemical characteristics.

12 - INSTALLATION

We recommend installing these valves with the solenoid downward, either in horizontal or vertical position. If the valve is installed on vertical axis with the solenoid upward, you should consider possible variations of the minimum controlled pressure from those indicated in point 5.

Ensure that there is no air in the hydraulic circuit. In certain applications it might be necessary to vent the air entrapped in the solenoid tube by unfastening the drain screw placed in the solenoid tube.

Ensure the solenoid tube is always filled with oil. Make sure the drain screw has been put back correctly at the end of the task. Connect the valve T port directly to the tank.

Add any backpressure value detected in the T line to the controlled pressure value. Maximum admissible backpressure in the T line, under operational conditions, is 2 bar.

Valves are fixed by means of screws or tie rods on a flat surface with planarity and roughness equal to or better than those indicated in the relative symbols.

If minimum values are not observed, fluid can easily leaks between the valve and support surface.

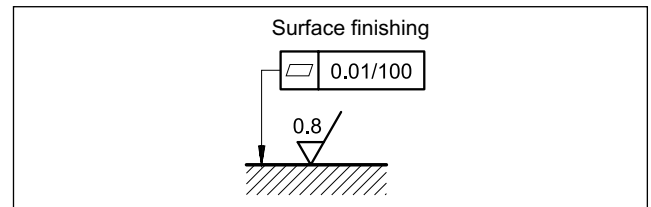

13 - ACCESSORIES

(to be ordered separately)

13.1 - Mating connectors

Mating connectors must be ordered separately. See catalogue 89 000.



For K11 and K16 versions we recommend the choice of a metal connector to avoid electromagnetic disturbances and to comply with EMC regulations on electromagnetic compatibility. If you opt for a plastic connector, make sure that it guarantees and maintains the IP and EMC protection characteristics of the valve.

13.2 - Mating connectors and caps for fieldbus communication and for sensors.

Duplomatic offers spare parts to be wired and also ready-to-use cord sets. Please refer to cat. 89 000.

13.3 - Connection cable

The optimal wiring provides for 7 isolated conductors, with separate screen for the signal wires (command, monitor) and an overall screen.

Cross section for power supply:

- up to 20 m cable length : 1,0 mm²
- up to 40 m cable length : 1,5 mm² (IO-Link excluded)

Cross section for signals (command, monitor):

- 0,50 mm²

13.4 - Kit for start-up LINPC-USB

Device for service start-up and diagnostic. See catalogue 89 850.

14 - SUBPLATES

(see catalogue 51 000)

PMMD-AI3G rear ports
PMMD-AL3G side ports
Ports dimensions: P, T, A, B: 3/8" BSP



PDE3J*



DIPLOMATIC MS S.p.A.

via M. Re Depaolini 24 • 20015 PARABIAGO (MI) • ITALY

tel. +39 0331.895.111 • www.diplomatic.com • e-mail: sales.exp@diplomatic.com