



# DS3GL

## SOLENOID OPERATED DIRECTIONAL VALVE WITH DIGITAL INTERFACE

SERIES 10

### SUBPLATE MOUNTING ISO 4401-03

p max **350** bar

Q max **80** l/min

### MOUNTING INTERFACE

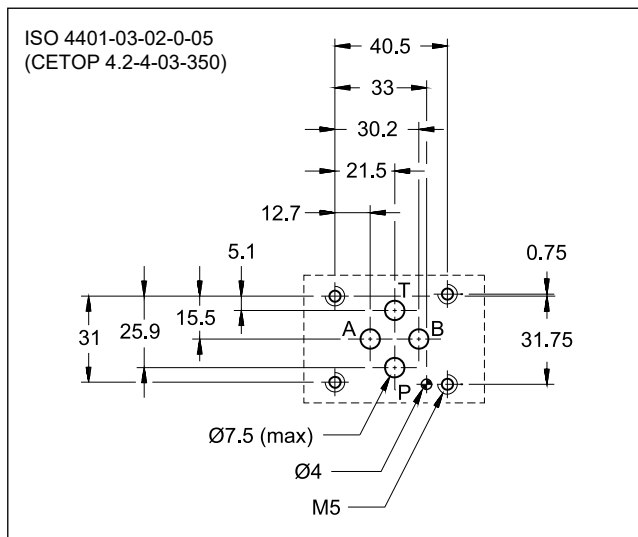

### PERFORMANCES

(obtained with mineral oil with viscosity of 36 cSt at 50°C)

Maximum operating pressure:			350
- P - A - B ports	bar		210
- T port			160
Maximum flowrate	l/min		80
Pressure drops $\Delta p$ -Q	see paragraph 5		
Operating limits	see paragraph 7		
Electrical features	see paragraph 8		
Electrical connection	M12 5 pin male A		
Ambient temperature range	°C		-20 / +50
Fluid temperature range	°C		-20 / +80
Fluid viscosity range	cSt		10 ÷ 400
Fluid contamination degree	according to ISO 4406:1999 class 20/18/15		
Recommended viscosity	cSt		25
Mass:		kg	
single solenoid valve			1,5
double solenoid valve			2

### OPERATING PRINCIPLE

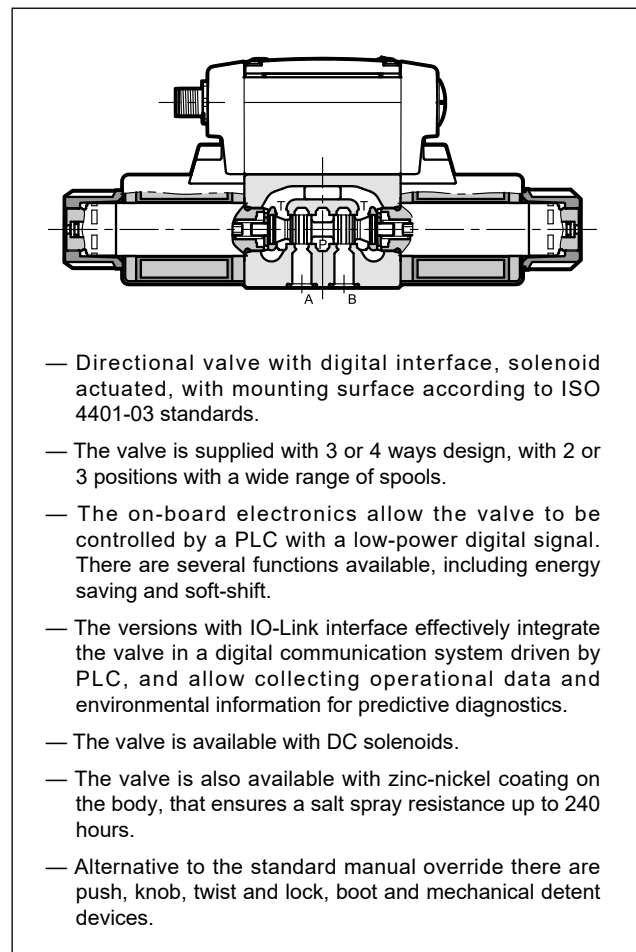

### HYDRAULIC SYMBOL (typical)

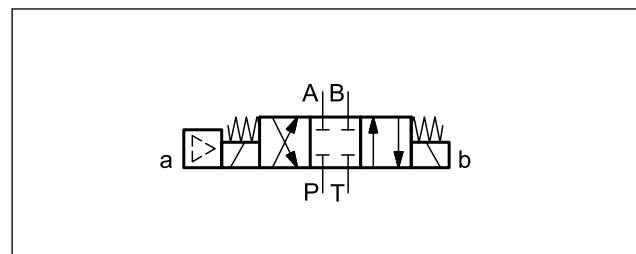

## 1 - IDENTIFICATION CODE

<b>D</b>	<b>S</b>	<b>3</b>	<b>GL</b>	<b>-</b>		<b>/ 10</b>	<b>-</b>		<b>K12</b>	<b>/</b>		
----------	----------	----------	-----------	----------	--	-------------	----------	--	------------	----------	--	--

Directional valve, solenoid operated

ISO 4401-03 size

With on-board digital amplifier

Spools types (see paragraph 3)

<b>S*</b>	<b>TA</b>	<b>RK</b>
<b>SA*</b>	<b>TB</b>	
<b>SB*</b>	<b>TA*</b>	
	<b>TB*</b>	

Spools types for ECG and IOLG versions (soft shift function):

<b>S12</b>	<b>TA12</b>
<b>S2F</b>	<b>TB12</b>
<b>S4F</b>	<b>TA23</b>
<b>S9</b>	<b>TB23</b>

Proportional spools for ECG and IOLG versions (soft-shift function)

**C26**

**A26**

Series: \_\_\_\_\_  
(the overall and mounting dimensions remain unchanged from 10 to 19)

Seals: \_\_\_\_\_  
**N** = NBR seals for mineral oil (**standard**)  
**V** = FPM seals for special fluids

**NOTE:** The standard valve is supplied with surface treatment of phosphating black.

The zinc-nickel finishing on the valve body makes the valve suitable to ensure a salt spray resistance up to **240** hours. (test operated according to UNI EN ISO 9227 standards and test evaluation operated according to UNI EN ISO 10289 standards).

Option:  
**/ W7** = Zinc-nickel surface treatment (see **NOTE**)  
Omit if not required

Manual override:  
omit for override integrated in the tube (**standard**)

- CM** = manual override, boot protected
- CP** = push manual override
- CK1** = turning knob override
- CK2** = twist and lock knob override
- CPK** = push manual override with mechanical retention

Please refer to catalogue 41150 for details on manual overrides

Connection: 5 pin M12, male

Electronic function (see paragraph 4)

- IOL** = IO-Link interface
- IOLG** = soft-shift with IO-Link interface (reserved spools only)
- ECG** = soft shift (reserved spools only)
- ECL** = power save
- EC1** = low power switch from PLC for 12V coils
- EC2** = low power switch from PLC for 24V coils

## 2 - HYDRAULIC FLUIDS

Use mineral oil-based hydraulic fluids HL or HM type, according to ISO 6743-4. For these fluids, use NBR seals (code N). For fluids HFDR type (phosphate esters) use FPM seals (code V). For the use of other fluid types such as HFA, HFB, HFC, please consult our technical department.

Using fluids at temperatures higher than 80 °C causes a faster degradation of the fluid and of the seals characteristics. The fluid must be preserved in its physical and chemical characteristics.

### 3 - SPOOL TYPE

**Type S\*:**  
2 solenoids - 3 positions  
with spring centering

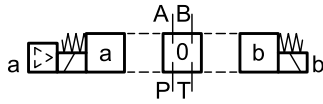

**Type SA\*:**  
1 solenoid side A  
2 positions (central + external)  
with spring centering

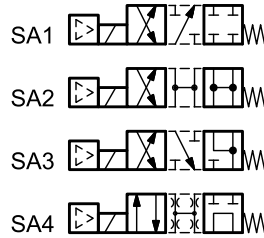
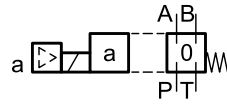

**Type SB\*:**  
1 solenoid side B  
2 positions (central + external)  
with spring centering

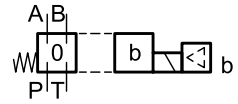

**Type TA:**  
1 solenoid side A  
2 external positions  
with return spring

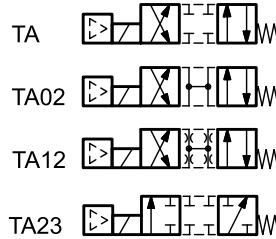
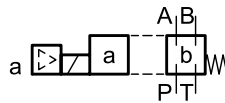

**Type TB:**  
1 solenoid side B  
2 external positions  
with return spring

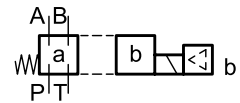

**Type RK:**  
2 solenoids - 2 positions  
with mechanical retention

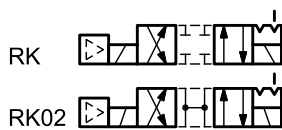
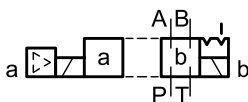

Proportional spools  
for ECG function

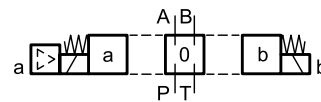

**NOTE 1:** Hydraulic symbols for S2F and S4F are identical to those of S2 and S4 spools.  
Besides the diagrams shown, which are the most frequently used, other special versions are available: please refer to catalogue 41150.

## 4 - ELECTRONICS FUNCTIONS

### 4.1 - Versions with IO-Link interface: IOL and IOLG

IOL and IOLG versions take advantages from IO-Link communication, providing different methods for feeding the power supply to the solenoid. These versions are fed 24V DC only. A data register feature is implemented for on / off time for both the solenoids, and for the up-mentioned functions.

The IOL version can operate in ECL and EC2 mode, because the function behaviour is set via bus.

The IOLG version offers the ECG type soft switching function and IO-Link interface. It is only available combined with the reserved spools (see par. 1).

### 4.2 - ECG (IOLG)

This version It is only available combined with the reserved spools. It enables hydraulic actuators to perform a smooth start and stop by setting times values (200 ÷ 600 ms) for ramp up and ramp down.

Performance limits at par. 7.

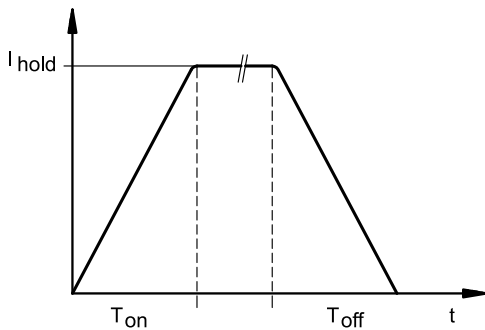

### 4.3 - ECL (IOL)

This version allows to feed the solenoid at the nominal current value for a time sufficient to guarantee the complete valve energizing (200 ms). The current is therefore automatically reduced at holding (approx 60%).

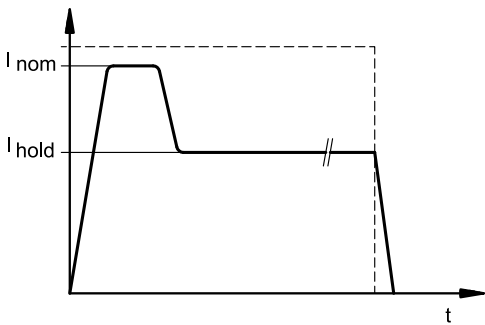

### 4.4 - EC1 / EC2 (IOL)

This version allows to control the solenoid with a low power signal coming from the PLC.

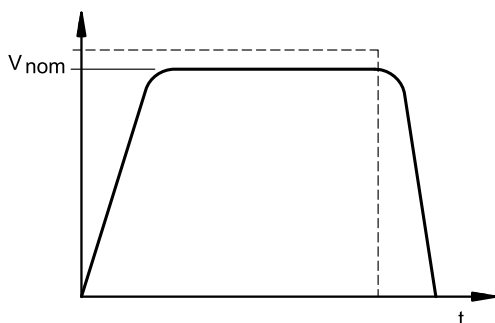



### 5 - PRESSURE DROPS $\Delta p$ -Q

(obtained with viscosity 36 cSt at 50 °C)

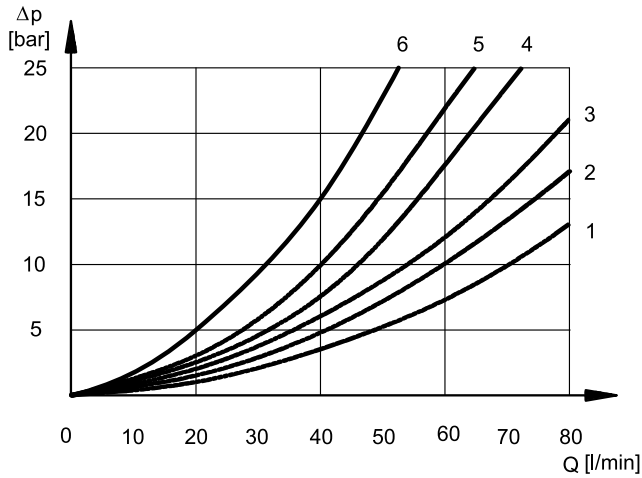

#### ENERGIZED POSITION

SPOOL TYPE	FLOW DIRECTION			
	P→A	P→B	A→T	B→T
	CURVES ON GRAPH			
S1, SA1, SB1	2	2	3	3
S2, SA2, SB2	1	1	3	3
S3, SA3, SB3	3	3	1	1
S4, SA4, SB4	5	5	5	5
S5	2	1	3	3
S6	2	2	3	1
S7, S8	4	5	5	5
S9	2	2	3	3
S10	1	3	1	3
S11	2	2	1	3
S12, S17	2	2	3	3
S18	1	2	3	3
TA, TB	3	3	3	3
TA02, TB02	2	2	2	2
TA23, TB23	3	3		
RK, RK02	2	2	2	2

For pressure drops between A and B lines of S10 spools used in regenerative diagrams, refer to curve 5.

#### DE-ENERGIZED POSITION

SPOOL TYPE	FLOW DIRECTION				
	P→A	P→B	A→T	B→T	P→T
	CURVES ON GRAPH				
S2, SA2, SB2					2
S3, SA3, SB3			3	3	
S4, SA4, SB4					3
S5		4			
S6				3	
S7, S8			6	6	3
S10	3	3			
S11			3		
S18	4				

### 6 - SWITCHING TIMES

The values indicated are obtained according to ISO 6403 standard, with mineral oil viscosity 36 cSt at 50°C.

versions	TIMES [ms]	
	ENERGIZING	DE-ENERGIZING
<b>IOL</b>	set via bus	set via bus
<b>EC*, ECL</b>	25 ÷ 75	15 ÷ 25
<b>ECG</b>	200	200

### 7 - OPERATING LIMITS

The curves define the flow rate operating fields according to the valve pressure of the different versions. The values have been obtained according to ISO 6403 norm with solenoids at rated temperature and supplied with voltage equal to 90% of the nominal voltage. The value have been obtained with mineral oil, viscosity 36 cSt, temperature 50 °C and filtration according to ISO 4406:1999 class 18/16/13.

The limits for TA02 and TA spools refer to the 4-way operation. The operating limits of a 4-way valve in 3-way operation or with port A or B plugged or without flow are shown in the related chart.

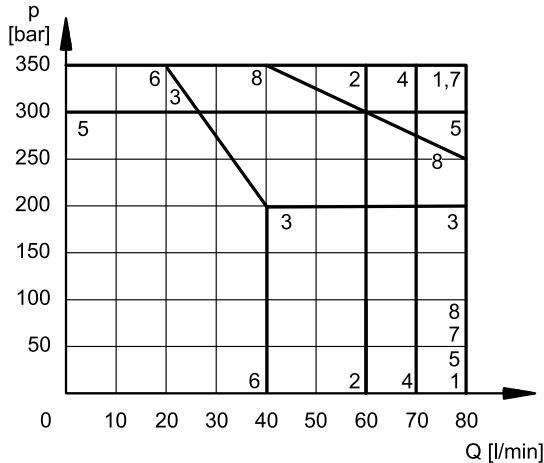

SPOOL	CURVE	
	P→A	P→B
S1, SA1, SB1	1	1
S2, SA2, SB2	2	2
S3, SA3, SB3	3	3
S4, SA4, SB4	4	4
S5	5	5
S6	4	6
S7	4	4
S8	4	4
S9	7	7
S10	7	7
S11	4	6
S12	1	1
S17	4	4
S18	5	5

SPOOL	CURVE	
	P→A	P→B
TA, TB	7	7
TA02, TB02	8	8
TA23, TB23	2	2
RK	7	7
RK02	8	8

### 4-WAY VALVE IN 3-WAY OPERATION

Operating limits of a 4-way valve in 3-way operation or with port A or B plugged or without flow.

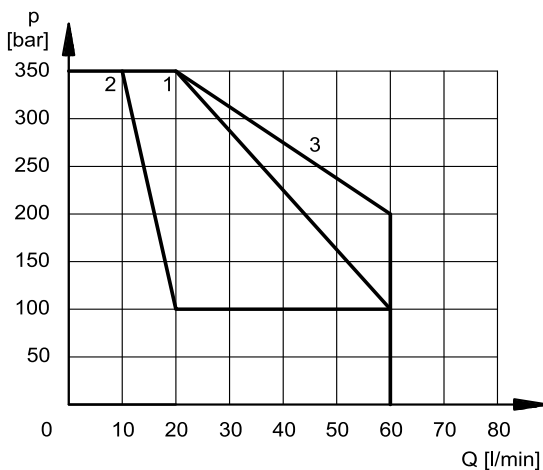

SPOOL	CURVE
TA backpr. A; TB backpr. B	1
TA02 backpr. A; TB02 backpr. B	1
TA backpr. B; B backpr. A	2
TA02 backpr. B; TB02 backpr. A	3

### SPOOLS FOR ECG AND IOLG FUNCTION

Limits of spools type S1, S12, S2F, S4F, S9, TA12, TB12, C26 and A26 specific for soft-shift valves.

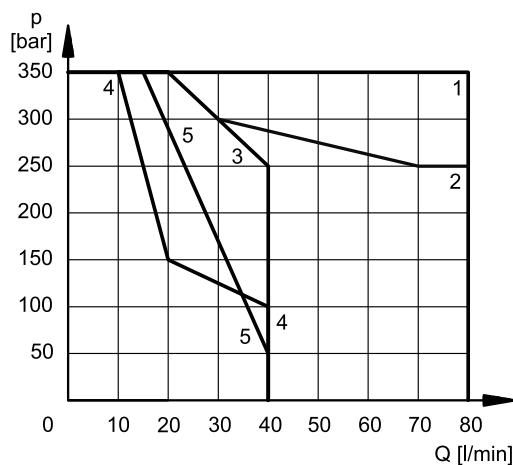

SPOOL	CURVE
S1, S12	1
S2F	2
S4F	3
S9	1
TA12, TB12	4
C26, A26	5

## 8 - ELECTRICAL FEATURES

### 8.1 - Solenoids

These are essentially made up of two parts: tube and coil. The tube is threaded into the valve body and includes the armature that moves immersed in oil, without wear. The inner part, in contact with the oil in the return line, ensures heat dissipation. The coil is fastened to the tube by a threaded ring, and can be easily replaced.

#### Protection from atmospheric agents IEC 60529

The IP protection degree is guaranteed only with both valve and connectors of an equivalent IP degree, correctly connected and installed.

electric connection	electric connection protection	whole valve protection
K6 - 2 pins for junction box	IP65	IP65

<b>SUPPLY VOLTAGE FLUCTUATION</b>	± 10% Vnom
<b>MAX SWITCH ON FREQUENCY</b>	18.000 ins/hr
<b>DUTY CYCLE</b>	100%
<b>ELECTROMAGNETIC COMPATIBILITY (EMC)</b>	In compliance with 2014/30/EU
<b>LOW VOLTAGE</b>	In compliance with 2014/35/EU
<b>CLASS OF PROTECTION</b> Coil insulation (VDE 0580) Impregnation	class H class F

### 8.2 - Current and absorbed power

The table shows current and power consumption values for each function (values ± 10%).

Function	Power supply [V]	Power consumpt [W]		Current consumpt. [A]		Coil nominal voltage [V]	Resistance at 20°C [Ω]	Coil code
		pulse	continuous	pulse	continuous			
<b>IOL</b>	24	-	24	-	1.9	12	4.5	1903800
<b>IOLG</b>	24	-	24	-	1.9	12		
<b>ECG</b>	24	-	24	-	1.9	12		
<b>ECL</b>	24	28	14	2.7	1.5	12		
<b>EC1</b>	12	-	32	-	2.67	12		
<b>EC2</b>	24	-	31	-	1.29	24	18.6	1903801

### 8.3 - IOL and IOLG functionS: IO-Link communication

2L- and 1L- are galvanic isolated up to 100 V to avoid earth loops. In IO-Link networks, the length of the connecting cables is limited to 20 metres.

Supply voltage	V DC	24 (from 19 to 30 VDC), ripple max 3 Vpp
IO-Link communication (IOL): Data rate	kBaud	IO-Link Port Class B 230,4
Managed breakdowns		Overload and electronics overheating, cable breakdown, supply voltage failures
Connection		5-pin M12 code A (IEC 61076-2-101), male

### 8.4 - IOL and IOLG pin table

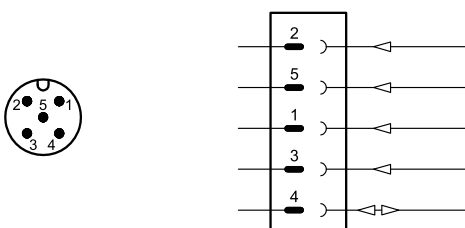

Pin	Values	Function
<b>2</b>	2L+ +24 V DC	Solenoid voltage supply
<b>5</b>	2L- 0 V (GND)	
<b>1</b>	1L+ +24 V DC	IO-Link voltage supply
<b>3</b>	1L- 0 V (GND)	
<b>4</b>	C/Q	IO-Link Communication

### 8.5 - IOL and IOLG on-board electronics diagram

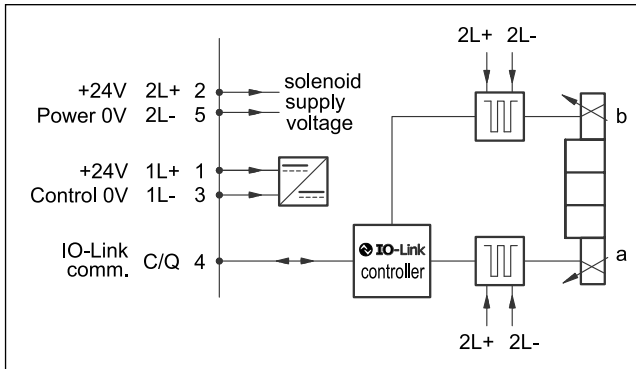

### 8.6 - IOL e IOLG functions: Led

The valve has 2 two-color LEDs visible from the top cover. They work alternatively.

led	colour	on	flashing
L1	green	-	device linked to Master
	red	device disconnected	device powered, not connected to Master
L2	green	valve ready	-
	red	error	-

### 8.7 - ECG, ECL, EC1 and EC2 functions: electrical characteristics

Supply voltage: ECG, ECL, EC2 EC1	V DC	24, ripple max 3 Vpp 12, ripple max 3 Vpp
Power consumption	W	1 + solenoid consumption (see par. 8.2)
Fuse protection, external:	A	3
Managed breakdowns		Overload and electronics overheating, supply voltage failures

### 8.8 - ECG, ECL and EC2 pin table

Pin	Values	Function
1	8 ÷ 24 V DC	Digital command coil B
2	+24 V DC	Solenoid supply voltage
3	NC	-
4	8 ÷ 24 V DC	Digital command coil A
5	0V GND	Supply voltage reference

### 8.9 - EC1 pin table

Pin	Values	Function
1	8 ÷ 12 V DC	Digital command coil B
2	+12 V DC	Solenoid supply voltage
3	NC	-
4	8 ÷ 12 V DC	Digital command coil A
5	0V GND	Supply voltage reference

### 8.10 - EC\* on-board electronics diagram

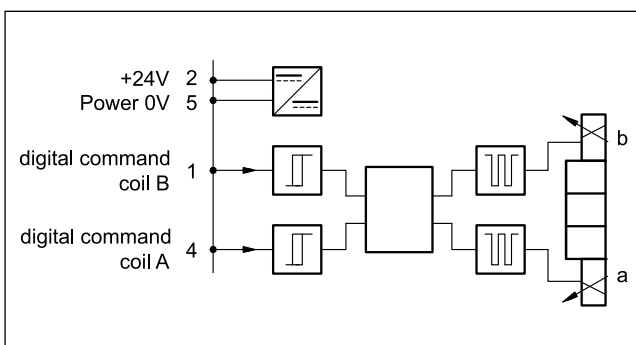

### 8.11 - EC\* fuctions: led

The valve has 2 two-color LEDs on the top cover. They work alternatively.

led	colour	on
L1	green	coil A energized
	red	coil A error
L2	green	coil B energized
	red	coil B error



## 9 - ELECTRIC CONNECTORS

A 5-poles M12 code A female connector is required. It can be ordered separately with code 3491001001. See catalogue 89 000 for details.

## 10 - OVERALL AND MOUNTING DIMENSIONS

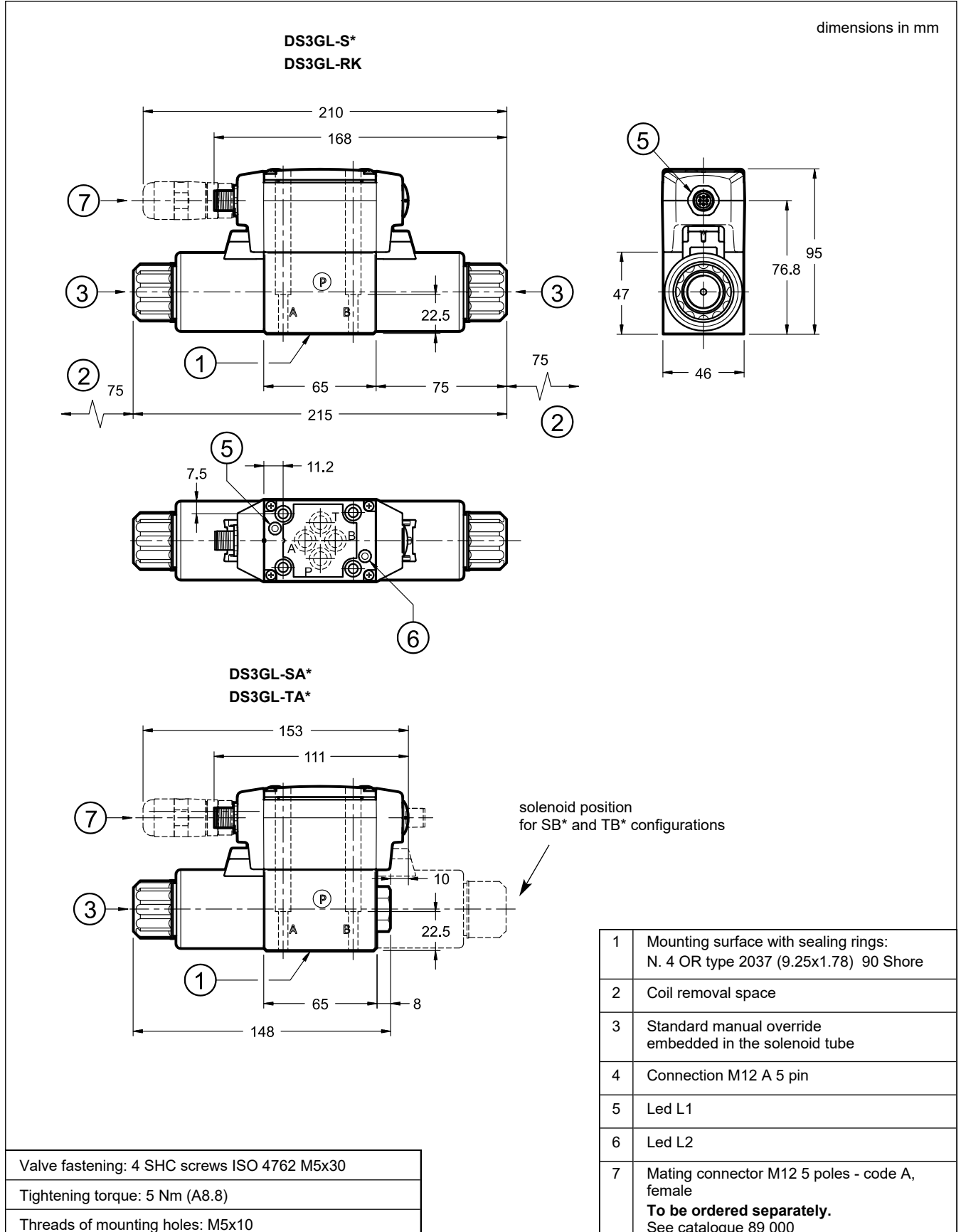



## 11 - INSTALLATION

Configurations with centering and return springs can be mounted in any position; type RK valves - without springs and with mechanical detent - must be mounted with the longitudinal axis horizontal.

Valve fixing takes place by means of screws or tie rods, with the valve mounted on a lapped surface, with values of planarity and smoothness that are equal to or better than those indicated in the drawing. If the minimum values of planarity and/or smoothness are not met, fluid leakages between valve and mounting surface can easily occur.

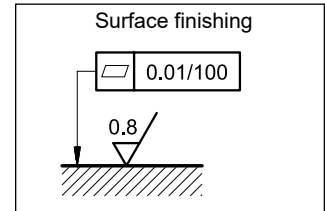

## 12 - SUBPLATES

(see catalogue 51 000)

Type PMMD-AI3G with rear ports 3/8" BSP
Type PMMD-AL3G with side ports 3/8" BSP