

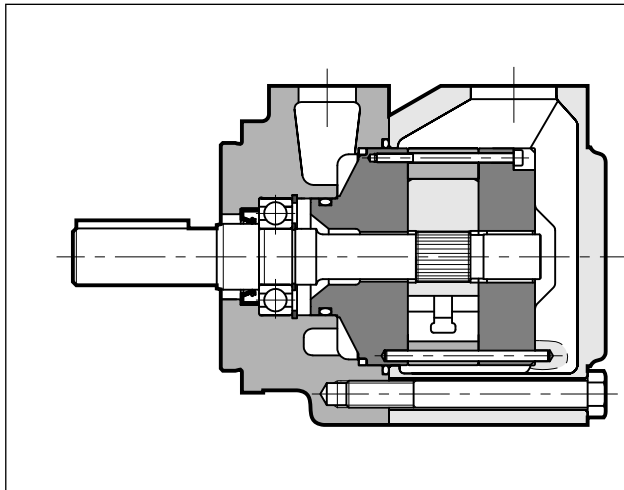

DFP

FIXED DISPLACEMENT VANE PUMPS SERIES 20

OPERATING PRINCIPLE



- The DFP pumps are fixed displacement vane pumps available in four sizes, each size having five nominal displacement. They are available with one pumping element (single pump) or with two pumping element (double pump).
- The pumping group consists of a compact cartridge that contains the rotor, the vanes, the cam ring and the head discs. The cartridge is easily removable without the need to disconnect the pump from the hydraulic circuit, thus simplifying the maintenance operations.
- The special elliptical profile of the cam ring with double opposing suction and delivery chambers eliminates the radial thrusts on the rotor, significantly reducing pump wear. The use of a 12-vane rotor reduces the pulsations in the delivery, limiting the vibrations and noise level of the pump.

TECHNICAL SPECIFICATIONS

PUMP SIZE		1	2	3	4
Displacement range	cm ³ /rev	18 ÷ 45,9	40,1 ÷ 67,5	69 ÷ 121,6	138,6 ÷ 193,4
Flow rate range (at 1500 rpm)	l/min	26,1 ÷ 69,6	101,4 ÷ 177,3	49,6 ÷ 97,3	203,4 ÷ 285
Operating pressures	bar	140 ÷ 210	175	175	175
Rotation speed	rpm	600 ÷ 1800			
Rotation direction		clockwise or counterclockwise			
Loads on the shaft		axial loads are not allowed			
Hydraulic connections		SAE J518 c fittings, flanged (see par. 9)			
Mounting flange type		SAE J744			
Mass (single pump)	kg	12	15	23	34

Ambient temperature range	°C	-20 / +50
Fluid temperature range	°C	-10 / +70
Fluid viscosity range		see point 4.2
Degree of fluid contamination		see point 4.3
Recommended viscosity	cSt	13 ÷ 54

HYDRAULIC SYMBOL

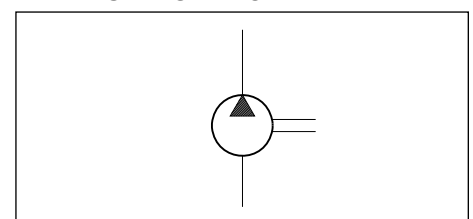

2 - PORT POSITIONS

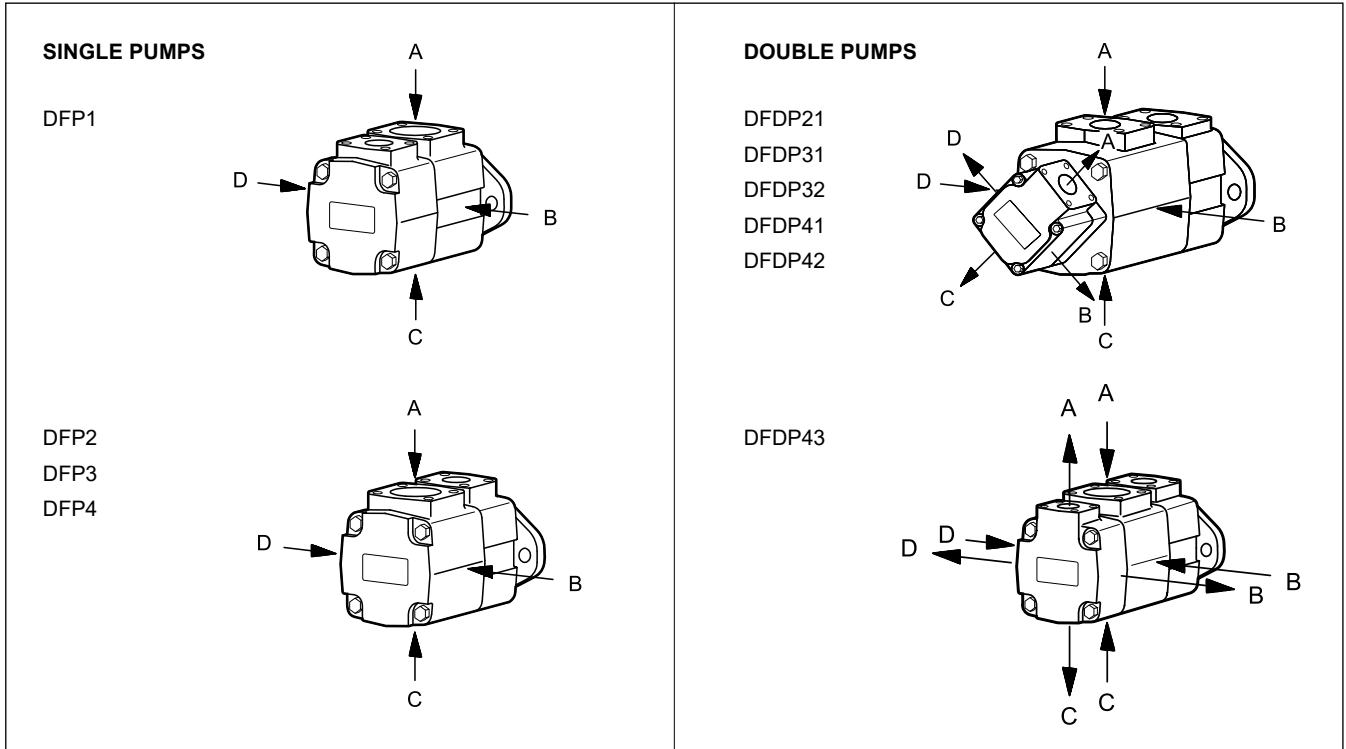

3 - PERFORMANCES

(obtained with mineral oil with viscosity 25 cSt at 45 °C)

PUMP SIZE	NOMINAL DIMENSION	GEOMETRIC DISPLACEMENT [cm ³ /giro]	NOMINAL FLOW RATE. (at 1500 rpm) [l/min]	MAX PRESSURE (NOTE) [bar]	ROTATION SPEED (see also point 5) [rpm]	
					max	min
DPF1	05	18	26.1	210	1800	600
	08	27.4	39.4			
	11	36.4	52.6			
	12	39.5	58.7	160		
	14	45.9	69.6	140		
DFP2	12	40.1	58.8	175	1800	600
	14	45.4	65.7			
	17	55.2	80.2			
	19	60.1	88.7			
	21	67.5	99.8			
DFP3	21	69	101.4	175	1800	600
	25	81.6	120.1			
	30	97.7	121.4			
	35	112.7	167.2			
	38	121.6	177.3			
DFP4	42	138.6	203.4	175	1800	600
	47	153.5	222.7			
	50	162.2	234			
	57	183.4	267			
	60	193.4	185			

NOTE: A pressure peak of + 10% is allowed for a time not exceeding 0.5 seconds, if temperature and filtration conditions are optimal)

4 - HYDRAULIC FLUID

4.1 - Fluid type

The maximum suction pressure allowed, with all fluid types, is 1,4 bar. The minimum suction pressure varies from -0,17 bar with mineral oil to -0,1 bar with other fluid types (the pressure values are to be considered relative)..

Pressures, maximum allowed speeds and recommended temperatures are shown in the table according to the hydraulic fluids types.

FLUID TYPES	p max [bar]	max speed [rpm]	working temperature [°C]
HFC (NOTE 1) (water-glycol solutions)	160 (NOTE 2)	1500	+15 / +50

NOTE 1: Water-glycol solutions are not compatible with Viton seals. The pumps are tested with mineral oil. Provide an adequate cleaning cycle.

NOTE 2: The max allowed pressure is 140 bar for DFP1-14.

4.2 - Fluid viscosity

The operating fluid viscosity must be within the following range:

minimum viscosity	13 cSt	referred to the maximum temperature of 70 °C of the fluid
optimum viscosity	13 ÷ 54 cSt	referred to the operating temperature of the fluid in the tank +30 / +60 °C
maximum viscosity	860 cSt	limited to only the pump start-up phase

When choosing the fluid type, verify that the true viscosity at the operating temperature is within the above range.

4.3 - Degree of fluid contamination

The maximum degree of fluid contamination must be according to ISO 4406:1999 class 20/18/15; therefore, use of a filter with $\beta_{20} \geq 75$ is recommended. A degree of maximum fluid contamination according to ISO 4406:1999 class 18/16/13 is recommended for optimum endurance of the pump. Hence, use of a filter with $\beta_{10} \geq 100$ is recommended.

If there is a filter installed on the suction line, be sure that the pressure at the pump inlet is not lower than the values specified at point 4.1. The suction filter must be equipped with a by-pass valve and, if possible, with a clogging indicator.

5 - MAXIMUM SPEED CORRECTION FACTOR

If the pressure in the suction line is different than zero, the maximum rotation speed shown in table 3 must be multiplied by the correction factor obtained from the diagram here below.

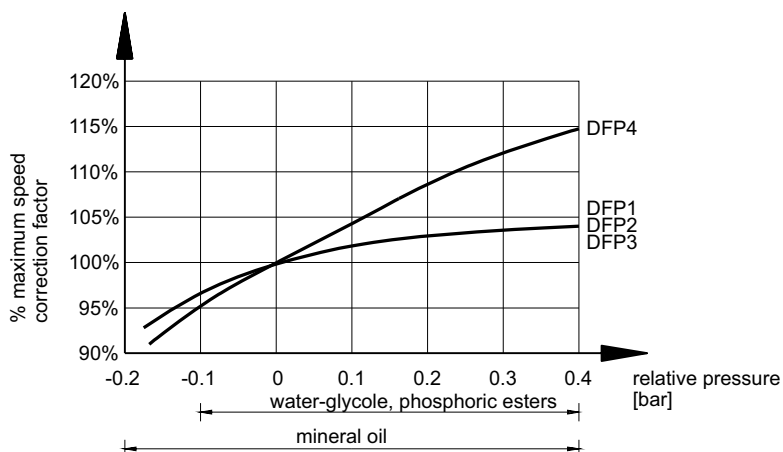

6 - NOISE LEVEL

(values obtained with mineral oil with viscosity of 25 cSt at 40°C, delivery pressure 140 bar and suction pressure 0 bar)

The diagram curves were measured in a semi-anechoic room, at a distance of 1 m from the pump. The shown values must be reduced by 5 dB(A) if they are to be considered in a completely anechoic room.

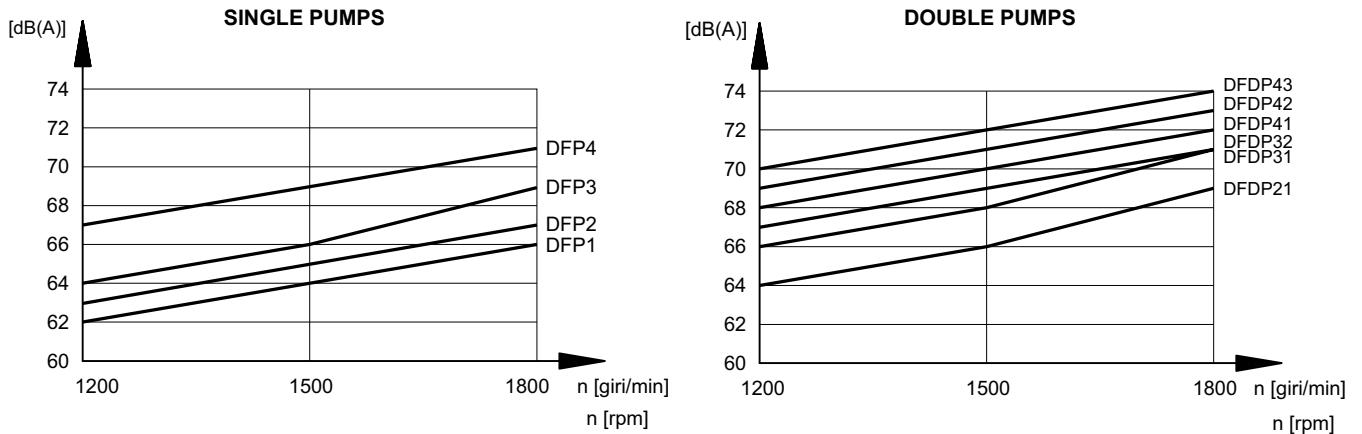

7 - CHARACTERISTIC CURVES

(obtained with mineral oil with viscosity of 25 cSt at 45 °C and 1500 rpm speed)

7.1 - DFP1 pumps

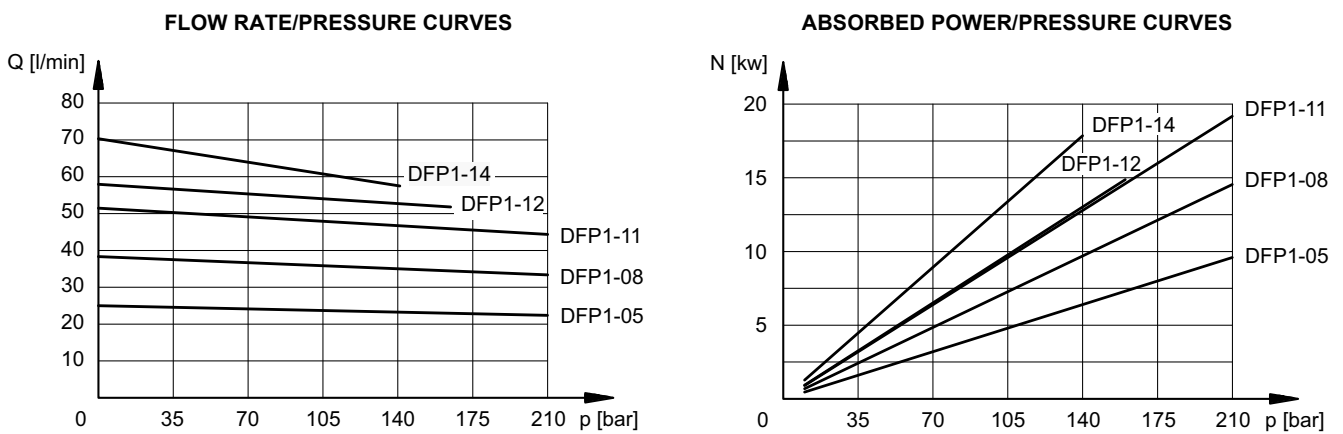

7.2 - DFP2 pumps

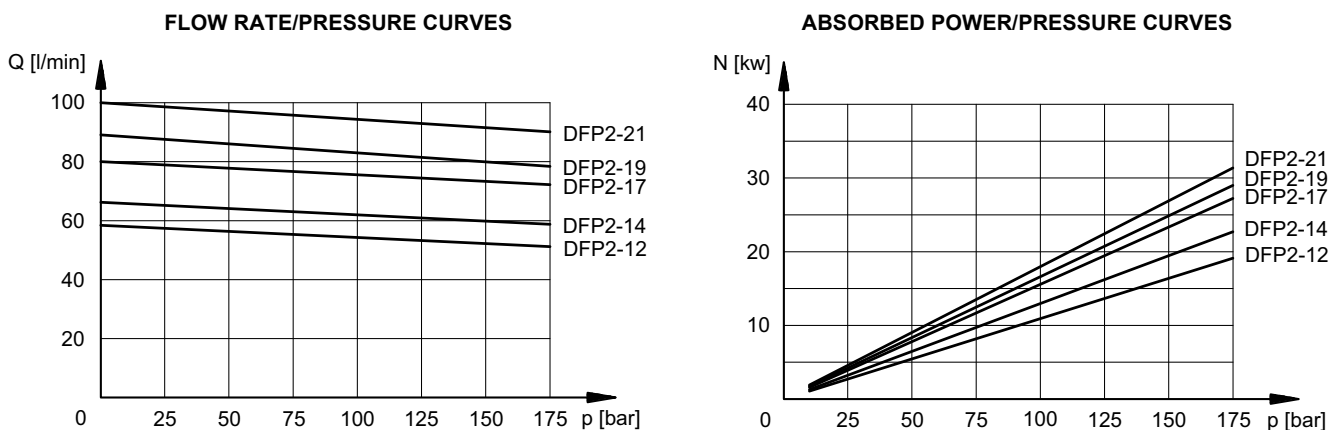



7.3 - DFP3 pumps

FLOW RATE/PRESSURE CURVES

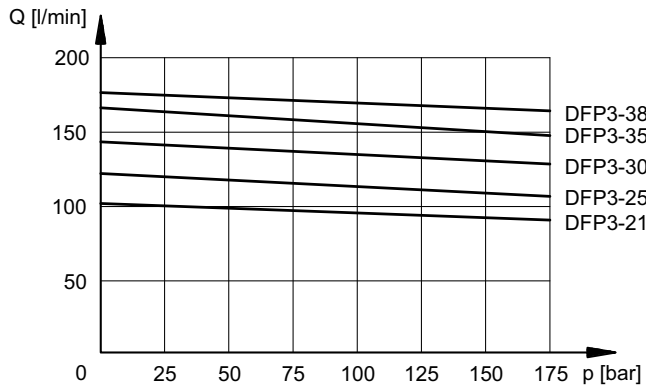

ABSORBED POWER/PRESSURE CURVES

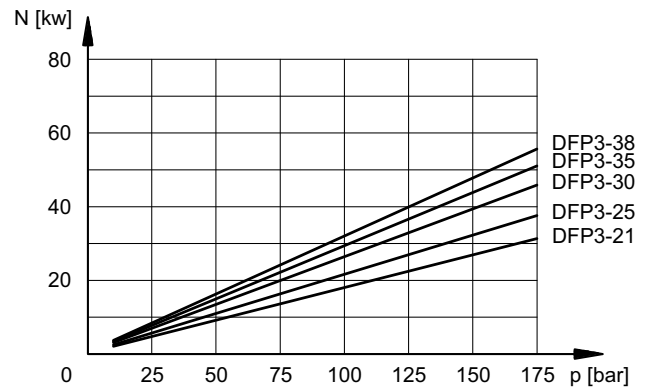

7.4 - DFP4 pumps

FLOW RATE/PRESSURE CURVES

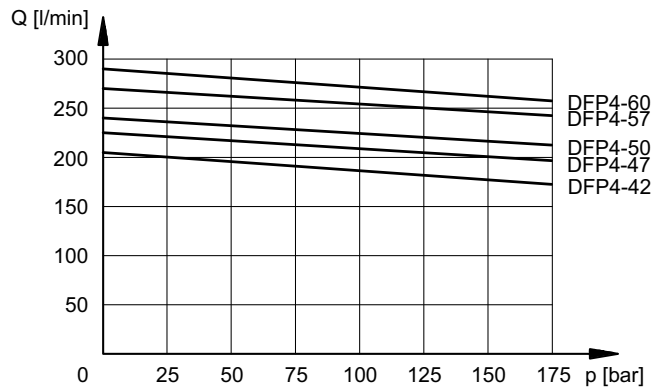

ABSORBED POWER/PRESSURE CURVES

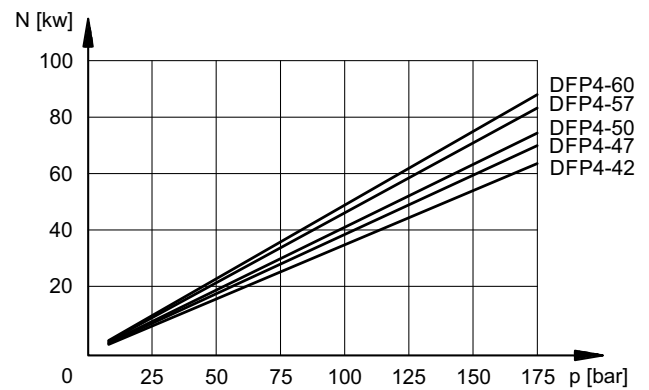

8 - DFP1 PUMP OVERALL AND MOUNTING DIMENSIONS

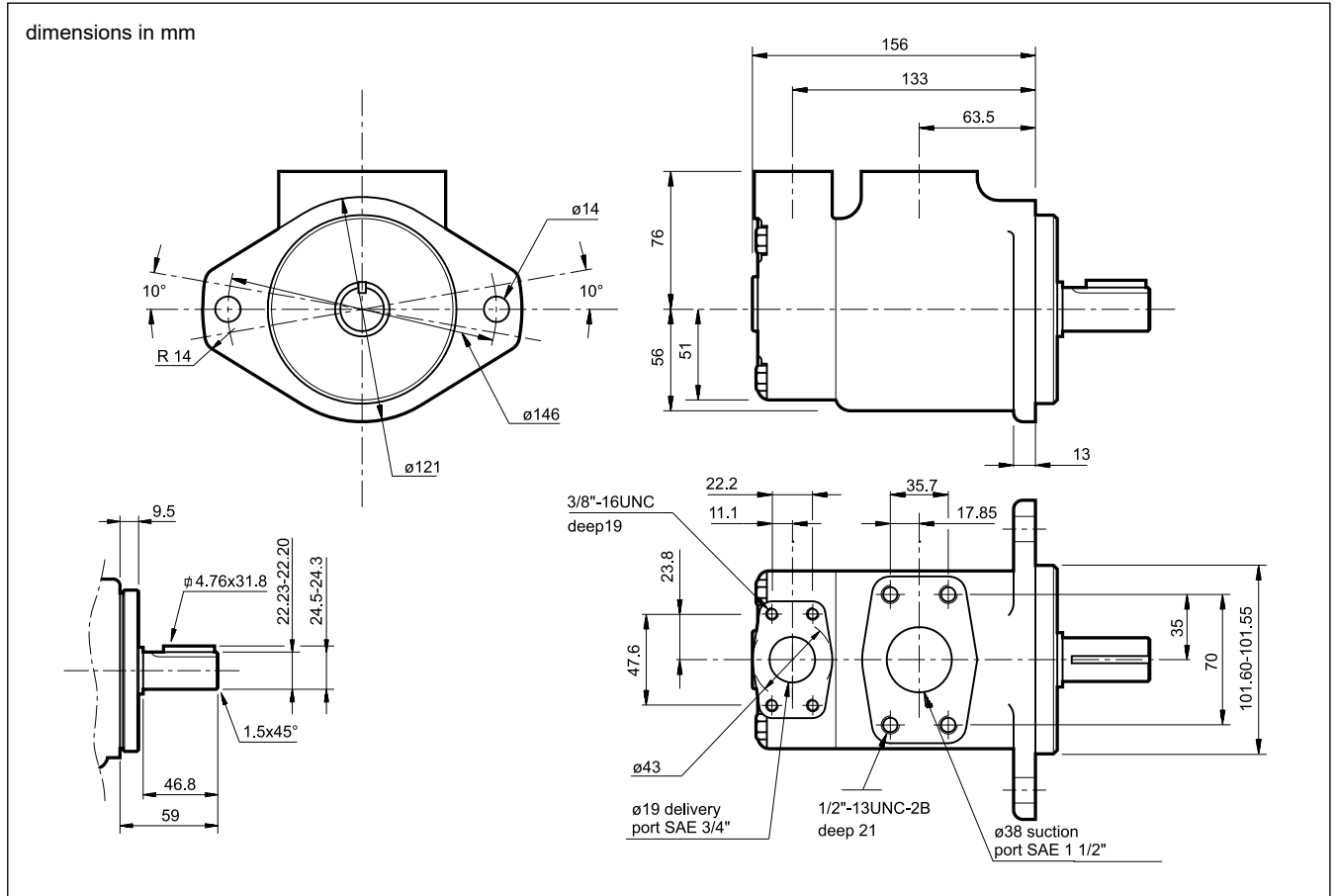

9 - DFP2 PUMP OVERALL AND MOUNTING DIMENSIONS

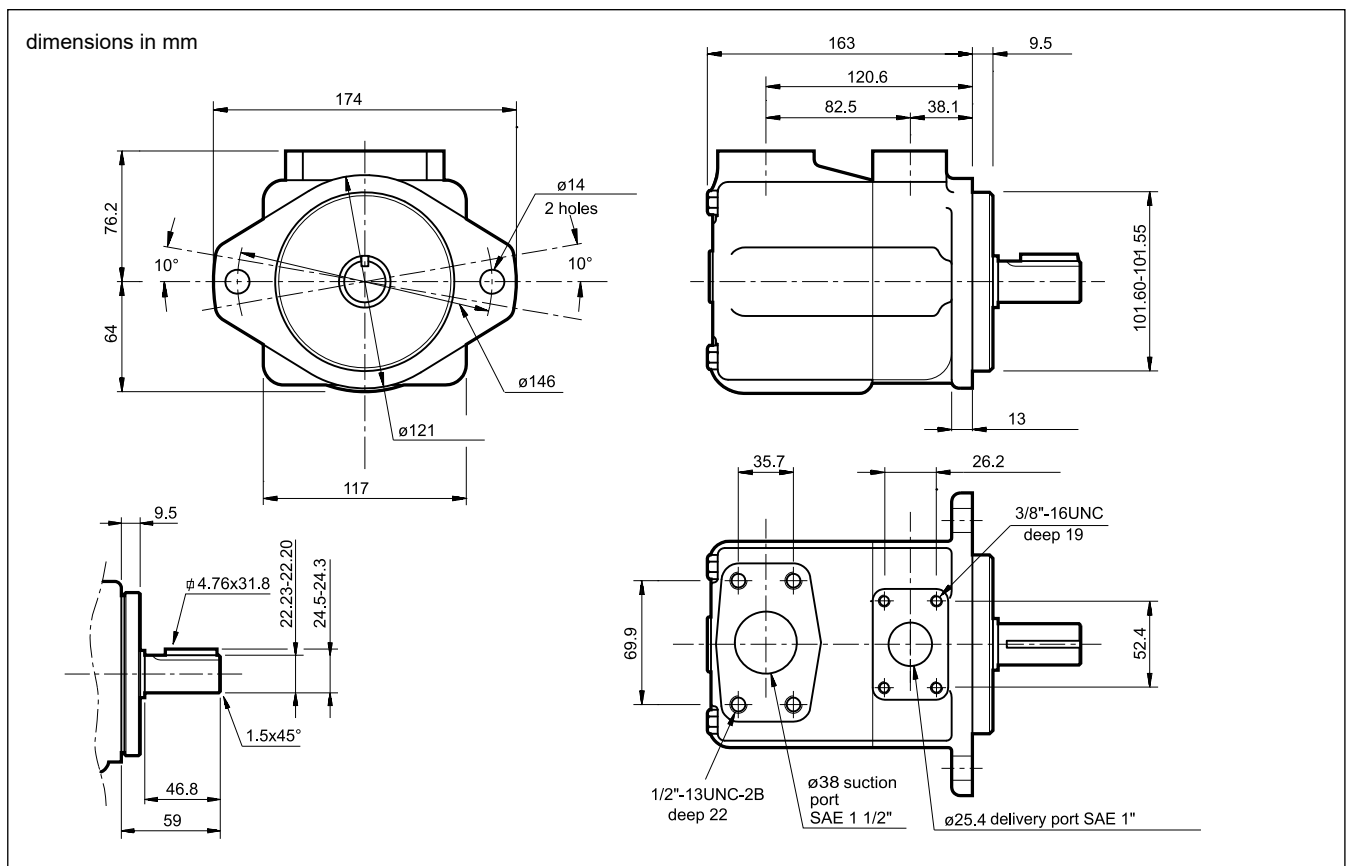

10 - DFP3 PUMP OVERALL AND MOUNTING DIMENSIONS

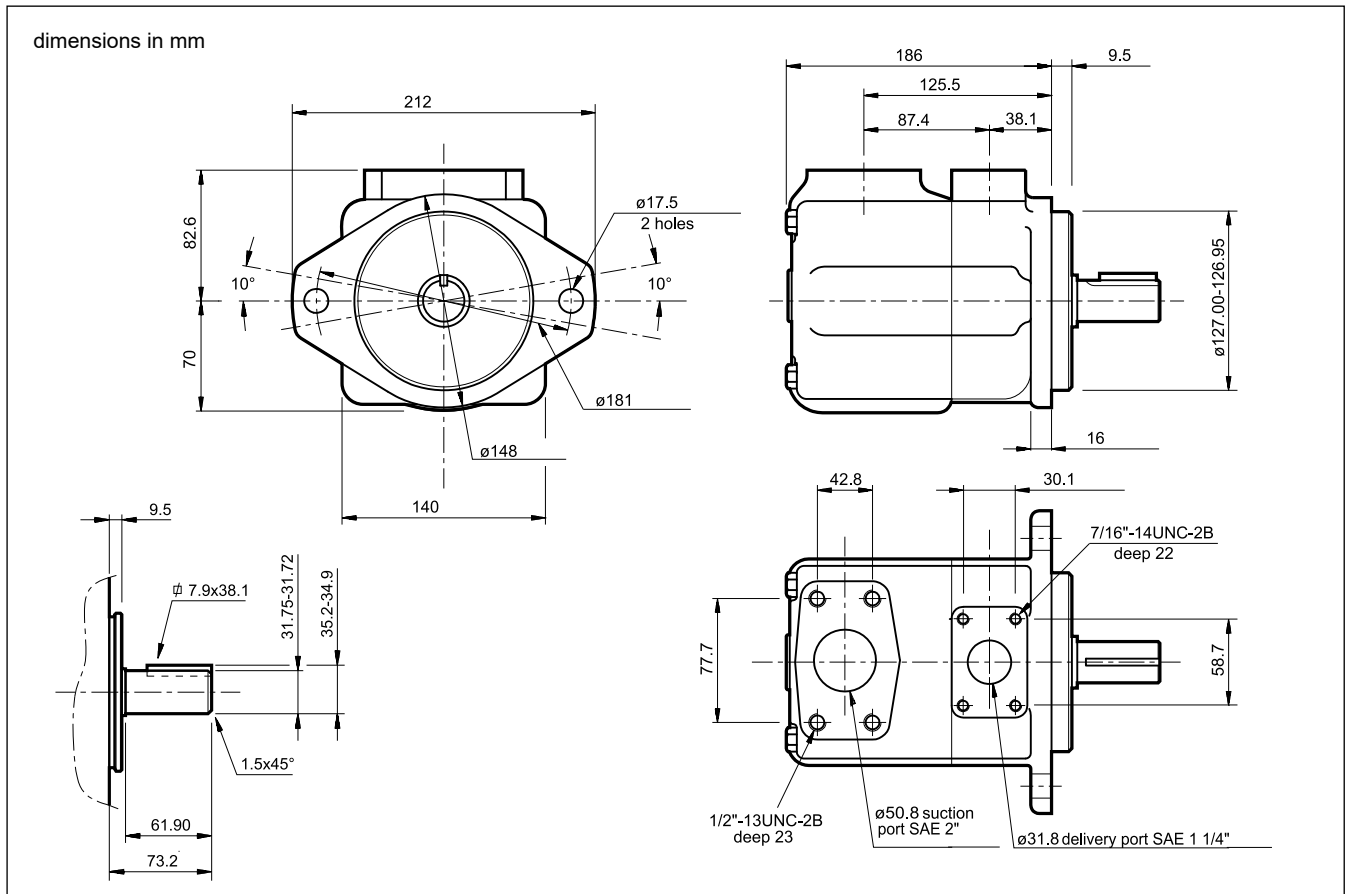

11 - DFP4 PUMP OVERALL AND MOUNTING DIMENSIONS

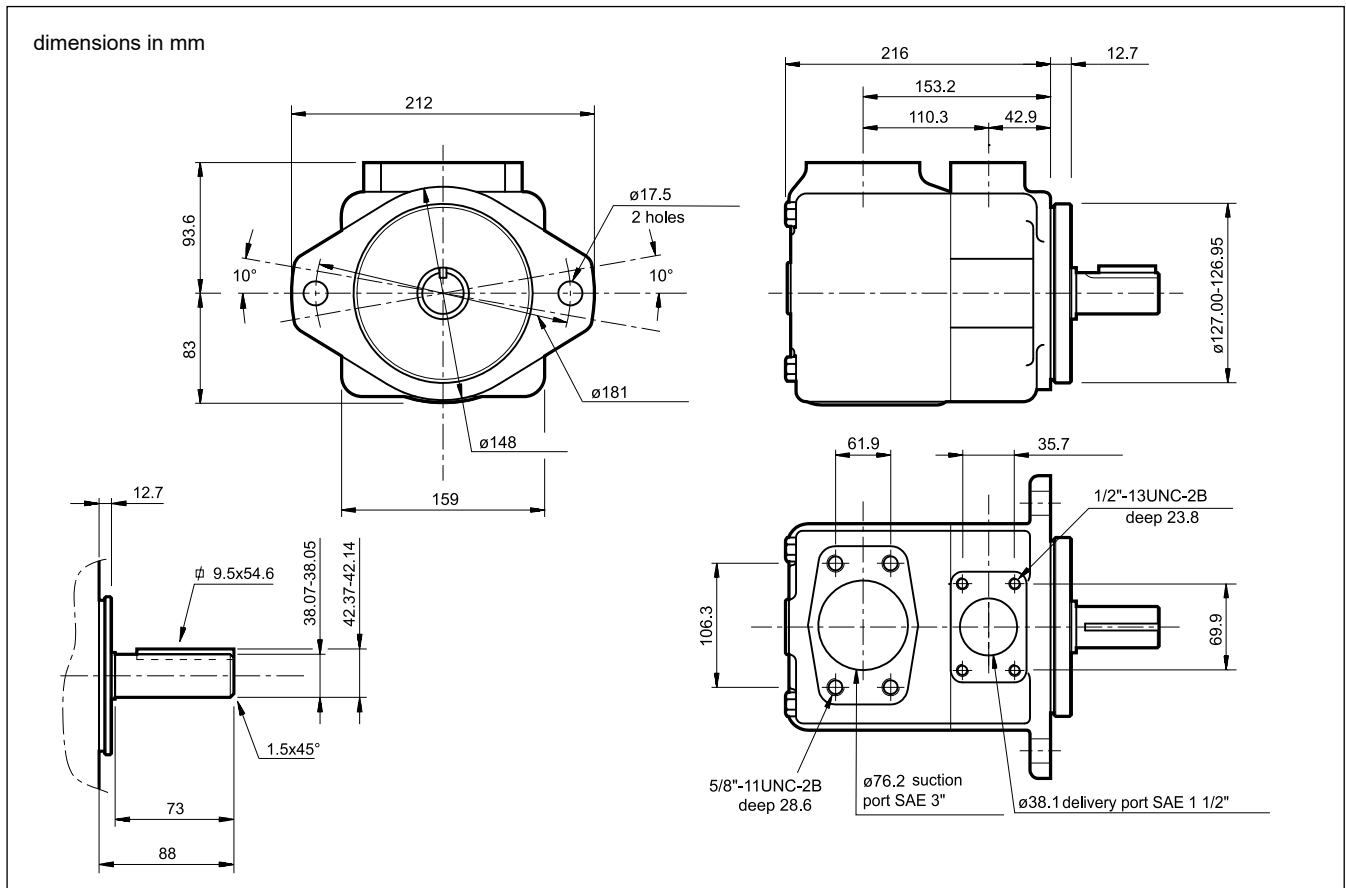

12 - DFDP21 DOUBLE PUMP OVERALL AND MOUNTING DIMENSIONS

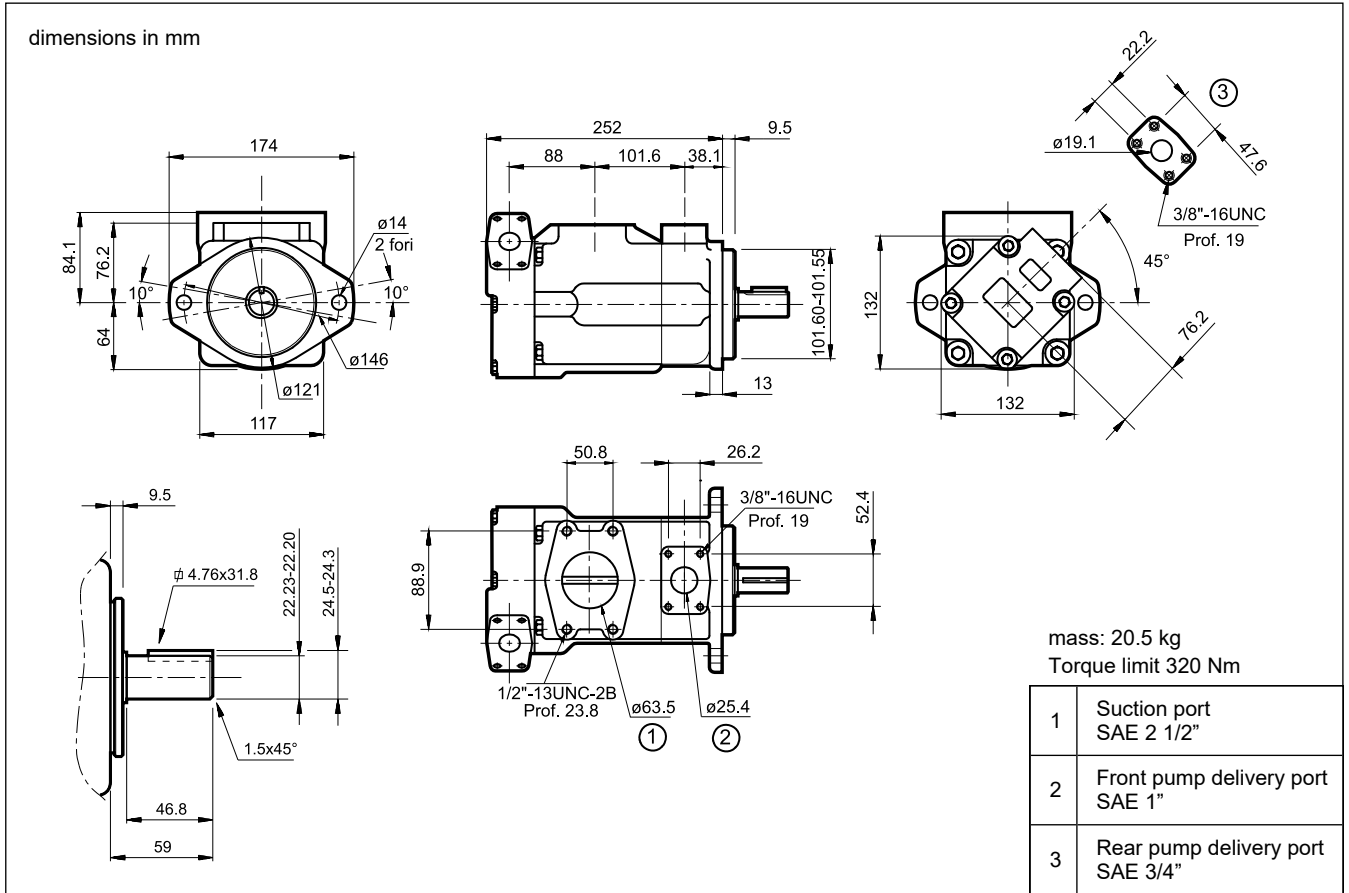

13 - DFDP31 DOUBLE PUMP OVERALL AND MOUNTING DIMENSIONS

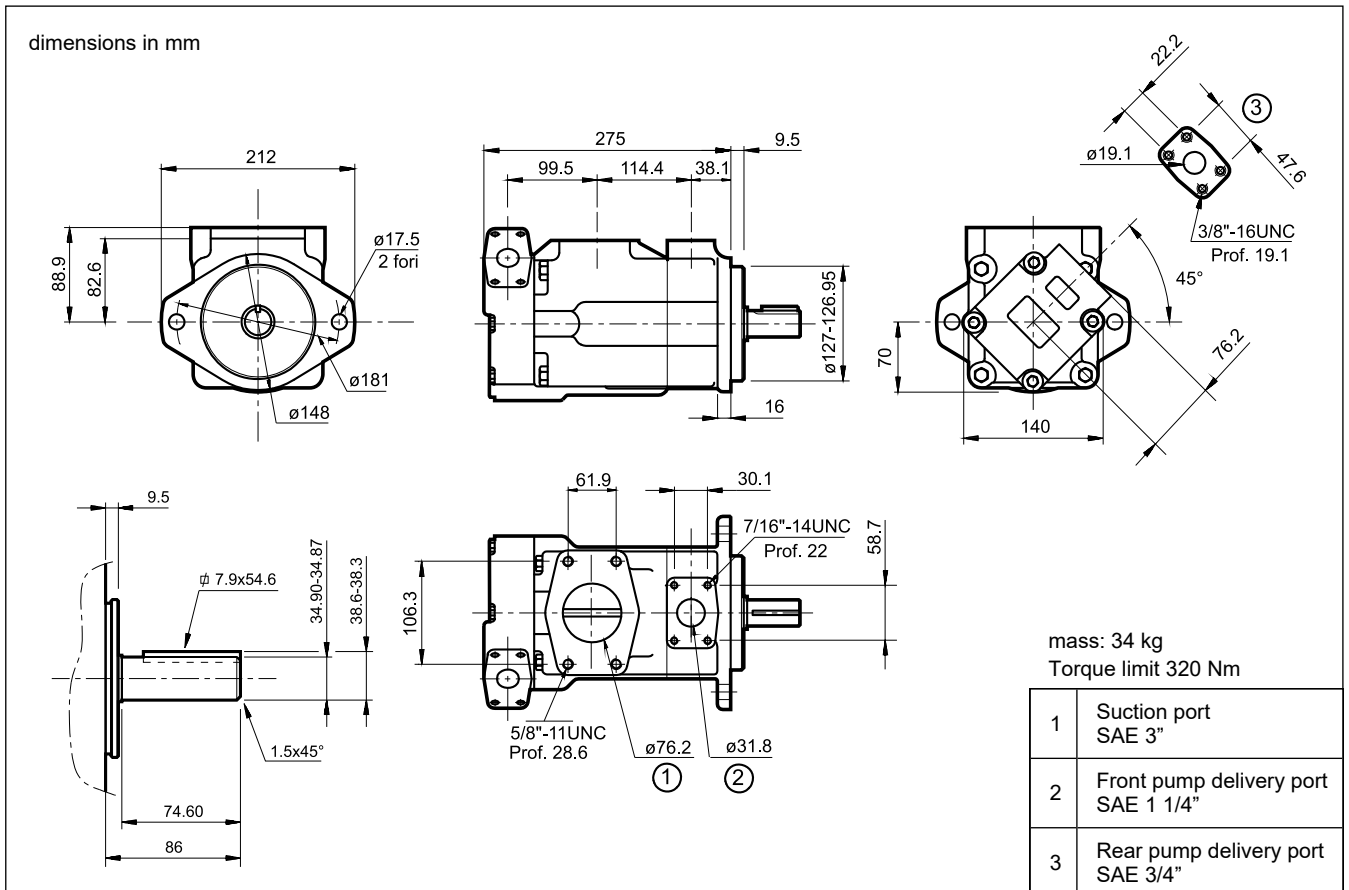

14 - DFDP32 DOUBLE PUMP OVERALL AND MOUNTING DIMENSIONS

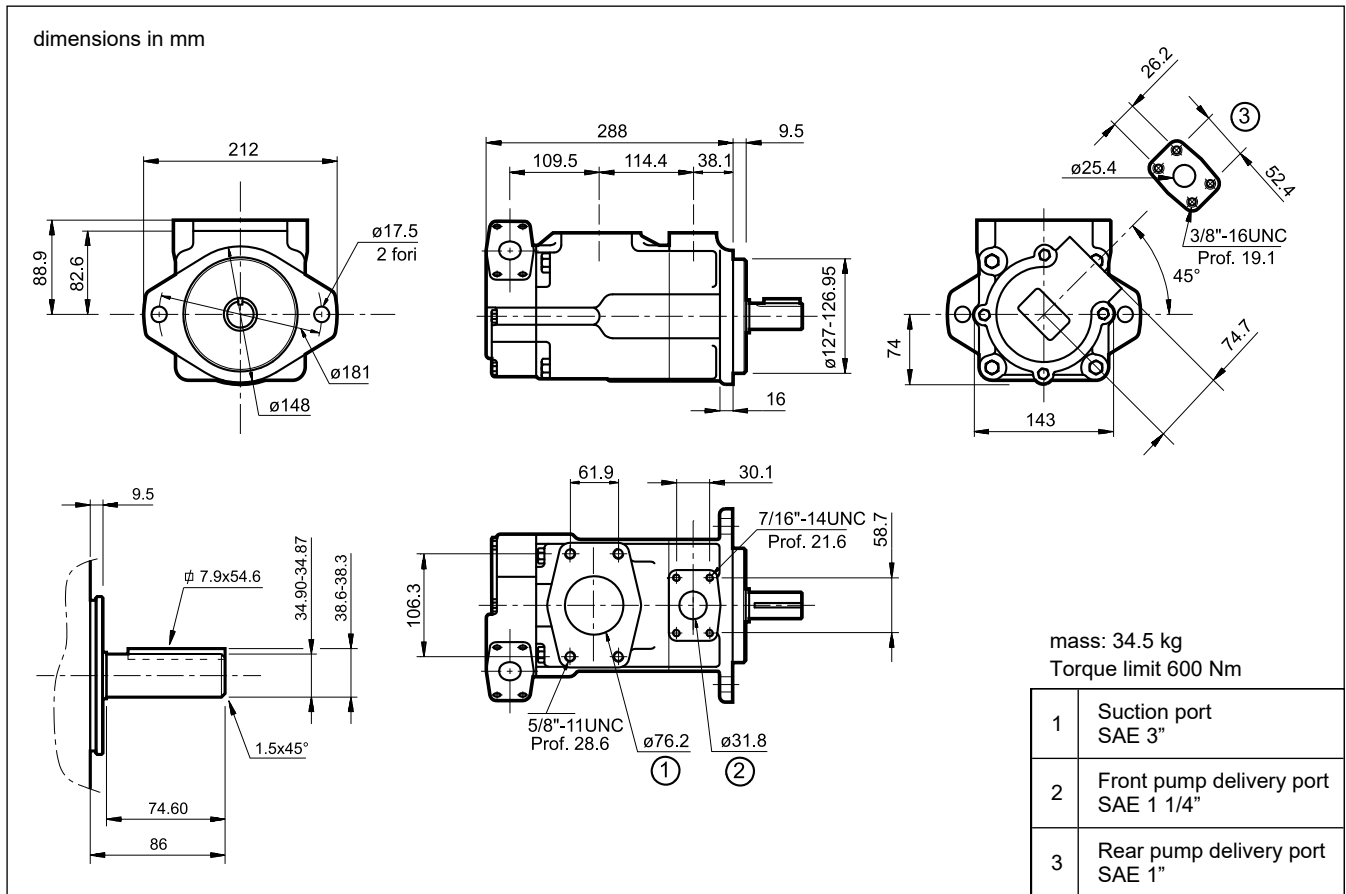

15 - DFDP41 DOUBLE PUMP OVERALL AND MOUNTING DIMENSIONS

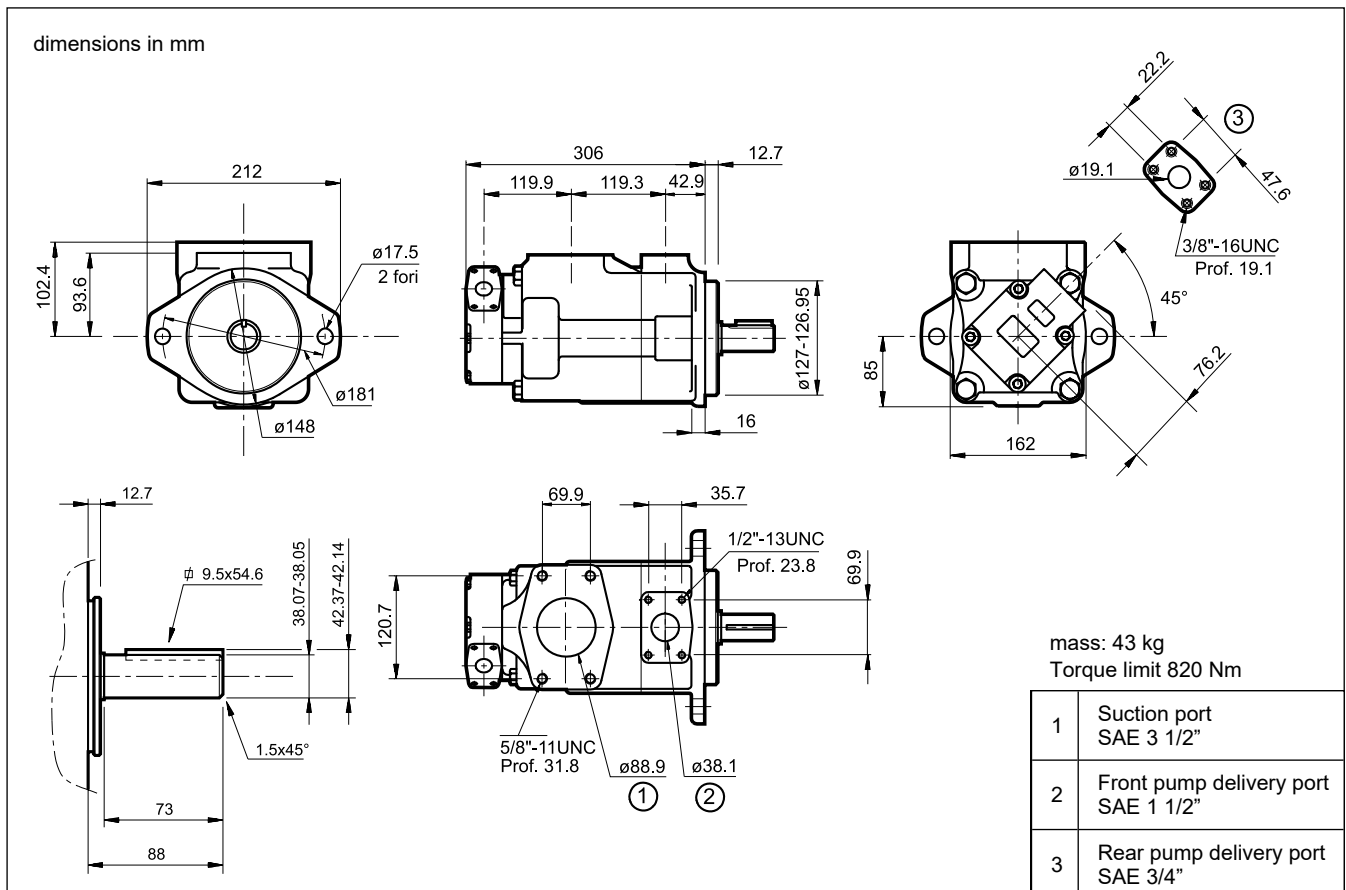

16 - DFDP42 DOUBLE PUMP OVERALL AND MOUNTING DIMENSIONS

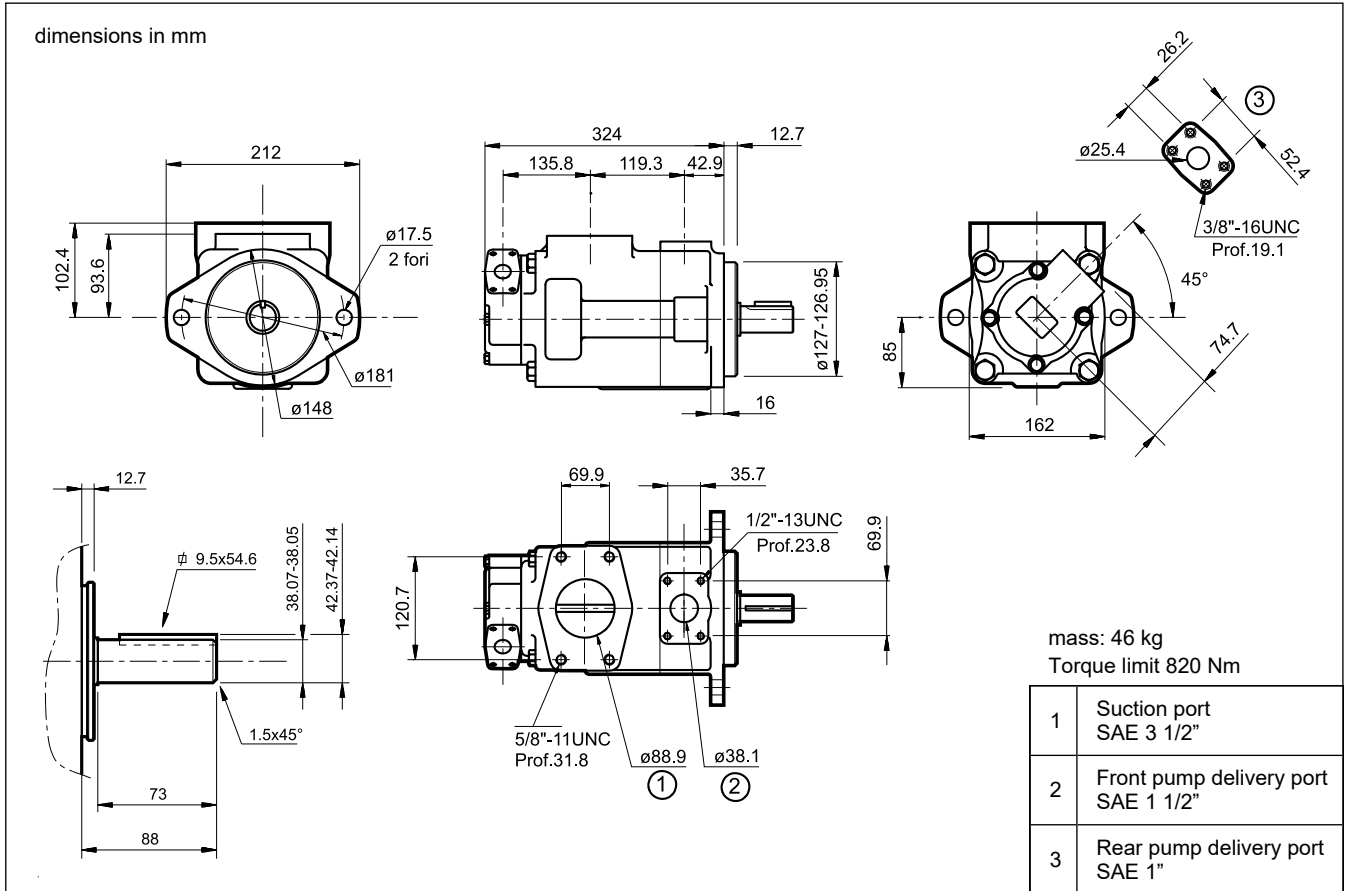

17 - DFDP43 DOUBLE PUMP OVERALL AND MOUNTING DIMENSIONS

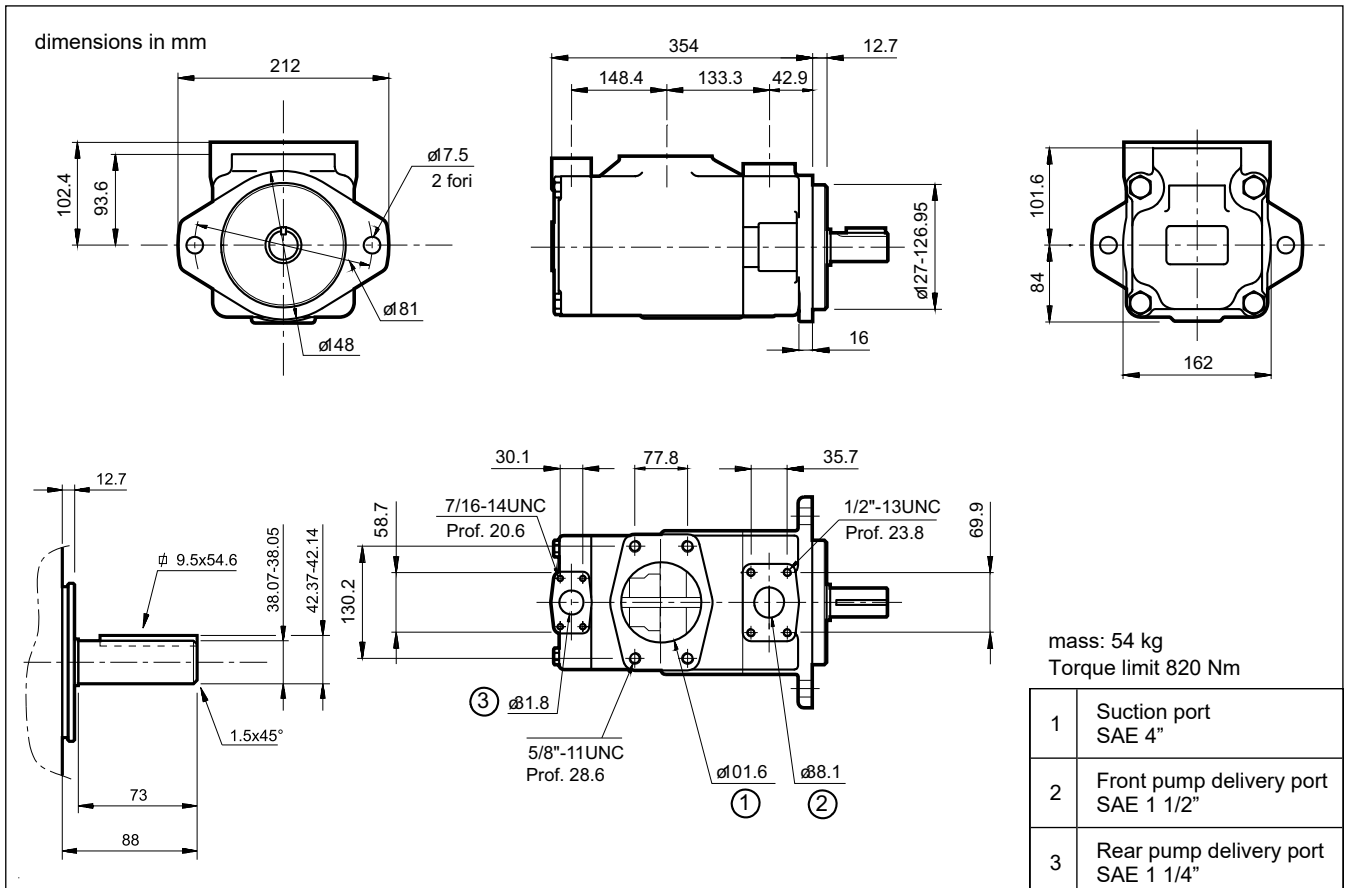

18 - INSTALLATION

The DFP pumps can be installed in any position.

Before starting, check that the direction of rotation of the motor agrees with the direction of rotation of the pump .

The pump start up, especially at a cold temperature, should occur with the pump unloading.

The suction pipe must be suitably sized to facilitate the flow of oil. Any of bends and bottlenecks or an excessive length of the suction line can impair the correct operation of the pump.

It is good to place the pump under the tank. Otherwise, make sure that the minimum level of the fluid is higher than the level of the pump suction line to avoid drain from the suction line with the pump at standstill. In the case of circuits with high flow rate and pressure values, it is advisable to install the pump under the head.

The motor-pump coupling must be made directly with a flexible coupling. Couplings that generate axial or radial loads on the pump shaft are not allowed.

Refer to point 4.3 for the characteristics and installation of the filtering elements.

The pump body and the suction line must be filled with fluid before starting the engine. The pump start-up must take place with minimum pressure in the system especially at low temperatures.

Start the engine several times for about 1 second, at regular intervals of 2-3 seconds, until the pump has been primed. Check with a pressure gauge that the delivery pressure increases slightly. Operate all the system components several times until the air bubbles disappear in the fluid returning to the tank. Only after that, gradually increase the pressure.

19 - SAE J518 CONNECTION FLANGES

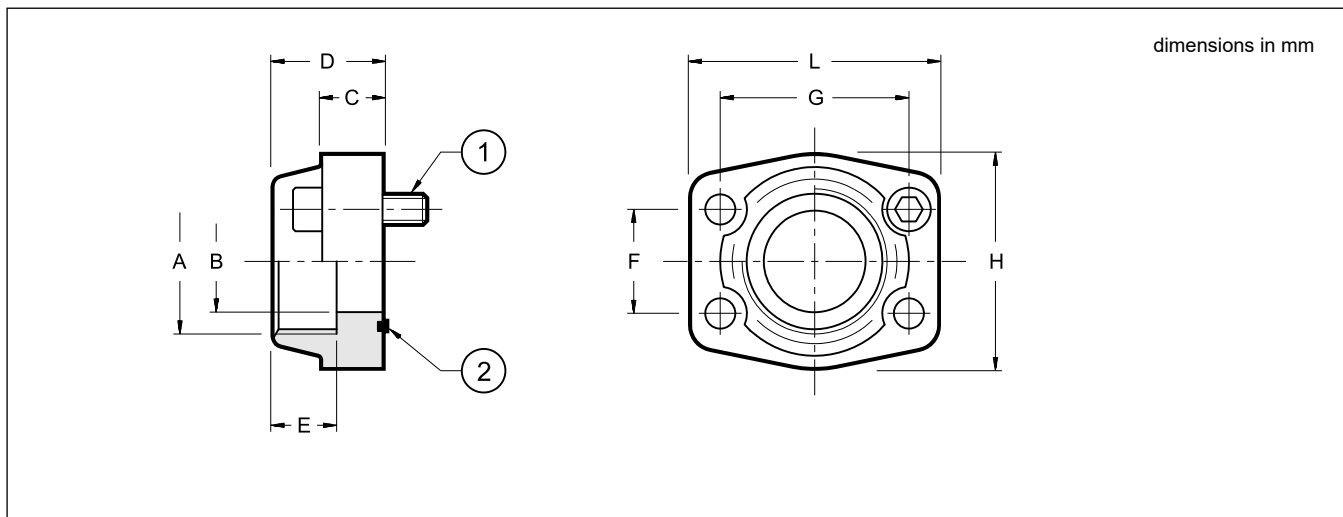

NOTE: The fastening bolts and the O-Rings must be ordered separately.

Flange code	Flange description	P _{max} [bar]	ØA	ØB	C	D	E	F	G	H	L	1 N. 4 SHC bolts	Bolts code	2
0610719	SAE - 3/4"	345	3/4" BSP	19	18	36	19	22,2	47,6	50	65	3/8" UNC x 1 1/2"	0530612	OR 4100
0610713	SAE - 1"	345	1" BSP	25	18	38	22	26,2	52,4	55	70			OR 4131
0610720	SAE - 1 1/4"	276	1 1/4" BSP	32	21	41	22	30,2	58,7	68	79	7/16" UNC x 1 1/2"	0530613	OR 4150
0610714	SAE - 1 1/2"	207	1 1/2" BSP	38	25	45	24	35,7	70	78	93	1/2" UNC x 1 3/4"	0530638	OR 4187
0610721	SAE - 2"	207	2" BSP	51	25	45	30	43	77,8	90	102			OR 4225
0610722	SAE - 2 1/2"	172	2 1/2" BSP	63	25	50	30	50,8	89	105	116			OR 4175
0610723	SAE - 3"	138	3" BSP	73	27	50	34	62	106,4	116	134	5/8" UNC x 2"	0530658	OR 4337
0610724	SAE - 3 1/2"	34	3 1/2" BSP	89	27	48	34	69,8	120,7	136	152			OR 4387
0773528	SAE - 4"	34	4" BSP	99	27	48	34	77,77	130,18	146	162			OR 4437