

FV7*S

FIXED DISPLACEMENT VANE PUMPS SERIES 10

OPERATING PRINCIPLE

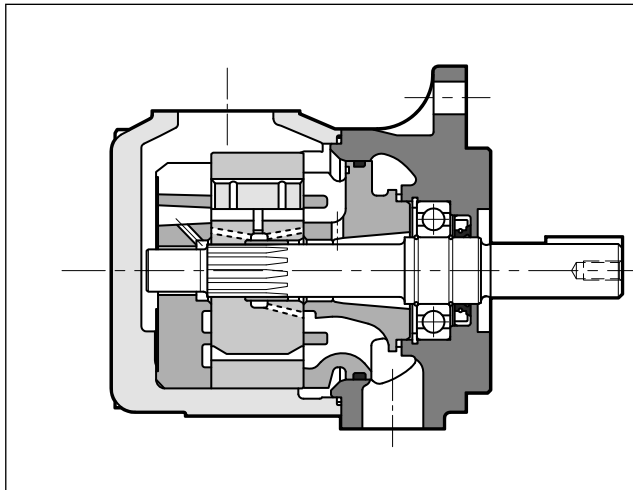

- The FV7*S pumps are fixed displacement vane pumps, with several nominal displacement each. Single, double and triple pumps are available.
- The pumping group is composed of a cartridge element that contains rotor, vanes, cam ring and support plates. Cartridges are easily removable without disconnecting the pump from the hydraulic circuit, thus simplify the maintenance operations.
- The special elliptical profile of the cam ring, with double suction and delivery chambers one against the other, eliminates the radial thrusts on the rotor, reducing wear of the pump. The use of a 12 vane rotor reduces the delivery pressure pulsations, suppressing the vibrations and noise level of the pump.

TECHNICAL SPECIFICATIONS

PUMP SIZE (SINGLE)		FV7BS	FV7DS
Displacement range	cm ³ /rev	5.8 ÷ 50	44 ÷ 137.5
Flow rate range (at 1500 rpm - 0 bar)	l/min	8.7 ÷ 75	66 ÷ 206
Operating pressure	bar	320	250
Rotation speed (max)	rpm	3600	3000
Rotation direction		clockwise or anticlockwise	
Loads on shaft		see diagrams	
Hydraulic connections		SAE J518	SAE J518
Mounting flange		SAE B J744	SAE C J744
Mass (empty single pump)	kg	23	26

Ambient temperature range	°C	-20 / +60
Fluid temperature range (see par. 4)	°C	-10 / +70
Fluid viscosity range	cSt	see paragraph 4
Fluid contamination degree	see paragraph 4.3	
Recommended viscosity	cSt	30

HYDRAULIC SYMBOLS

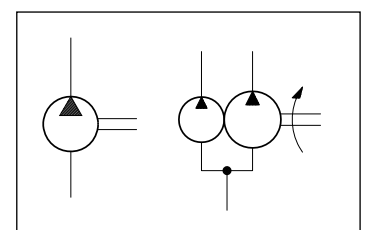



1 - IDENTIFICATION CODE FOR SINGLE PUMPS

FV7		S	-		-				/ 10		-	
------------	--	----------	----------	--	----------	--	--	--	-------------	--	----------	--

Fixed displacement vane pump

Pump size: _____
B = from 5.8 to 50 cm³/rev
D = from 44 to 137.5 cm³/rev

Mounting flange: _____
 SAE J744

Cartridge size: _____
 see paragraph 2

Shaft end type _____
FV7BS:
1 = cylindrical keyed SAE B
3 = splined SAE B
4 = splined SAE B-B

FV7DS:
1 = cylindrical keyed SAE C
2 = cylindrical keyed - no SAE
3 = splined SAE C
4 = splined SAE C special

Rotation direction _____
 (view from shaft side)
R = clockwise
L = counterclockwise

For FV7BS only:
 Delivery port size
00 = 1"
01 = 3/4"

Seals:
N = NBR seals for mineral oils (**standard**)
V = FPM seals for special fluids

Series No.
 (the overall and mounting dimensions remain unchanged from 10 to 19)

Ports position
 (view from shaft side)
 Delivery port always on top
00 = opposed (**standard**)
01 = in line
02 = 90° CW from P port
03 = 90° CCW 90° CW from P port

Ports position

00 P S	01 P-S	02 P S	03 P S
------------------	---------------	------------------	------------------



2 - PERFORMANCES

(obtained with antiwear mineral oil with viscosity of 24 cSt)

PUMP	CARTRIDGE SIZE	DISPLACEMENT [cm ³ /rev]	MAX FLOW RATE at 0 bar - 1500 rpm [l/min]	PRESSURE [bar]		ROTATION SPEED [rpm]	
				continuous	peak	max	min
FV7BS	02	5.8	8.7	320	350	3600	600
	03	9.8	14.7				
	04	12.8	19.2				
	05	15.9	23.9				
	06	19.8	29.7				
	07	22.5	33.8				
	08	24.9	37.4				
	10	31.8	47.7				
	12	41	61.5	275	300	3000	
	15	50	75	240	280		
FV7DS	14	44	66	250	300	3000	600
	17	55	82.5				
	20	66	99				
	22	70.3	105.5				
	24	81.1	121.7				
	28	90	135				
	31	99.2	148.8				
	35	113.4	170.1				
	38	120.6	180.9	280	2800		
	42	137.5	206.3	230	260	2500	



3 - IDENTIFICATION CODE FOR DOUBLE PUMPS

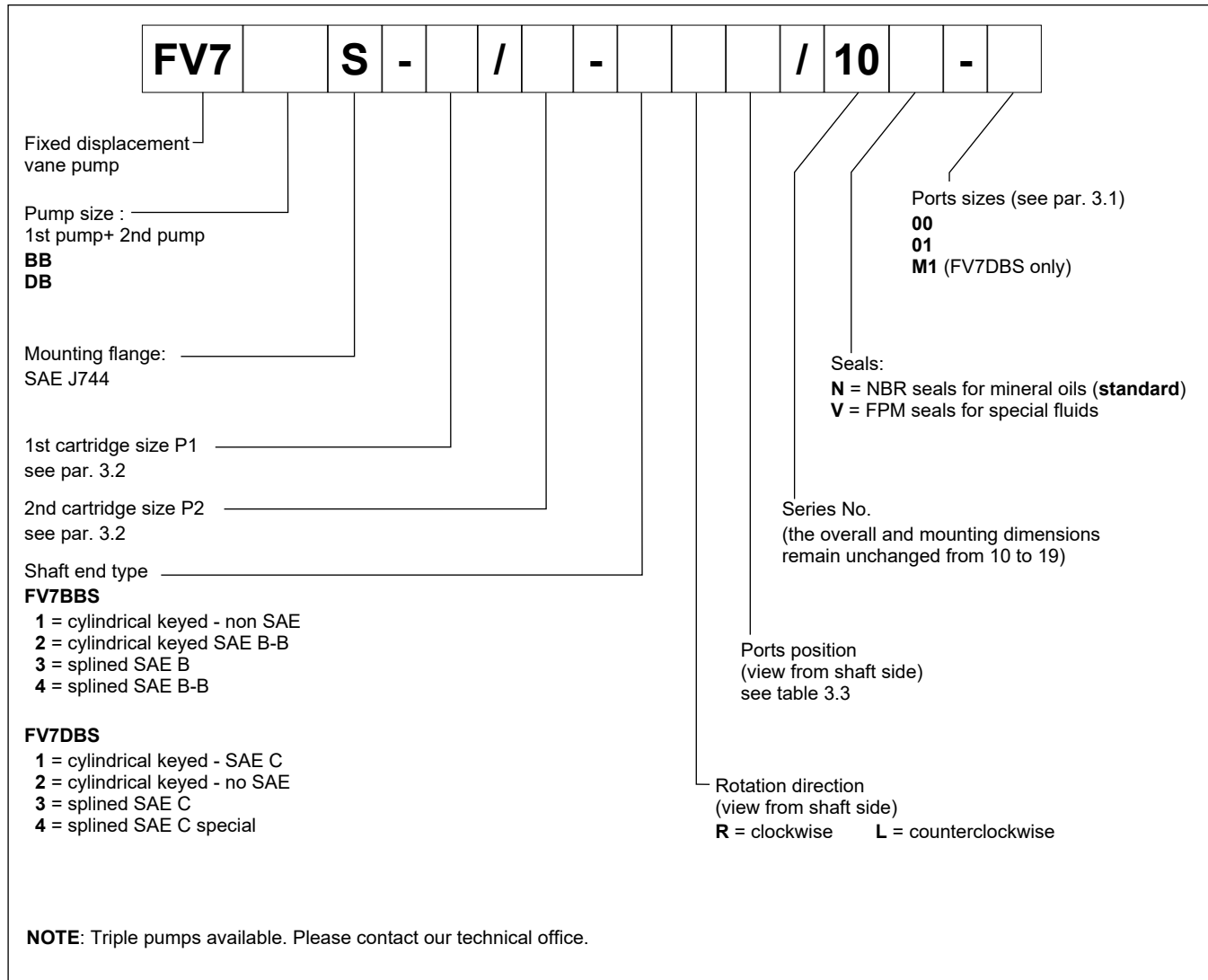

3.1 - Ports sizes

FV7BBS			
	P1	P2	S
00	1"	3/4"	2" 1/2
01	3/4"		

FV7DBS			
	P1	P2	S
00	1" 1/4	1"	3"
01	1" 1/4	3/4"	
M1			

NOTE : M1 version is metric threaded

3.2 - Available cartridges

Grey boxes indicates reduced performance. See paragraph 2 for limits.

The second cartridge (for P2) should have equal or lower displacement than the first.

BB		DB	
1st cartridge	2nd cartridge	1st cartridge	2nd cartridge
02	02	14	02
03	03	17	03
04	04	20	04
05	05	22	05
06	06	24	06
07	07	28	07
08	08	31	08
10	10	35	10
12	12	38	12
15	15	42	15

3.3 - Ports position codes

FV7BBS FV7DBS	00	01	02	03	04	05	06	07
	P1-P2 	P1-P2 	P1-P2-S 	P1-P2 	P1 	P1 	P1 	P1-S
	08	09	10	11	12	13	14	15
	P1-S 	P1-S 	P1 	P1 	P1 	P1 	P1 	P1
16	17	18	19	20	21	22	23	
P1 	P1 	P1 	P1 	P1 	P1 	P1 	P1 	
24	25	26	27	28	29	30	31	
P1-S 	P1-S 	P1-S 	P1-S 	P1 	P1 	P1 	P1 	

4 - HYDRAULIC FLUID

Data in this catalogue are obtained with antiwear fluid petroleum base. Minimum allowable inlet pressure 0,8 absolute bar (-0,2 relative bars). Differential pressure between inlet and outlet pressure should be at least 1.5 bar.

Pressures, maximum allowed speeds and recommended temperatures are shown in the table below, according to the types of hydraulic fluid used.

FLUID TYPE	NOTES
HFC (water glycol solutions with proportion of water ≤ 40%)	<p>The performance ratings shown in the table 'PERFORMANCES' must be reduced as follows:</p> <p>max continuous pressure: 140 bar max peak pressure: 175 bar max rotation speed: 1800 rpm</p> <p>- Minimum allowable inlet pressure 1 absolute bar - The fluid maximum temperature must be between 10°C and 50°C. - Use NBR seals only. - Minimum viscosity 18 cSt</p>
HFD (phosphate esters)	<p>The performance ratings shown in the table 'PERFORMANCES' must be reduced as follows:</p> <p>max continuous pressure: 210 bar max peak pressure: 240 bar max rotation speed: 1800 rpm</p> <p>- Minimum allowable inlet pressure 1,08 absolute bar - The fluid temperature must be between -18°C and 70°C. - Use VITON seals - Minimum viscosity 18 cSt</p>

4.2 - Fluid viscosity

The operating fluid viscosity must be within the following range:

minimum viscosity	10 cSt	referred to the maximum temperature of 90 °C of the fluid, with antiwear
optimum viscosity	30 cSt	referred to the operating temperature of the fluid in the tank
maximum viscosity	840 cSt	limited to only the pump start-up phase at cold start.

When choosing the fluid type, verify that the true viscosity at the operating temperature is within the above range.

4.3 - Degree of fluid contamination

The degree of fluid contamination must be according to ISO 4406:1999 class 19/17/14 or better. Strainers on inlet port are not recommended. However, if requested, do not exceed 149 micron (100 mesh).

5 - CHARACTERISTIC CURVES OF SINGLE PUMPS

5.1 - FV7B

INTERNAL LEAKAGE (typical)

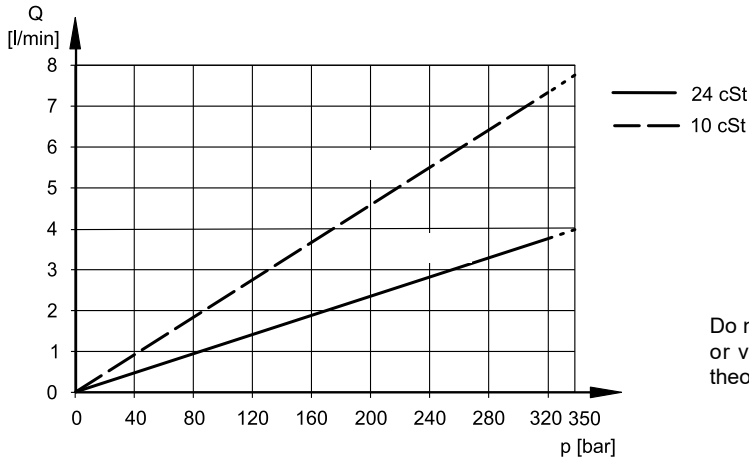

Do not operate the pump more than 5 seconds at any speed or viscosity if the internal leakage is more than 50% of theoretical flow.

PERMISSIBLE RADIAL LOAD

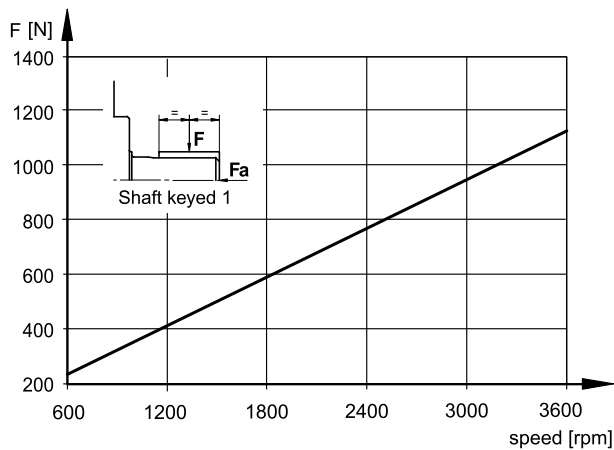

Maximum permitted axial load $F_a = 800$ N

NOISE LEVEL (typical)

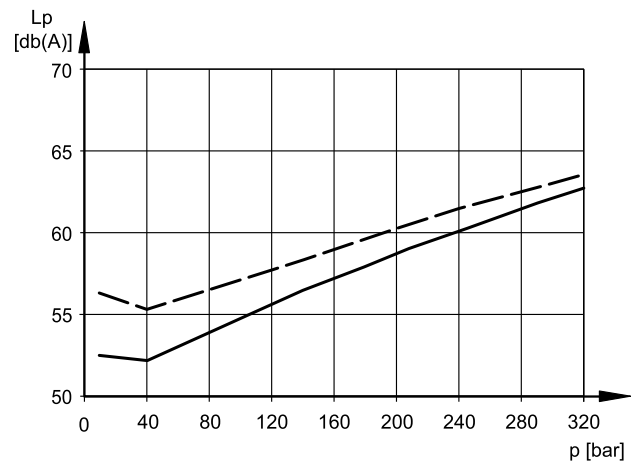

Value obtained with a FV7BS-10 pump, according to ISO 4412 1 mt distance

POWER LOSS HYDROMECHANICAL (typical)

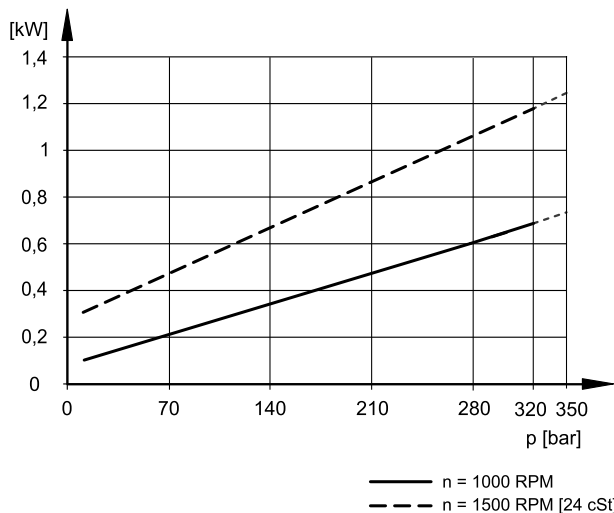

ABSORBED POWER at 1500 rpm

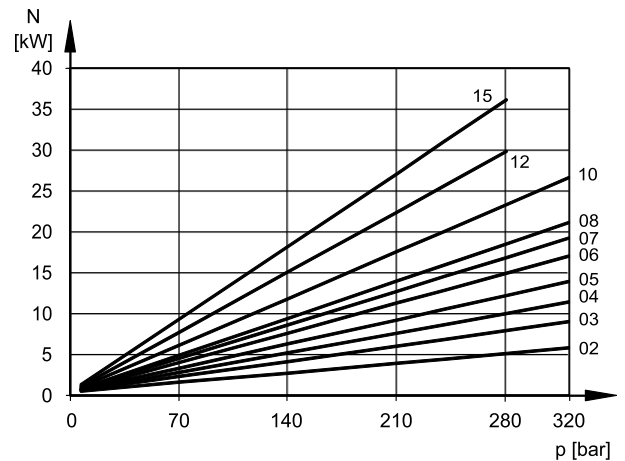

5.2 - FV7D

INTERNAL LEAKAGE (typical)

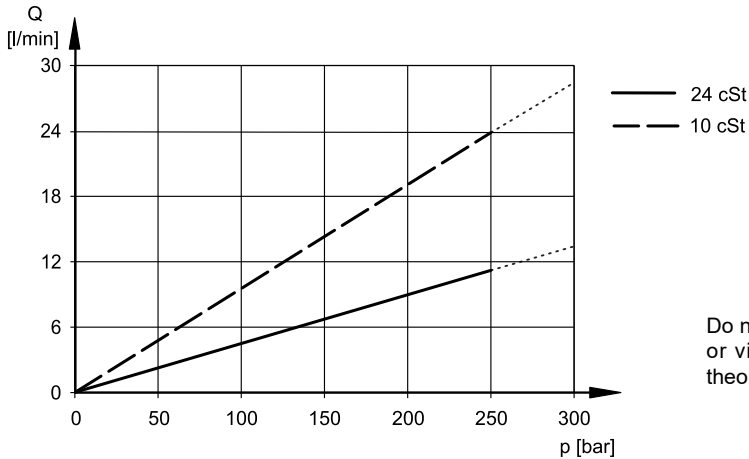

Do not operate the pump more than 5 seconds at any speed or viscosity if the internal leakage is more than 50% of theoretical flow.

PERMISSIBLE RADIAL LOAD

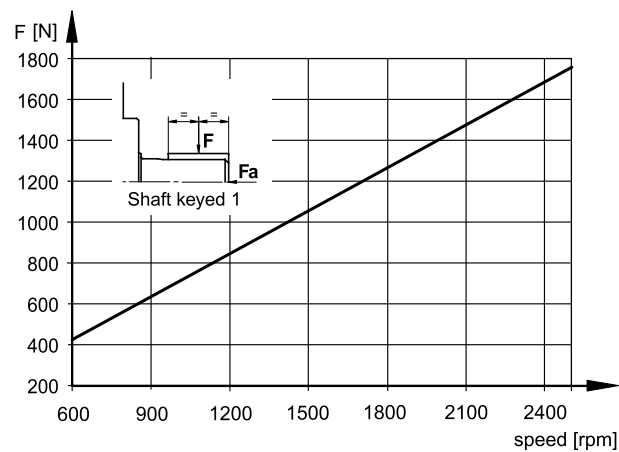

Maximum permitted axial load $F_a = 1200$ N

NOISE LEVEL (typical)

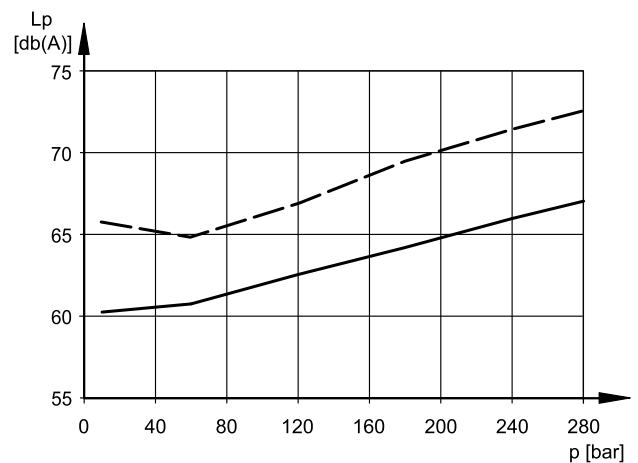

Value obtained with a FV7DS-31 pump, according to ISO 4412 1 mt distance

POWER LOSS HYDROMECHANICAL (typical)

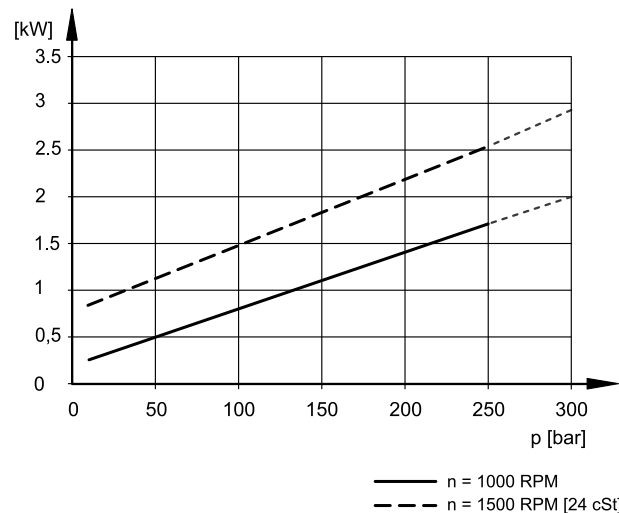

ABSORBED POWER at 1500 rpm

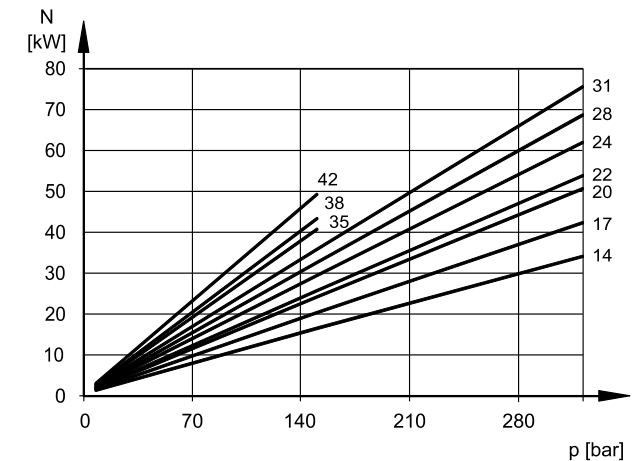

6 - CHARACTERISTIC CURVES OF DOUBLE PUMPS

6.1 - FV7BBS

INTERNAL LEAKAGE (typical)

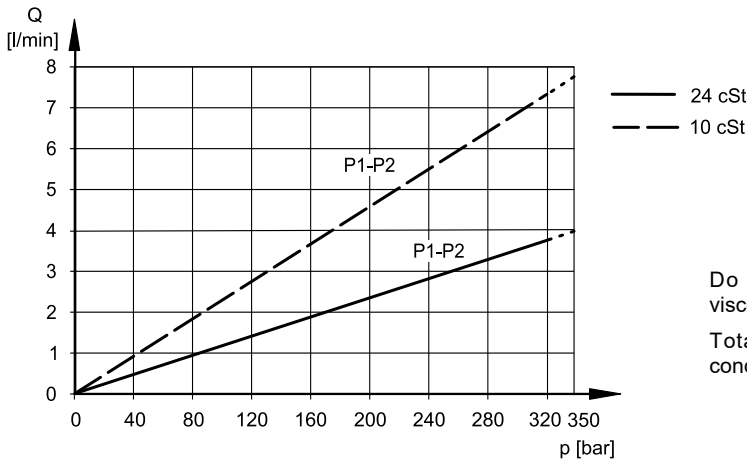

Do not operate pump more than 5 seconds at any speed or viscosity if the internal leakage is more than 50% of theoretical flow
Total leakage is the sum of each section loss at its operating conditions.

PERMISSIBLE RADIAL LOAD

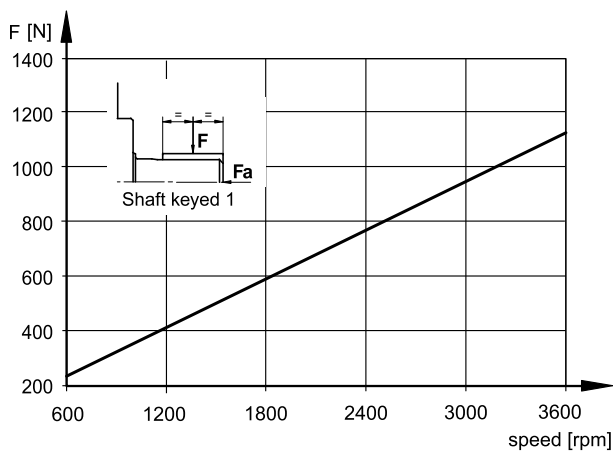

Maximum permitted axial load $F_a = 800$ N

NOISE LEVEL (typical)

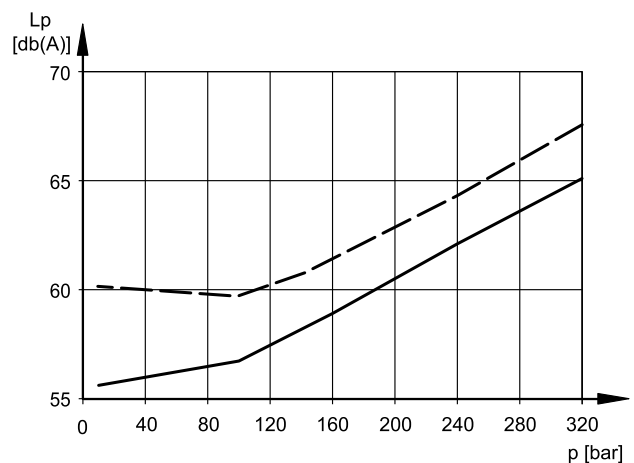

FV7BBS-10-04 pump, according to ISO 4412, 1 mt distance.

Values obtained with $p_e = 0.9$ bar abs and both stages discharging at the same pressure.

POWER LOSS HYDROMECHANICAL (typical)

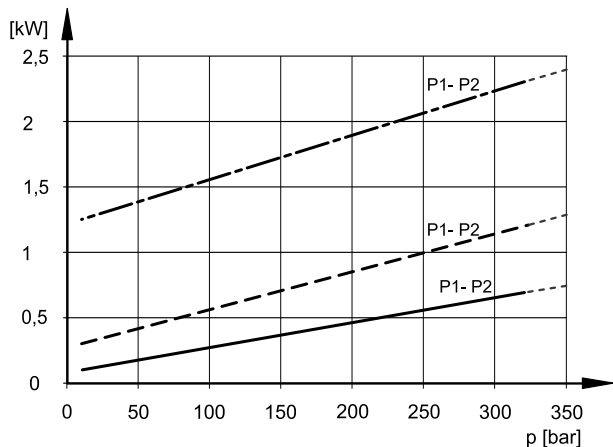

Total hydromechanics power loss is the sum of each section at its operating conditions.

— n = 1000 RPM
- - n = 1500 RPM [24 cSt]
- · - n = 2800 RPM

6.2 - FV7DB

INTERNAL LEAKAGE (typical)

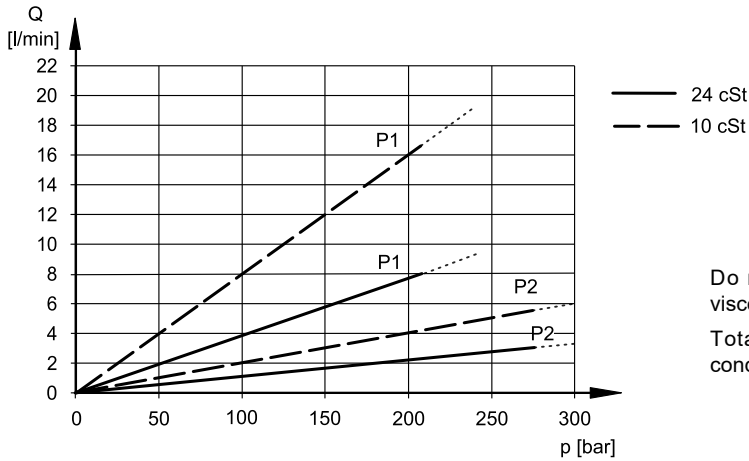

Do not operate pump more than 5 seconds at any speed or viscosity if the internal leakage is more than 50% of theoretical flow
Total leakage is the sum of each section loss at its operating conditions.

PERMISSIBLE RADIAL LOAD

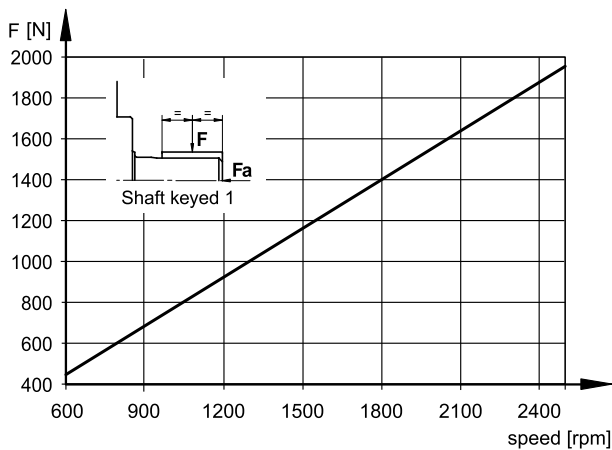

Maximum permitted axial load $F_a = 1200$ N

NOISE LEVEL (typical)

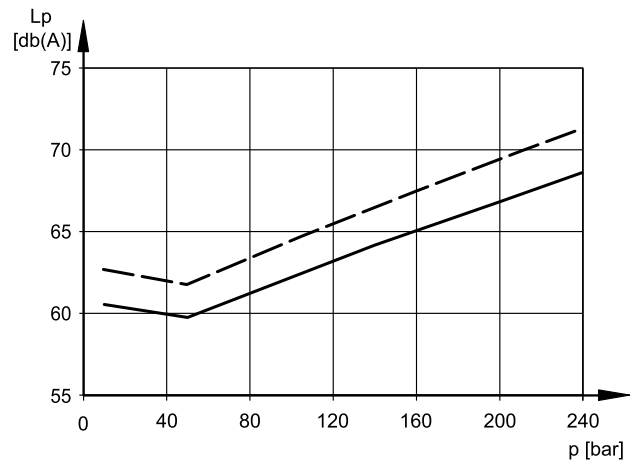

FV7DBS-31-10 pump, according to ISO 4412, 1 mt distance.

Values obtained with $p_e = 0.9$ bar abs and both stages discharging at the same pressure.

POWER LOSS HYDROMECHANICAL (typical)

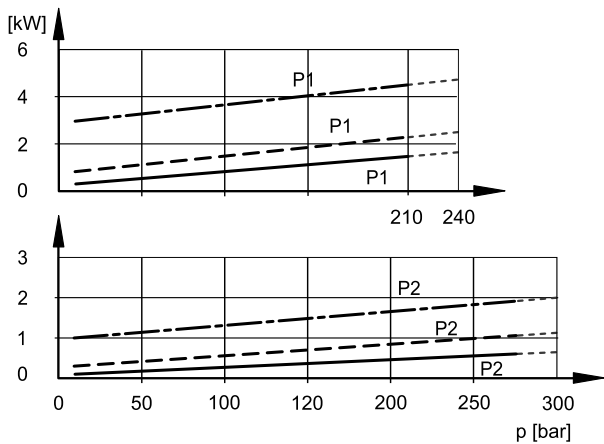

Total hydromechanics power loss is the sum of each section at its operating conditions.



7 - SINGLE PUMPS OVERALL AND MOUNTING DIMENSIONS

7.1 - FV7BS

dimensions in mm

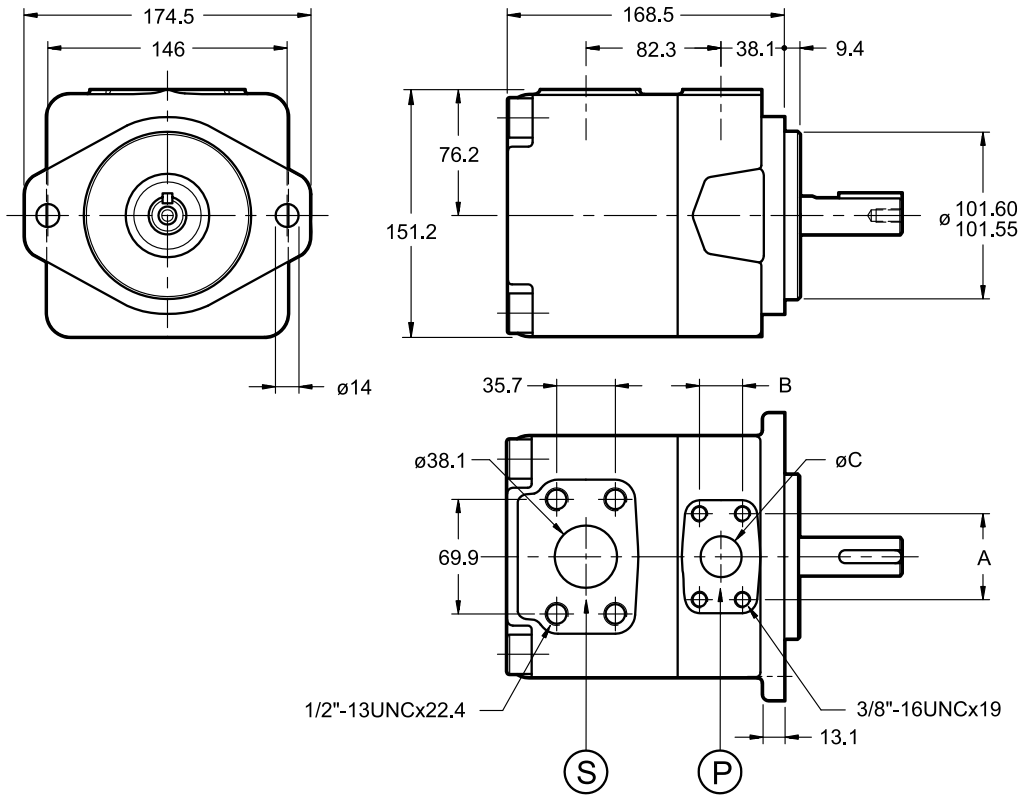

SHAFTS:

cylindrical keyed SAE B
(identification code: 1)

splined SAE B
16/32 d.p. - 13T
(identification code: 3)

splined SAE B-B
16/32 d.p. - 15T
(identification code: 4)

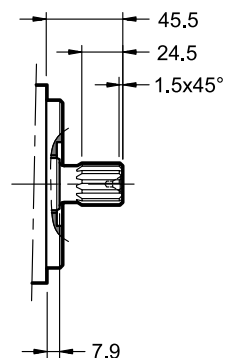
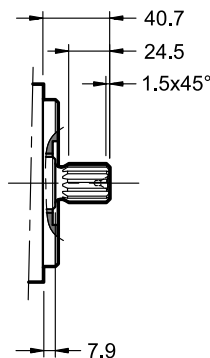
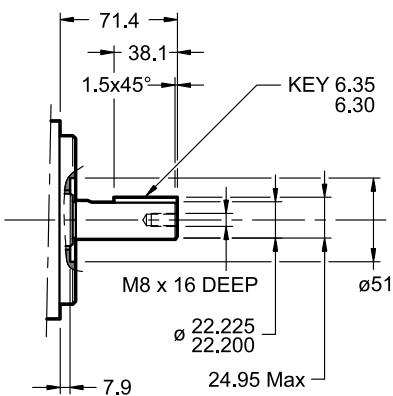

PORTS DIMENSIONS (mm)

code	A	B	ϕC
00	52.4	26.2	25.4
01	47.6	22.2	19.0

7.2 - FV7DS

dimensions in mm

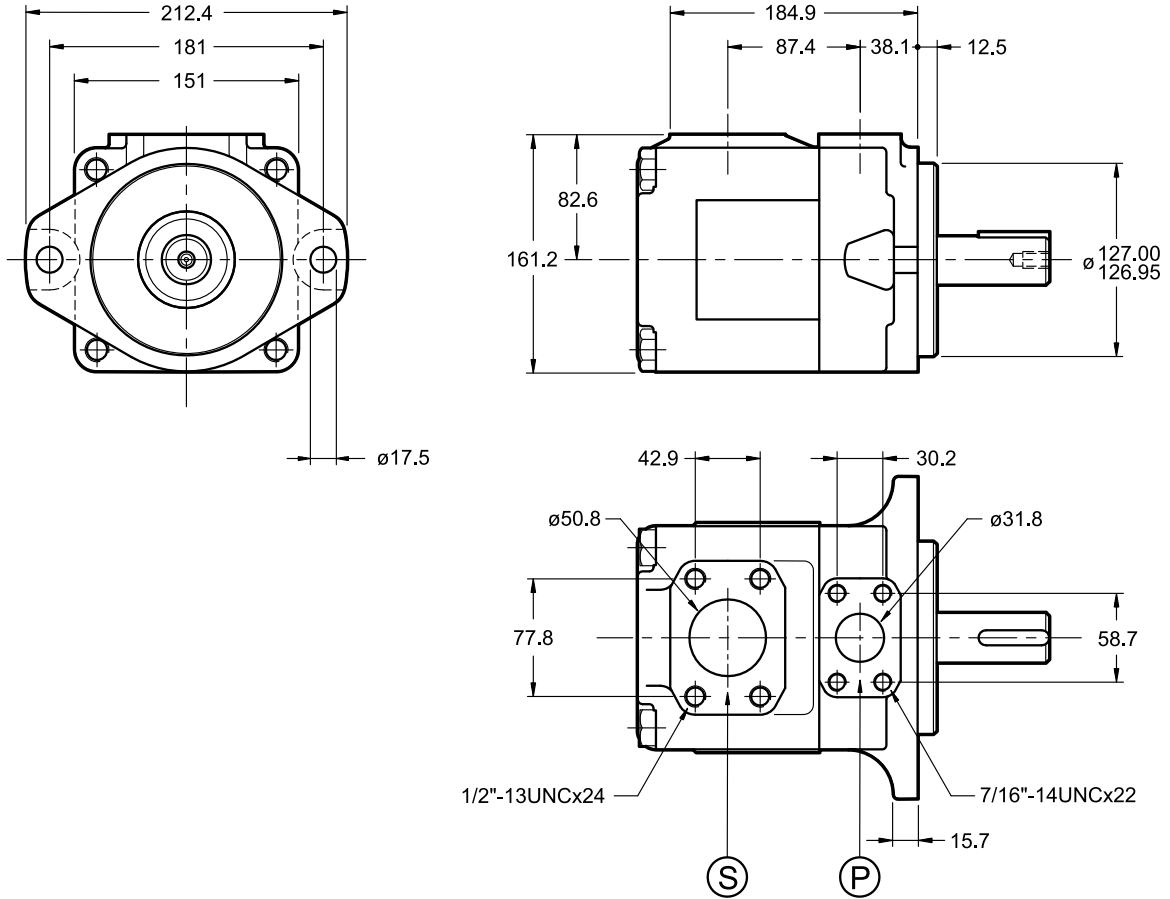

SHAFTS:

cylindrical keyed SAE C
(identification code: 1)

cylindrical keyed - no SAE
(identification code: 2)

splined SAE C
12/24 d.p. - 14T
(identification code: 3)

splined SAE special
12/24 d.p. - 14T
(identification code: 4)

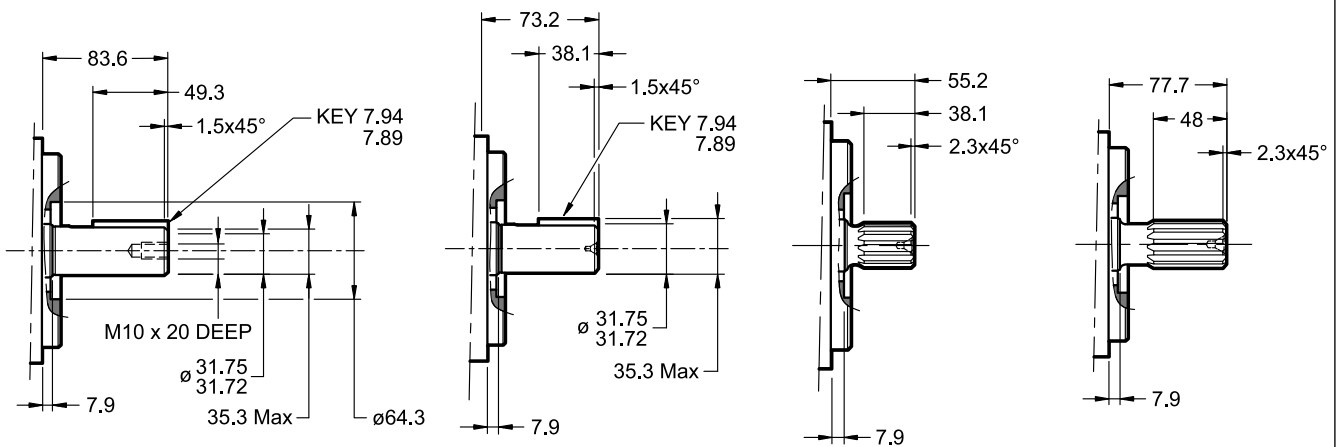

S	Suction port S SAE 2"
P	Pump delivery port P SAE 1" 1/4



8 - DOUBLE PUMPS OVERALL AND MOUNTING DIMENSIONS

8.1 - FV7BBS

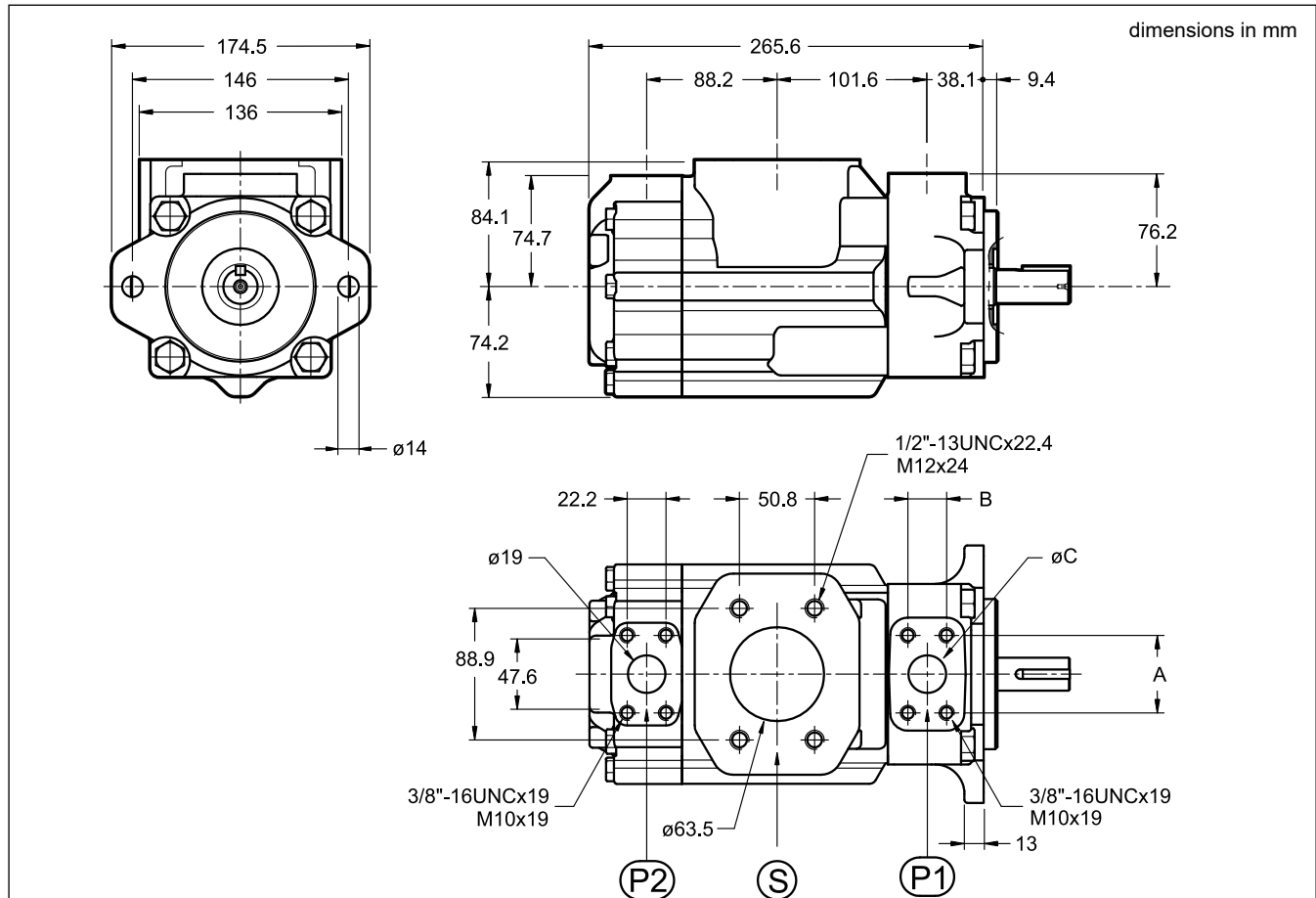

SHAFTS:

cylindrical keyed - no SAE
(identification code: 1)
Torque limit 238 Nm

cylindrical keyed SAE B-B
(identification code: 2)
Torque limit 357 Nm

splined SAE B
16/32 d.p. - 13T
(identification code: 3)

splined SAE B-B
16/32 d.p. - 15T
(identification code: 4)

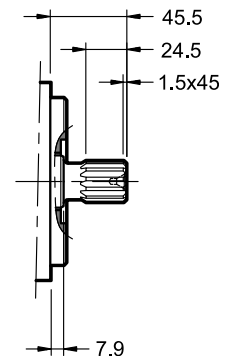
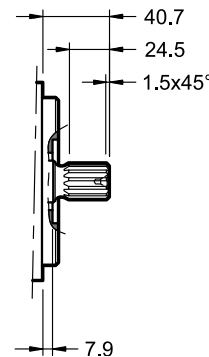
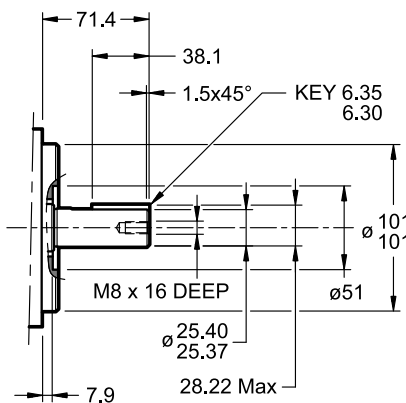
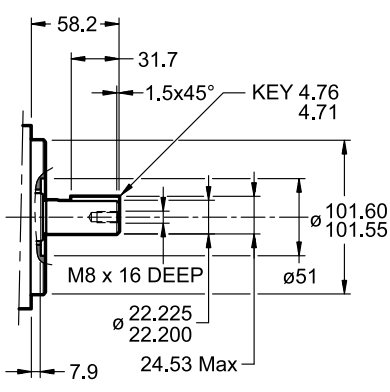

PORTS DIMENSIONS (mm)			
code	A	B	ϕC
00	52.4	26.2	25.4
01	47.6	22.2	19.0

S	Suction port S: SAE 2" 1/2
P1	Delivery port P1: 00: SAE 1" 01: SAE 3/4"
P2	Delivery port P2: SAE 3/4"

8.2 - FV7DBS

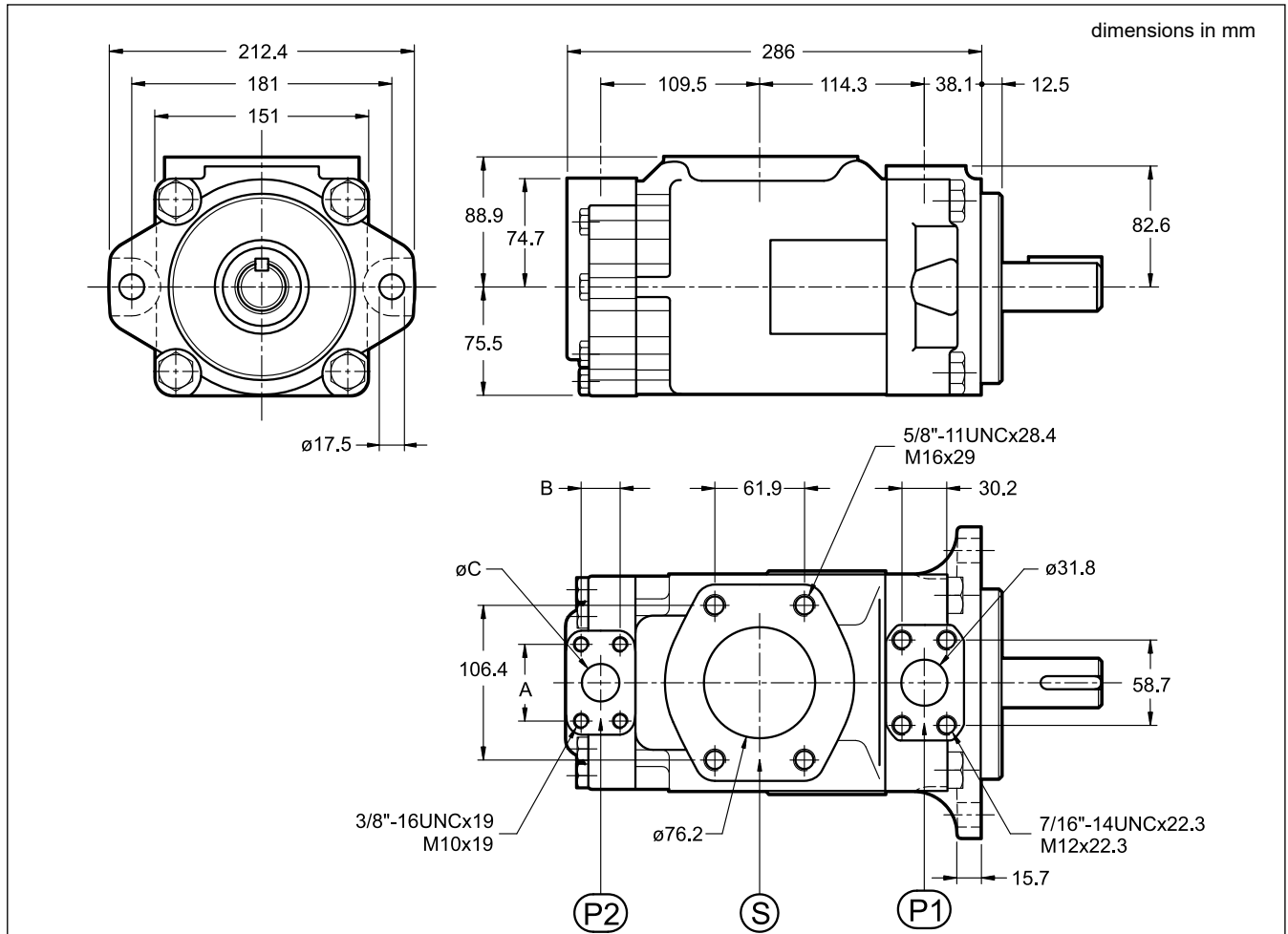

SHAFTS:

cylindrical keyed SAE C
(identification code: 1)
Torque limit 721 Nm

cylindrical keyed - no SAE
(identification code: 2)
Torque limit 577 Nm

splined SAE C
12/24 d.p. - 14T
(identification code: 3)

splined SAE C special
12/24 d.p. - 14T
(identification code: 4)

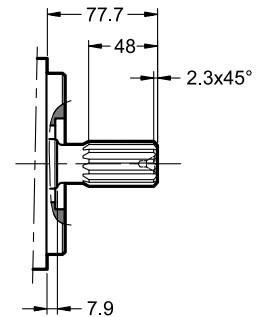
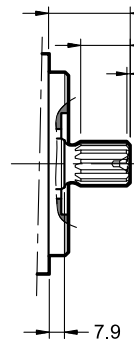
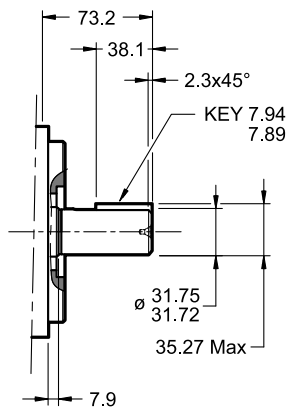
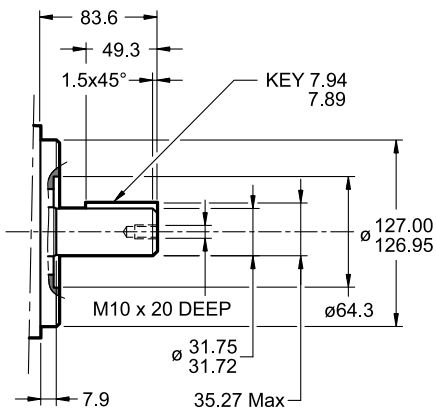

NOTE: M1 version has ports for metric-threaded screws

PORTS DIMENSIONS (mm)			
code	A	B	ϕC
00	52.4	26.2	25.4
01, M1	47.6	22.2	19.0

S	Suction port S: SAE 3"
P1	Delivery port P1: SAE 1" 1/4
P2	Delivery port P2: 00: SAE 1" 01, M1: SAE 3/4"

9 - INSTALLATION AND START-UP

- FV7S pumps can be installed in any position. They are normally positioned directly above the oil tank. The installation below the oil level is suggested for circuits with high flow rates and pressures.
 - The suction line must be sized to facilitate the oil flow. Bends and restrictions or an excessive line length could impair the operation of the pump. A level on both suction and return lines is recommended to increase the surface and so lower the velocity. We suggest a 45° minimum angle.
 - Check the rotation direction of the motor is according to the rotation direction shown on the pump label before start up.
 - The pump start-up should occur with the pump unloaded, especially at cold temperatures. Set the pressure relief valve of the circuit to its minimum setting value so the pump is unloaded when started. Circuit priming and air bleed off have to be performed before resetting the pressure relief valve.
 - A minimum pump shaft speed of 600 rpm is recommended for priming. To prevent possible damage to the internal parts, the pump should never be started dry or without internal lubrication. The pump should prime quite instantly (few seconds). If not, shut down and check conditions.
- Pump with positive head: allow the fluid to flow to the pump inlet, loosen the discharge port(s) fitting(s) until the fluid comes out and retighten the discharge line(s). Then start the pump which should prime quite instantly. Purge the air off the circuit, preferably using air bleed off valves or pressure test points. Let the pump discharge several minutes unloaded.
- Pump mounted above fluid level: fill the pump through outlet port(s) with suitable and clean fluid and start rotation in jog mode. Purge the air off the circuit, preferably using air bleed off valves or pressure test points. Let the pump discharge several minutes unloaded.
- The motor-pump coupling must be made directly with a flexible coupling. Couplings that generate axial or radial loads on the pump shaft are not allowed.
 - Refer to paragraph 4.3 for the characteristics and installation of the filtering elements.

10 - SAE J518 CONNECTION FLANGES

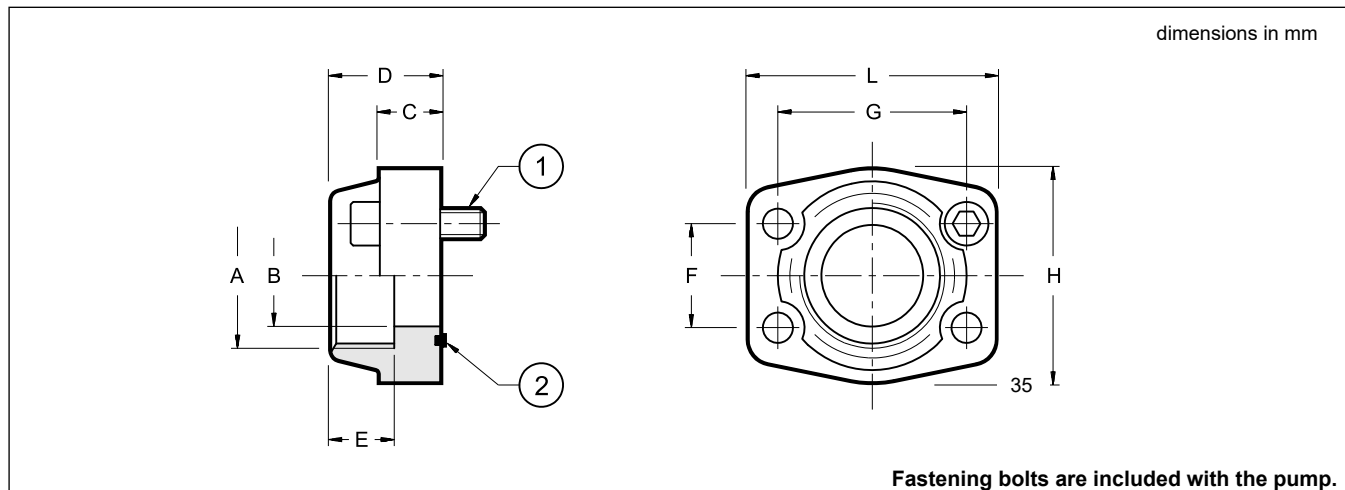

Flange code	Flange description	P _{max} [bar]	ØA	ØB	C	D	E	F	G	H	L	1	2
0610719	SAE - 3/4"	345	3/4" BSP	19	18	36	19	22,2	47,6	50	65	3/8" UNC x 1 1/2"	OR 4100
0610713	SAE - 1"	345	1" BSP	25	18	38	22	26,2	52,4	55	70		OR 4131
0610720	SAE - 1 1/4"	276	1 1/4" BSP	32	21	41	22	30,2	58,7	68	79	7/16" UNC x 1 1/2"	OR 4150
0610714	SAE - 1 1/2"	207	1 1/2" BSP	38	25	45	24	35,7	70	78	93	1/2" UNC x 1 3/4"	OR 4187
0610722	SAE - 2 1/2"	172	2 1/2" BSP	63	25	50	30	50,8	89	105	116		OR 4175
0610723	SAE - 3"	138	3" BSP	73	27	50	34	62	106,4	116	134	5/8" UNC x 2"	OR 4337