

CVM3

CHECK VALVE, DIRECT OPERATED

SERIES 10

MODULAR VERSION ISO 4401-03

p max 350 bar
Q max (see table of performances)

MOUNTING INTERFACE

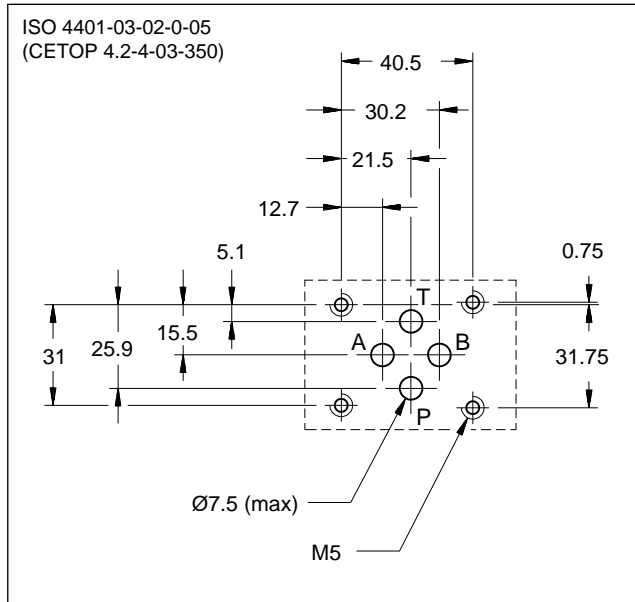

OPERATING PRINCIPLE

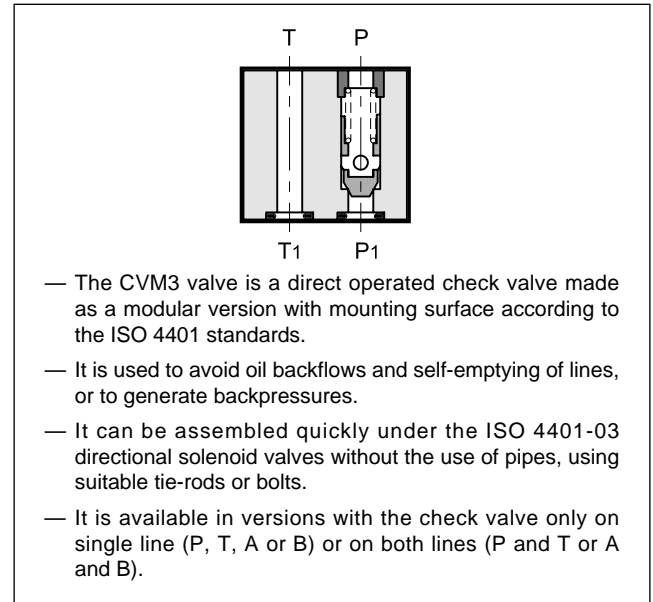

PERFORMANCES

(measured with mineral oil of viscosity 36cSt at 50 °C)

Maximum operating pressure	bar	350
Check valve cracking pressure	bar	0,5 - 3 - 5
Maximum flow rate in controlled lines Maximum flow rate in the free lines	l/min	50 75
Ambient temperature range	°C	-20 / +60
Fluid temperature range	°C	-20 / +80
Fluid viscosity range	cSt	10 ÷ 400
Fluid contamination degree	According to ISO 4406:1999 class 20/18/15	
Recommended viscosity	cSt	25
Mass	kg	1

HYDRAULIC SYMBOLS

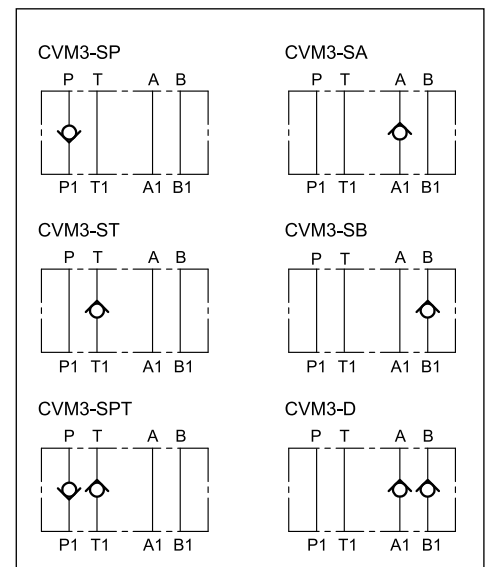

1 - IDENTIFICATION CODE

C	V	M	3	-		/	10		
----------	----------	----------	----------	----------	--	----------	-----------	--	--

Check valve ————
 Modular version ————
 ISO 4401-03 size ————

SP = check valve on line P
SA = check valve on line A
SB = check valve on line B
ST = check valve on line T
SPT = check valves on lines P and T
D = check valves on lines A and B

Option: **/W7** = zinc-nickel surface treatment. Omit if not required (**NOTE**)
 Seals:
N = NBR seals for mineral oils (**standard**)
V = FPM seals for special fluids

Series No. (the overall and mounting dimensions remain unchanged from 10 to 19)
 Cracking pressure:
0.5 = 0.5 bar **3** = 3 bar **5** = 5 bar

NOTE: The standard valve is supplied with surface treatment of phosphating black.
 The zinc-nickel finishing on the valve body makes the valve suitable to ensure a salt spray resistance up to **600** hours.
 (test operated according to UNI EN ISO 9227 standards and test evaluation operated according to UNI EN ISO 10289 standards).

2 - CHARACTERISTIC CURVES (viscosity of 36 cSt at 50 °C)

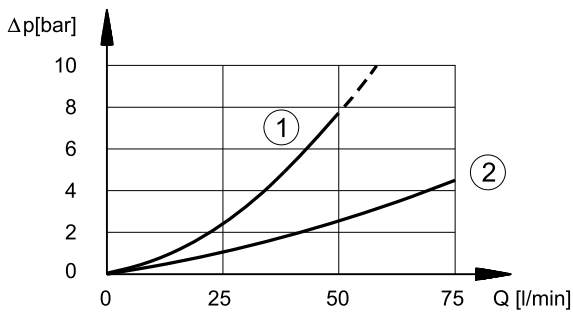

- 1) pressure drops on controlled lines
- 2) pressure drops on free lines

NOTE: check valve cracking pressure must be added to the values indicated in the curve 1 in the diagram.

3 - HYDRAULIC FLUIDS

Use mineral oil-based hydraulic fluids HL or HM type, according to ISO 6743-4. For these fluids, use NBR seals. For fluids HFDR type (phosphate esters) use FPM seals (code V). For the use of other kinds of fluid such as HFA, HFB, HFC, please consult our technical department.

Using fluids at temperatures higher than 80 °C causes a faster degradation of the fluid and of the seals characteristics. The fluid must be preserved in its physical and chemical characteristics.

4 - OVERALL AND MOUNTING DIMENSIONS

dimensions in mm

1	Mounting surface with sealing rings: 4 OR type 2037 (9.25x1.78) - 90 Shore
---	---