



DS3GL

SOLENOID OPERATED DIRECTIONAL VALVE WITH DIGITAL INTERFACE

SUBPLATE MOUNTING ISO 4401-03

p max 350 bar
Q max 80 l/min

MOUNTING INTERFACE

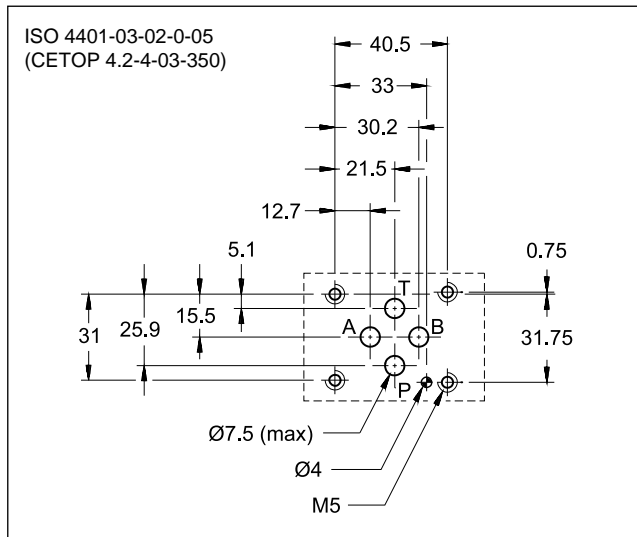

PERFORMANCES

(obtained with mineral oil with viscosity of 36 cSt at 50 °C)

Maximum operating pressure:		350
- P - A - B ports	bar	210
- T port		160
Maximum flowrate	l/min	80
Pressure drops Δp -Q	see point 5	
Operating limits	see point 7	
Electrical features	see point 8	
Electrical connection	M12 5 pin male A	
Ambient temperature range	°C	-20 / +50
Fluid temperature range	°C	-20 / +80
Fluid viscosity range	cSt	10 ÷ 400
Fluid contamination degree	according to ISO 4406:1999 class 20/18/15	
Recommended viscosity	cSt	25
Mass:		
single solenoid valve	kg	1.5
double solenoid valve		2

OPERATING PRINCIPLE

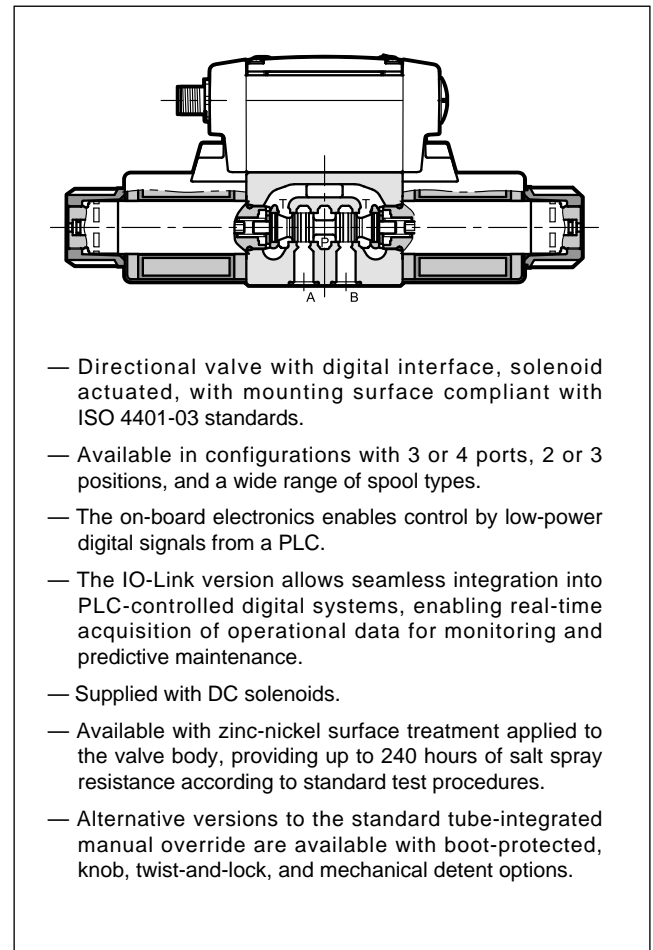

HYDRAULIC SYMBOL (typical)

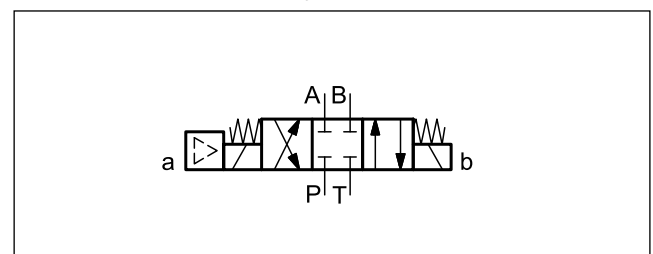

1 - IDENTIFICATION CODE

D	S	3	GL	-	/	-	K12	/		
---	---	---	----	---	---	---	-----	---	--	--

Directional valve, solenoid operated

ISO 4401-03 size

With on-board digital amplifier

Spools types (see point 3)

S*	TA	RK
SA*	TB	
SB*	TA*	
	TB*	

Series No. (the overall and mounting dimensions remain unchanged from 10 to 19):
11 = version with IOL interface
10 = versions with EC1 and EC2 interfaces

Seals:
N = NBR seals for mineral oil (**standard**)
V = FPM seals for special fluids

NOTE: The standard valve is supplied with black phosphating surface treatment. The zinc-nickel coating on the valve body ensures salt spray resistance up to **240** hours (test performed according to UNI EN ISO 9227 and evaluated according to UNI EN ISO 10289 standards).

Option:
/W7 = Zinc-nickel surface treatment (see **NOTE**)
 Omit if not required

Manual override:
 omit for override integrated in the tube (**standard**)
CM = manual override, boot protected
CP = push manual override
CK1 = turning knob override
CK2 = twist and lock knob override
CPK = push manual override with mechanical retention
 Please refer to catalogue 41150 for details on manual overrides

Connection: 5 pin M12, male

Electronic function (see point 2):
IOL = IO-Link interface
EC1 = digital command via PLC for 12V coils
EC2 = digital command via PLC for 24V coils

2 - ELECTRONICS FUNCTIONS

2.1 - IOL version with IO-Link interface

The IOL version controls the valve via the IO-Link communication. Both the control signal and solenoid power are supplied through IO-Link interface. The IOL version operates exclusively at 24 V DC. The IO-Link master must ensure that the port to which the valve is connected can deliver the nominal current specified in Table 8.2.

A data register is available, recording the energizing and de-energizing times of both solenoids.

2.2 - EC* versions

EC1 and EC2 versions allow the solenoid to be controlled by a digital low-power signal from the PLC. The on-board electronics supply the coil with the nominal voltage for the time needed to energize it (up to 300 ms) and move the spool, and then decrease the current to a holding value sufficient to maintain the spool position until the next switching (approx. 70% of the I nom).

Current supplied to the coils by the on-board electronics

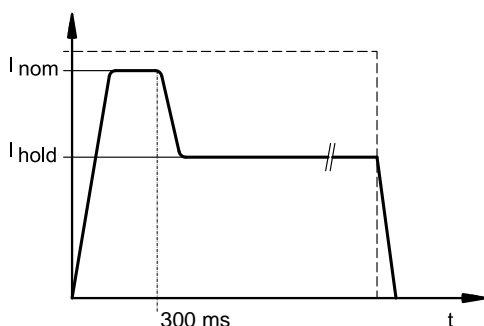

3 - HYDRAULIC FLUIDS

Use mineral oil-based hydraulic fluids HL or HM type, according to ISO 6743-4. For these fluids, use NBR seals (code N). For fluids HFDR type (phosphate esters) use FPM seals (code V). For the use of other fluid types such as HFA, HFB, HFC, please consult our technical department. Using fluids at temperatures higher than 80 °C causes a faster degradation of the fluid and of the seals characteristics. The fluid must be preserved in its physical and chemical characteristics.

4 - SPOOL TYPE

Type S*:
2 solenoids - 3 positions
with spring centreing

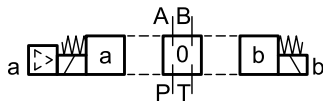

Type SA*:
1 solenoid side A
2 positions (central + external)
with spring centreing

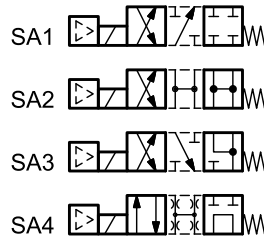
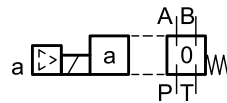

Type SB*:
1 solenoid side B
2 positions (central + external)
with spring centreing

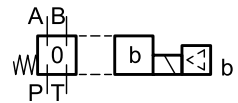

Type TA:
1 solenoid side A
2 external positions
with return spring

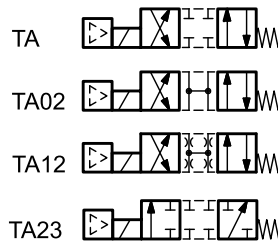
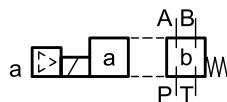

Type TB:
1 solenoid side B
2 external positions
with return spring

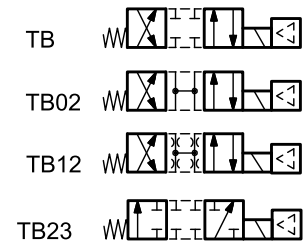
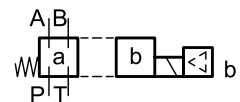

Type RK:
2 solenoids - 2 positions
with mechanical retention

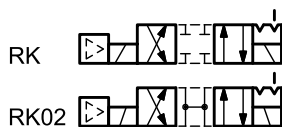
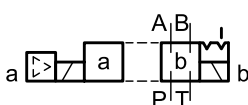

NOTE 1: Besides the diagrams shown, which are the most frequently used, other are available: please refer to catalogue 41 150.

5 - PRESSURE DROPS Δp -Q

(obtained with viscosity 36 cSt at 50 °C)

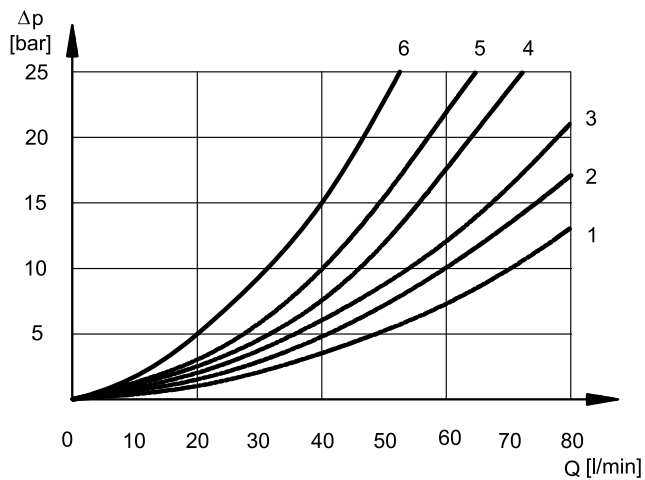

ENERGIZED POSITION

SPOOL TYPE	FLOW DIRECTION			
	P→A	P→B	A→T	B→T
	CURVES ON GRAPH			
S1, SA1, SB1	2	2	3	3
S2, SA2, SB2	1	1	3	3
S3, SA3, SB3	3	3	1	1
S4, SA4, SB4	5	5	5	5
S5	2	1	3	3
S6	2	2	3	1
S7, S8	4	5	5	5
S9	2	2	3	3
S10	1	3	1	3
S11	2	2	1	3
S12, S17	2	2	3	3
S18	1	2	3	3
TA, TB	3	3	3	3
TA02, TB02	2	2	2	2
TA23, TB23	3	3		
RK, RK02	2	2	2	2

For pressure drops between A and B lines of S10 spools used in regenerative diagrams, refer to curve 5.

DE-ENERGIZED POSITION

SPOOL TYPE	FLOW DIRECTION				
	P→A	P→B	A→T	B→T	P→T
	CURVES ON GRAPH				
S2, SA2, SB2					2
S3, SA3, SB3			3	3	
S4, SA4, SB4					3
S5		4			
S6				3	
S7, S8			6	6	3
S10	3	3			
S11			3		
S18	4				

6 - SWITCHING TIMES

The values indicated are obtained according to ISO 6403 standard, with mineral oil viscosity 36 cSt at 50 °C.

TIMES [ms]		
versions	ENERGIZING	DE-ENERGIZING
IOL	set via bus	set via bus
EC1, EC2	25 ÷ 75	15 ÷ 25

7 - OPERATING LIMITS

The curves define the flow rate operating ranges according to the valve pressure for the different versions. The values have been obtained in accordance with ISO 6403, with solenoids at rated temperature and supplied with 90% of the nominal voltage. The values were measured using mineral oil with a viscosity of 36 cSt at a temperature of 50 °C, and filtration compliant with ISO 4406:1999 class 18/16/13.

The limits for TA02 and TA spools refer to 4-port operation. The operating limits of a 4-port valve in 3-port operation, with either port A or B plugged, or with no flow, are shown in the corresponding diagram.

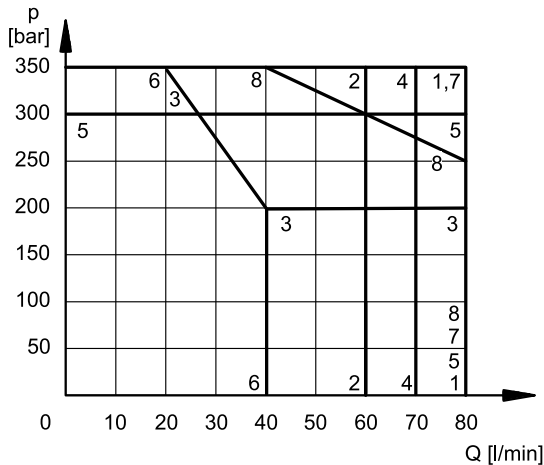

SPOOL	CURVE	
	P→A	P→B
S1, SA1, SB1	1	1
S2, SA2, SB2	2	2
S3, SA3, SB3	3	3
S4, SA4, SB4	4	4
S5	5	5
S6	4	6
S7	4	4
S8	4	4
S9	7	7
S10	7	7
S11	4	6
S12	1	1
S17	4	4
S18	5	5

SPOOL	CURVE	
	P→A	P→B
TA, TB	7	7
TA02, TB02	8	8
TA23, TB23	2	2
RK	7	7
RK02	8	8

4-PORT VALVE IN 3-PORT OPERATION

Operating limits of a 4-port valve in 3-port operation or with port A or B plugged or without flow.

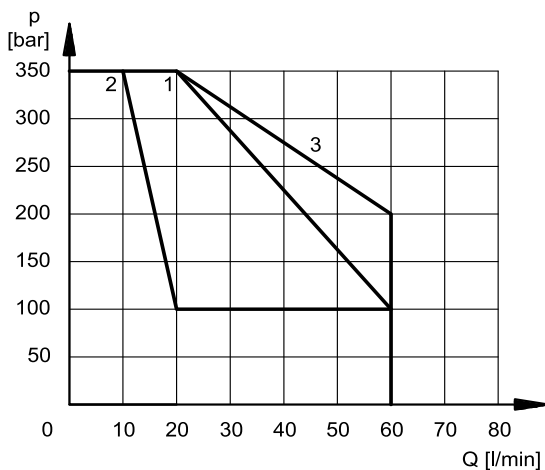

SPOOL	CURVE
TA backpr. A; TB backpr. B	1
TA02 backpr. A; TB02 backpr. B	1
TA backpr. B; B backpr. A	2
TA02 backpr. B; TB02 backpr. A	3

8 - ELECTRICAL FEATURES

8.1 - Solenoids

The solenoids are composed of two primary components: the tube and the coil.

The tube is threaded into the valve body and contains the armature, which moves within the oil without any wear. The inner section, in contact with the oil in the return line, facilitates heat dissipation.

The coil is securely mounted to the tube using a threaded ring and can be easily replaced.

Protection from atmospheric agents IEC 60529

The IP protection degree is guaranteed only with both valve and connectors of an equivalent IP degree, correctly connected and installed.

electric connection	electric connection protection	whole valve protection
K6 - 2 pins for junction box	IP65	IP65

SUPPLY VOLTAGE FLUCTUATION	± 10% Vnom
MAX SWITCH ON FREQUENCY	18.000 ins/hr
DUTY CYCLE	100%
ELECTROMAGNETIC COMPATIBILITY (EMC)	In compliance with 2014/30/EU
LOW VOLTAGE	In compliance with 2014/35/EU
CLASS OF PROTECTION Coil insulation (VDE 0580) Impregnation	class H class F

8.2 - Current and absorbed power

The table shows current and power consumption values for each function (values ± 10%).

Function	Supply voltage [V]	Current consumption (RMS) [A]		Power absorption (RMS) [W]		Coil nominal voltage [V]	Resistance at 20°C [ohm]	Coil code
		I nom	I hold	P nom	P hold			
EC1	12	2.2	1.8	26.4	21.5	12	4.5	1904060
EC2, IOL	24	1.2	0.85	29	20.5	24	18.6	1903801

8.3 - IOL function: IO-Link communication

2L- and 1L- pin are galvanic isolated up to 100 V to avoid earth loops. In IO-Link networks, the length of the connecting cables is limited to 20 metres.

Supply voltage	V DC	24 (from 19 to 30 VDC), ripple max 3 Vpp
IO-Link communication (IOL): Data rate	kBaud	IO-Link Port Class B 38.4
Managed breakdowns		overload and electronics overheating, cable breakdown, supply voltage failures
Connection		5-pin M12 code A (IEC 61076-2-101), male

8.4 - IOL pin table



Pin	Values	Function
2	2L+ +24 V DC	Solenoid voltage supply
5	2L- 0 V (GND)	
1	1L+ +24 V DC	IO-Link voltage supply
3	1L- 0 V (GND)	
4	C/Q	IO-Link Communication

8.5 - IOL on-board electronics diagram

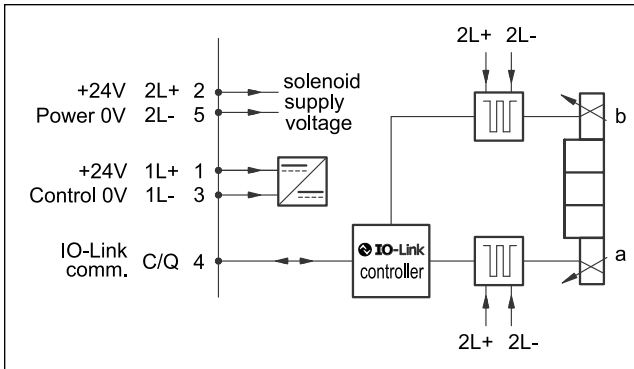

8.6 - IOL functions: LED

The valve has two visible LEDs. Only one LED is active at a time.

led	colour	ON	Blink
L1	green	-	IO-Link connection OK
	red		no IO-Link connection
L2	green	ch A ON	-
	orange	ch B ON	
	red		error

8.7 - EC* functions: electrical characteristics

Supply voltage:	EC2 EC1	V DC	24, ripple max 3 Vpp 12, ripple max 3 Vpp
Power consumption		W	1 + solenoid consumption (see p. 8.2)
Fuse protection, external		A	3
Managed breakdowns			overload and electronics overheating, supply voltage failures

8.8 - EC1 pin table

Pin	Values	Function
1	8 ÷ 12 V DC	Digital command coil B
2	+12 V DC	Solenoid supply voltage
3	NC	-
4	8 ÷ 12 V DC	Digital command coil A
5	0V GND	Supply voltage reference

8.9 - EC2 pin table

Pin	Values	Function
1	8 ÷ 24 V DC	Digital command coil B
2	+24 V DC	Solenoid supply voltage
3	NC	-
4	8 ÷ 24 V DC	Digital command coil A
5	0V GND	Supply voltage reference

8.10 - EC* on-board electronics diagram

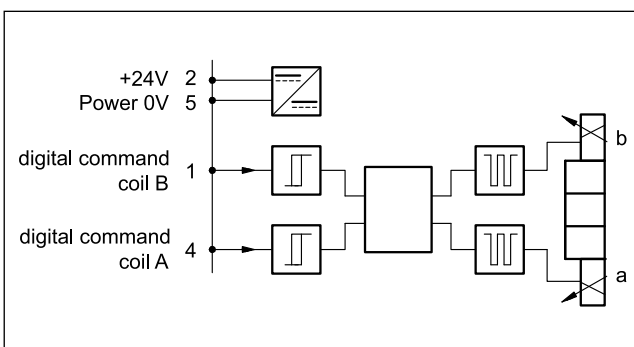

8.11 - EC* functions: LED

The valve has two visible LEDs.

led	colour	ON	Blink
L1	red	-	Powered valve
L2	green	ch A ON	-
	orange	ch B ON	-
	red	-	Error

9 - ELECTRIC CONNECTORS

A 5-poles M12 code A female connector is required. It can be ordered separately with code 3491001001. See catalogue 89 000 for details.

10 - OVERALL AND MOUNTING DIMENSIONS

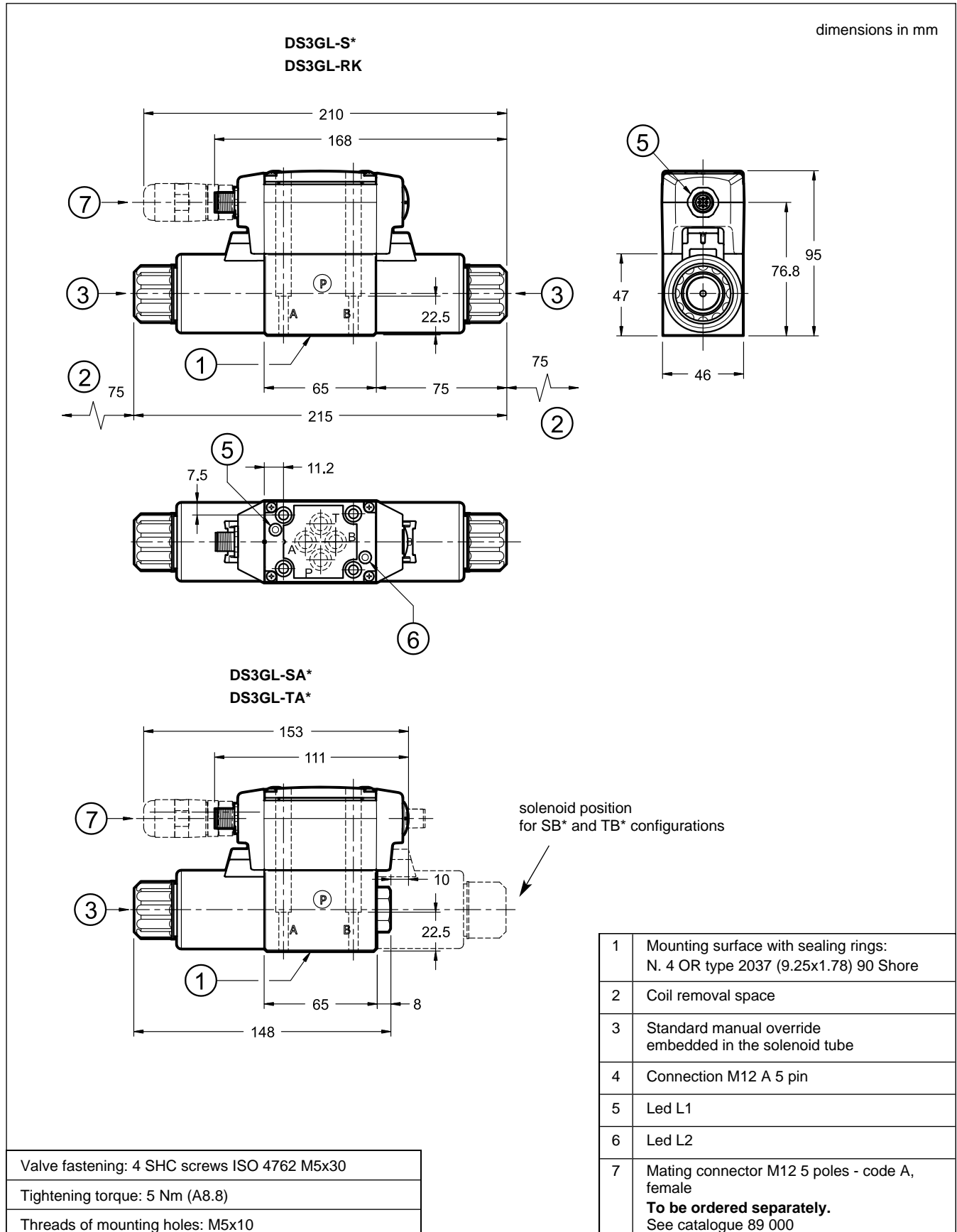

11 - INSTALLATION

Configurations with centering and return springs can be mounted in any position. For RK valves, which do not have springs and feature a mechanical detent, the valve must be installed with the spool in a horizontal position.

The valve is fixed using screws or tie rods and should be mounted on a lapped surface. The surface flatness and smoothness should meet or exceed the values indicated in the drawing. If the minimum requirements for flatness and/or smoothness are not met, fluid leakage between the valve and the mounting surface may occur.

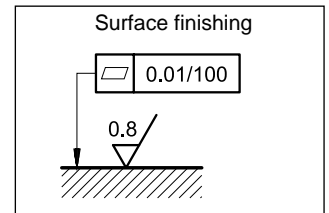

12 - SUBPLATES

(see catalogue 51 000)

Type PMMD-AI3G with rear ports 3/8" BSP
Type PMMD-AL3G with side ports 3/8" BSP



DS3GL

DUPLOMATIC
MOTION SOLUTIONS
*a member of **DAIKIN** group*

DUPLOMATIC MS Spa

via Mario Re Depaolini, 24 | 20015 Parabiago (MI) | Italy

T +39 0331 895111 | E vendite.ita@duplomatic.com | sales.exp@duplomatic.com

duplomaticmotionsolutions.com