

DSP1*

DIRECTIONAL VALVES, PILOT OPERATED, SOLENOID OR HYDRAULIC (DSC1*) ACTUATED

SUBPLATE MOUNTING

DS*10 ISO 4401-10

DS*11 ISO 4401-10 oversize ports

p max 350 bar

Q max 1600 l/min

OPERATING PRINCIPLE

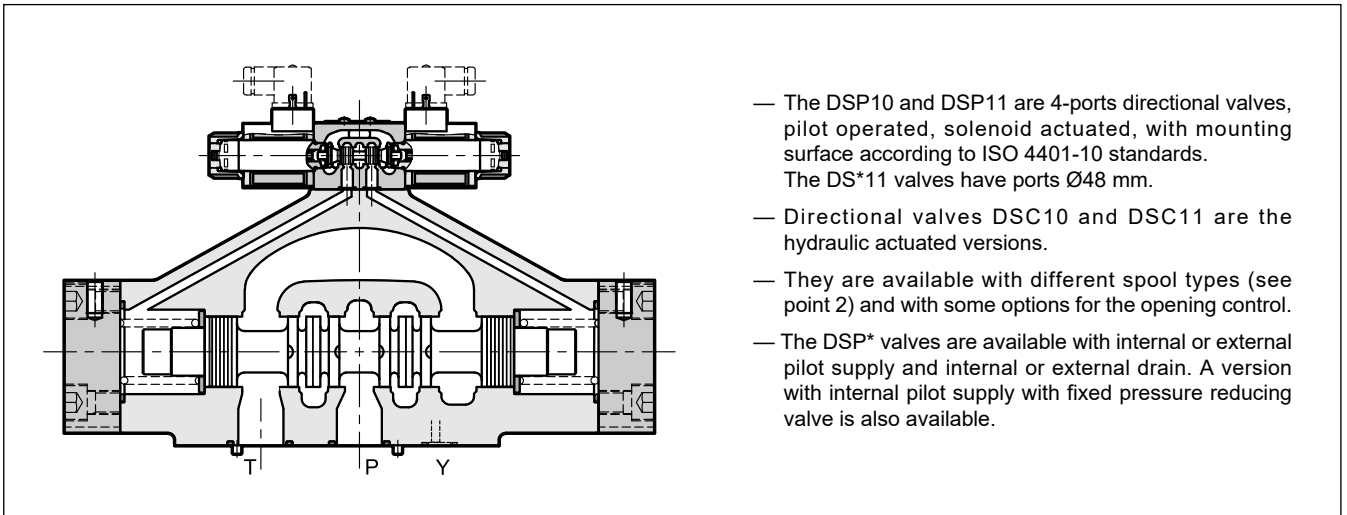

- The DSP10 and DSP11 are 4-ports directional valves, pilot operated, solenoid actuated, with mounting surface according to ISO 4401-10 standards. The DS*11 valves have ports Ø48 mm.
- Directional valves DSC10 and DSC11 are the hydraulic actuated versions.
- They are available with different spool types (see point 2) and with some options for the opening control.
- The DSP* valves are available with internal or external pilot supply and internal or external drain. A version with internal pilot supply with fixed pressure reducing valve is also available.

PERFORMANCES

(obtained with mineral oil of viscosity of 36 cSt at 50°C)

		DS*10	DS*10H	DS*11
Maximum operating pressure	bar	350	420	320
- ports P - A - B (standard version)		300	350	250
- port T (external drainage) - port T (internal drainage)		210 (CC) / 160 (CA)	210 (CC) / 160 (CA)	210 (CC) / 160 (CA)
Maximum flow rate from port P to A - B - T	l/min	1100	1100	1600
Ambient temperature range	°C	-20 / +50		
Fluid temperature range	°C	-20 / +80		
Fluid viscosity range	cSt	10 ÷ 400		
Fluid contamination degree	according to ISO 4406:1999 class 20/18/15			
Recommended viscosity	cSt	25		
Mass: DSP	kg	41.4	41.4	38.6
DSC		40.1	40.1	37.3

1 - IDENTIFICATION CODE FOR SOLENOID ACTUATED DIRECTIONAL VALVES

D	S	P		-	/		-		/		/	K1	/	
----------	----------	----------	--	---	---	--	---	--	---	--	---	-----------	---	--

Pilot operated directional valve, solenoid actuated

10 = ISO 4401-10 size
11 = ISO 4401-10 with oversized ports

Option: _____
(omit for standard version)
H = high pressure p_{max} 420 bar
(not available for DSP11)

Spool type (see point 2) _____
S* **TA**
SA* **TB**
SB* **RK***

Series: _____
22 = for DSP10
12 = for DSP11
(the overall dimensions do not change within the same ten)

Seals: _____
N = NBR seals for mineral oil (**standard**)
V = FPM seals for special fluids

Pilot supply (see points 10 and 11): _____
I = Internal (not available for spools S2 - S4 - TA02 - TB02 - RK02 - S*2 - S*4)
E = External
Z = Internal pilot supply with 30 bar pressure reducing valve, fixed adjustment.

Drain (see points 10 and 11): _____
I = Internal
E = External

Control options (see point 15): _____
C = Main spool stroke control (not available for spool S4)
D = Main spool switching speed control
P15 = Subplate placed under the pilot stage with restrictor of $\varnothing 1.5$ in P port

Manual override:
Omit for override integrated in the tube (**standard**)
CM = Manual override, boot protected (see point 16)

Coil electrical connection:
plug for connector
type EN 175301-803
(ex DIN 43650)

Power supply (see point 8)

Direct current

D12 = 12 V
D24 = 24 V
D48 = 48 V
D110 = 110 V
D220 = 220 V
D00 = Valve without coils (see **NOTE**)

Alternate current

A24 = 24 V - 50 Hz
A48 = 48 V - 50 Hz
A110 = 110 V - 50 Hz / 120 V - 60 Hz
A230 = 230 V - 50 Hz / 240 V - 60 Hz
A00 = Valve without coils (see **NOTE**)
F110 = 110 V - 60 Hz
F220 = 220 V - 60 Hz

NOTE: The locking rings of the coils and the relevant O-rings are supplied.

2 - DSP10 AND DSP11 SPOOLS TYPES

Type S*:
2 solenoids - 3 positions
with spring centering

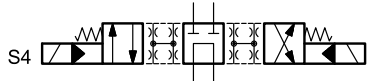
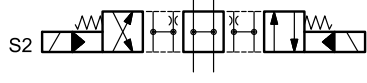
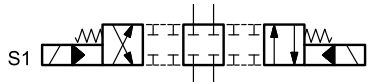
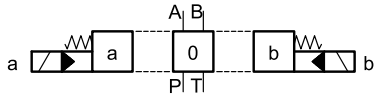

Type SA*:
1 solenoid side A
2 positions (central + external)
with spring centering

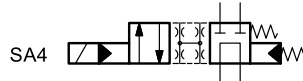
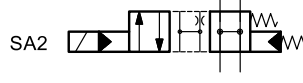
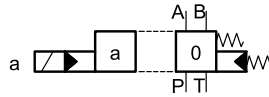

Type SB*:
1 solenoid side B
2 positions (central + external)
with spring centering

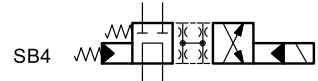
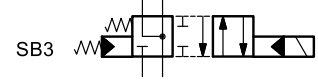
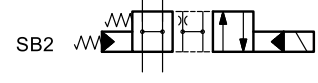
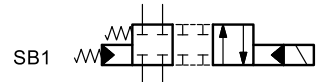
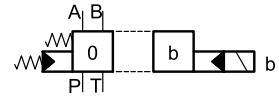

Type RK:
2 solenoids - 2 positions
with mechanical retention

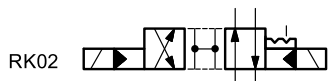
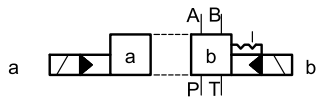

Type TA:
1 solenoid side A
2 external positions
with return spring

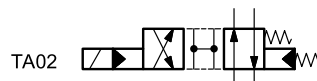
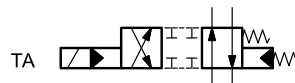
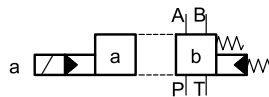

Type TB:
1 solenoid side B
2 external positions
with return spring

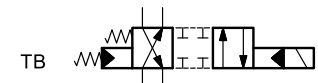
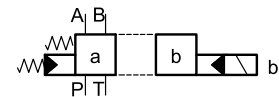

Please consult our Technical Department for other types of spools.

3 - IDENTIFICATION CODE FOR HYDRAULIC ACTUATED DIRECTIONAL VALVES

	D	S	C			-	/	12		-	E	E
--	----------	----------	----------	--	--	----------	----------	-----------	--	----------	----------	----------

Pilot operated directional valve, hydraulic actuated

10 = ISO 4401-10 size
11 = ISO 4401-10 with oversize ports

Option: (omit for standard version)
H = high pressure p_{max} 420 bar (not available for DSP11)

Spool type (see hydraulic symbols below)

S* TA
SA* TB
SB*

External drain (see points 10 and 11)

External pilot supply (see points 10 and 11)

Seals:
N = NBR seals for mineral oil (standard)
V = FPM seals for special fluids

Series:
(the overall and mounting dimensions remain unchanged from 10 to 19)

Spool type
DSC* valves are delivered with short-circuit subplate.
The hydraulic actuation take place by pressurization in X and Y ports.

S*

TA

TB

4 - HYDRAULIC FLUIDS

Use mineral oil-based hydraulic fluids HL or HM type, according to ISO 6743-4. For these fluids, use NBR seals (code V). For fluids HFDR type (phosphate esters) use FPM seals (code V). For the use of other kinds of fluid such as HFA, HFB, HFC, please consult our technical department. Using fluids at temperatures higher than 80 °C causes a faster degradation of the fluid and of the seals characteristics.

The fluid must be preserved in its physical and chemical characteristics.

5 - PRESSURE DROPS Δp -Q

(values obtained with viscosity 36 cSt at 50 °C)

5.1 - DSP10 pressure drops

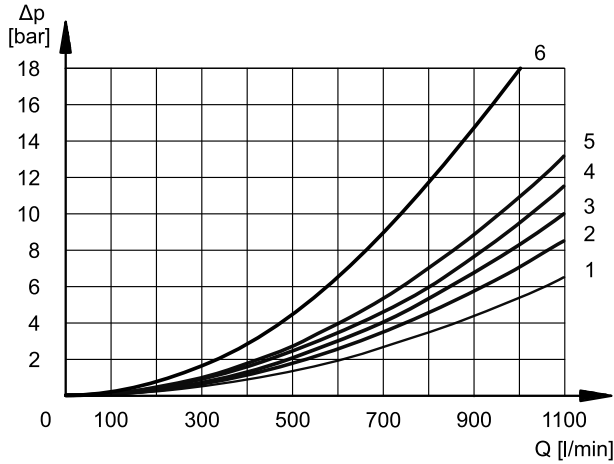

ACTUATED VALVE

SPOOL	FLOW DIRECTIONS				
	P→A	P→B	A→T	B→T	P→T
	CURVES ON GRAPH				
S1, SA1, SB1	3	3	1	2	
S2, SA2, SB2	4	4	2	4	
S3, SA3, SB3	3	3	2	4	
S4, SA4, SB4	3	3	2	4	
TA, TB	3	3	1	2	
TA02, TB02	4	4	2	4	
RK	3	3	1	2	

NORMAL POSITION

SPOOL	FLOW DIRECTIONS				
	P→A	P→B	A→T	B→T	P→T
	CURVES ON GRAPH				
S2			3	4	5
S3			5	5	
S4, TA02					6

5.2 - DSP11 pressure drops

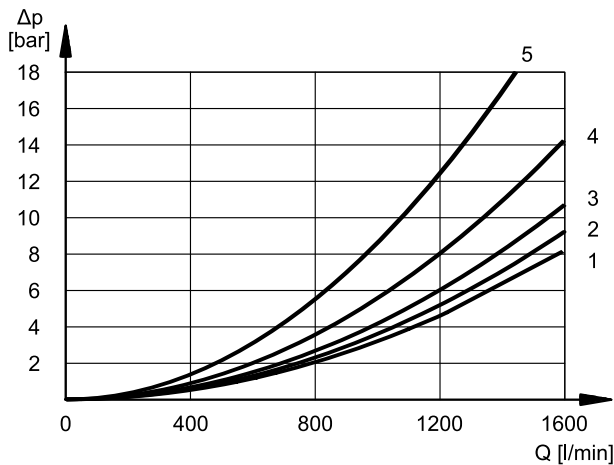

ACTUATED VALVE

SPOOL	FLOW DIRECTIONS				
	P→A	P→B	A→T	B→T	P→T
	CURVES ON GRAPH				
S1, SA1, SB1	1	1	1	2	
S2, SA2, SB2	1	1	1	3	
S3, SA3, SB3	1	1	1	3	
S4, SA4, SB4	1	1	1	3	
TA, TB	1	1	1	2	
TA02, TB02	1	1	1	3	
RK	1	1	1	2	

NORMAL POSITION

SPOOL	FLOW DIRECTIONS				
	P→A	P→B	A→T	B→T	P→T
	CURVES ON GRAPH				
S2			2	2	2
S3			4	4	
S4					5

6 - SWITCHING TIMES

The values indicated refer to a solenoid valve working with piloting pressure of 100 bar, with mineral oil at a temperature of 50°C, at viscosity of 36 cSt and with P→A / B→T connections.

The energizing and de-energizing times are obtained at the pressure variation which occurs on the lines.

TIMES (± 10%) [ms]	ENERGIZED		DE-ENERGIZED	
	2 Pos	3 Pos	2 Pos	3 Pos
AC solenoid	90	60	90	60
DC solenoid	130	100	90	60

7 - OPERATING LIMITS

The curves define the flow rate operating fields according to the valve pressure of the different versions. The values have been obtained according to ISO 6403 norm with solenoids at rated temperature and supplied with voltage equal to 90% of the nominal voltage, with pilot supply pressure of 10 bar

The value have been obtained with mineral oil, viscosity 36 cSt, temperature 50 °C and filtration according to ISO 4406.1999 class 18/16/13.

Limits refer to the 4-port operation. The operating limits of a 4-port valve in 3-port operation, or with port A or B plugged, or without flow may reduce considerably.

7.1 - DSP10

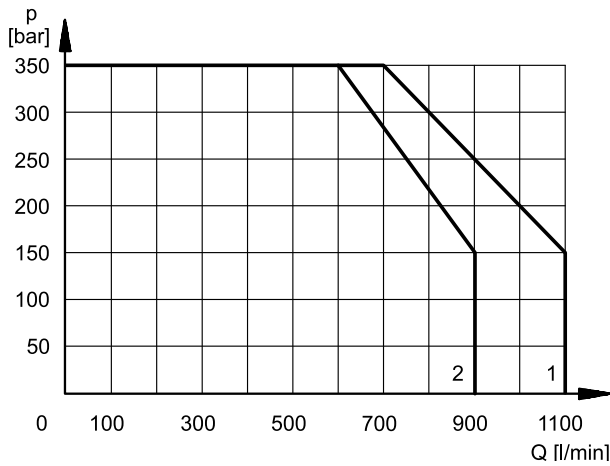

DC SOLENOID VALVE

SPOOL	CURVE	
	P→A	P→B
S1, SA1, SB1	1	1
S2, SA2, SB2	2	2
S3, SA3, SB3	1	1
S4, SA4, SB4	2	2
TA, TB	1	1
TA02, TB02	1	1
RK	1	1

NOTE: Limits showed for S1, S3, TA / TB and RK spools are determined by the value of the piloting pressure (10 bar).

7.1 - DSP11

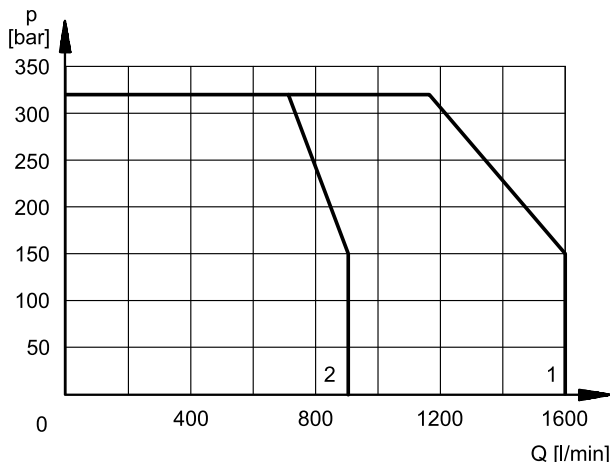

8 - ELECTRICAL FEATURES

8.1 - Solenoids

These are essentially made up of two parts: tube and coil. The tube is threaded into the valve body and includes the armature that moves immersed in oil, without wear. The inner part, in contact with the oil in the return line, ensures heat dissipation.

The coil is fastened to the tube by a threaded ring, and can be rotated 360°, to suit the available space.

NOTE 1: In order to further reduce the emissions, use of type H connectors is recommended. These prevent voltage peaks on opening of the coil supply electrical circuit (see cat. 49 000).

NOTE 2: The IP65 protection degree is guaranteed only with the connector correctly connected and installed.

VOLTAGE SUPPLY FLUCTUATION	± 10% Vnom
MAX SWITCH ON FREQUENCY	6.000 ins/hr
DUTY CYCLE	100%
ELECTROMAGNETIC COMPATIBILITY (EMC) (NOTE 1)	In compliance with 2014/30/EU
LOW VOLTAGE	In compliance with 2014/35/EU
CLASS OF PROTECTION Atmospheric agents (IEC 60529) Coil insulation (VDE 0580) Impregnation: DC valve AC valve	IP 65 (NOTE 2) class H class F class H

8.2 - Current and absorbed power for DC solenoid valve

The table shows current and power consumption values of the DC coils.

Using connectors type "D" (see cat. 49 000) with embedded bridge rectifier it is possible to feed DC coils (starting from 48V voltage) with alternating current (50 or 60 Hz), considering a reduction of the operating limits by 5 ÷ 10% approx.

(values ± 10%)

	Resistance at 20°C [Ω]	Current consumption [A]	Power consumption [W]	Coil code
				K1
D12	4.4	2.72	32.7	1903080
D24	18.6	1.29	31	1903081
D48	78.6	0.61	29.5	1903083
D110	436	0.26	28.2	1903464
D220	1758	0.13	28.2	1903465

8.3 - Current and absorbed power for AC solenoid valve

The table shows current and power consumption values at inrush and at holding, relevant to the different coil types for AC current.

(values ± 5%)

Suffix	Nominal Voltage [V]	Freq. [Hz]	Resistance at 20°C [Ω]	Current consumption at inrush [A]	Current consumption at holding [A]	Power consumption at inrush [VA]	Power consumption at holding [VA]	Coil Code K1
A24	24	50	1,69	5,81	1,32	139	32	1902830
A48	48		6,02	3,78	0,86	182	41	1902831
A110	110V-50Hz 120V-60Hz	50/60	33	1,76	0,40	194	44	1902832
				1,54	0,35	185	42	
A230	230V-50Hz 240V-60Hz		135	0,92	0,21	213	48	1902833
				0,79	0,18	190	43	
F110	110	60	28,5	1,45	0,33	160	36	1902834
F220	220		103	0,92	0,21	203	46	1902835

9 - ELECTRIC CONNECTORS

Solenoid valves are delivered without connectors. Connectors can be ordered separately. See catalogue 49 000.

10 - MAX PRESSURES

PRESSURES [bar]	DSP10	DSP10H	DSC10	DSC10H	DSP11	DSC11
Max pressure in P, A, B ports	350	420	350	420	320	320
Max pressure in T line with external drain	300	350	300	350	250	250
Max pressure in T line with internal drain	210 (DC) 160 (AC)	210 (DC) 160 (AC)	-	-	210 (DC) 160 (AC)	-
Max pressure in Y line with external drain	210 (DC) 160 (AC)	210 (DC) 160 (AC)	-	-	210 (DC) 160 (AC)	-
Minimum pilot supply pressure:	5 ÷ 12 (NOTE 1)					
Maximum pilot supply pressure (NOTE 2)	280	350	280	350	280	320

NOTE 1: The valve needs a difference of at least +10 bar between the pilot pressure and the discharge/drainage pressure in order to work correctly.

NOTE 2: If the working pressure is higher than these rated limits, then provide an external pilot line with p_{max} within the rated limits and purchase the valve with E type pilot supply.

For the valves with electro-hydraulic actuation (DSP), if the external pilot line is not possible, you must opt for the version with Z type pilot supply (see point 11), with maximum inlet pressure in P according to the values indicated in the table.

11 - PILOT AND DRAIN

The valves with electro-hydraulic actuation (DSP) are available with both pilot supply and drain internal or external. The version with external drain allows a higher back pressure on the return line.

The pilot supply Z type consists of an arrangement with internal piloting and 30 bar supply pressure for the pilot stage by means of a fixed adjustment pressure reducing valve .

The valves with hydraulic actuation (DSC) are available with external pilot supply and external drain only.

NOTE: The pilot supply and drainage configuration must be chosen when ordering. Subsequent modification is only permitted by authorized experienced operators or at the factory.

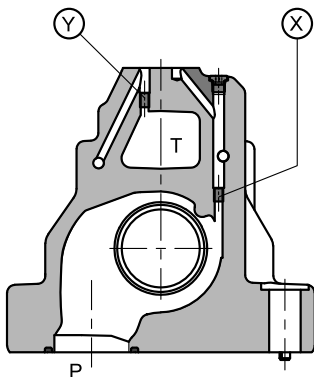

X: plug M6x8 for external pilot
Y: plug M6x8 for external drain

TYPE OF VALVE		Plug assembly	
		X	Y
IE	internal pilot and external drain	NO	YES
II	internal pilot and internal drain	NO	NO
EE	external pilot and external drain	YES	YES
EI	external pilot and internal drain	YES	NO

12 - OVERALL AND MOUNTING DIMENSIONS FOR DSP10 AND DSP11

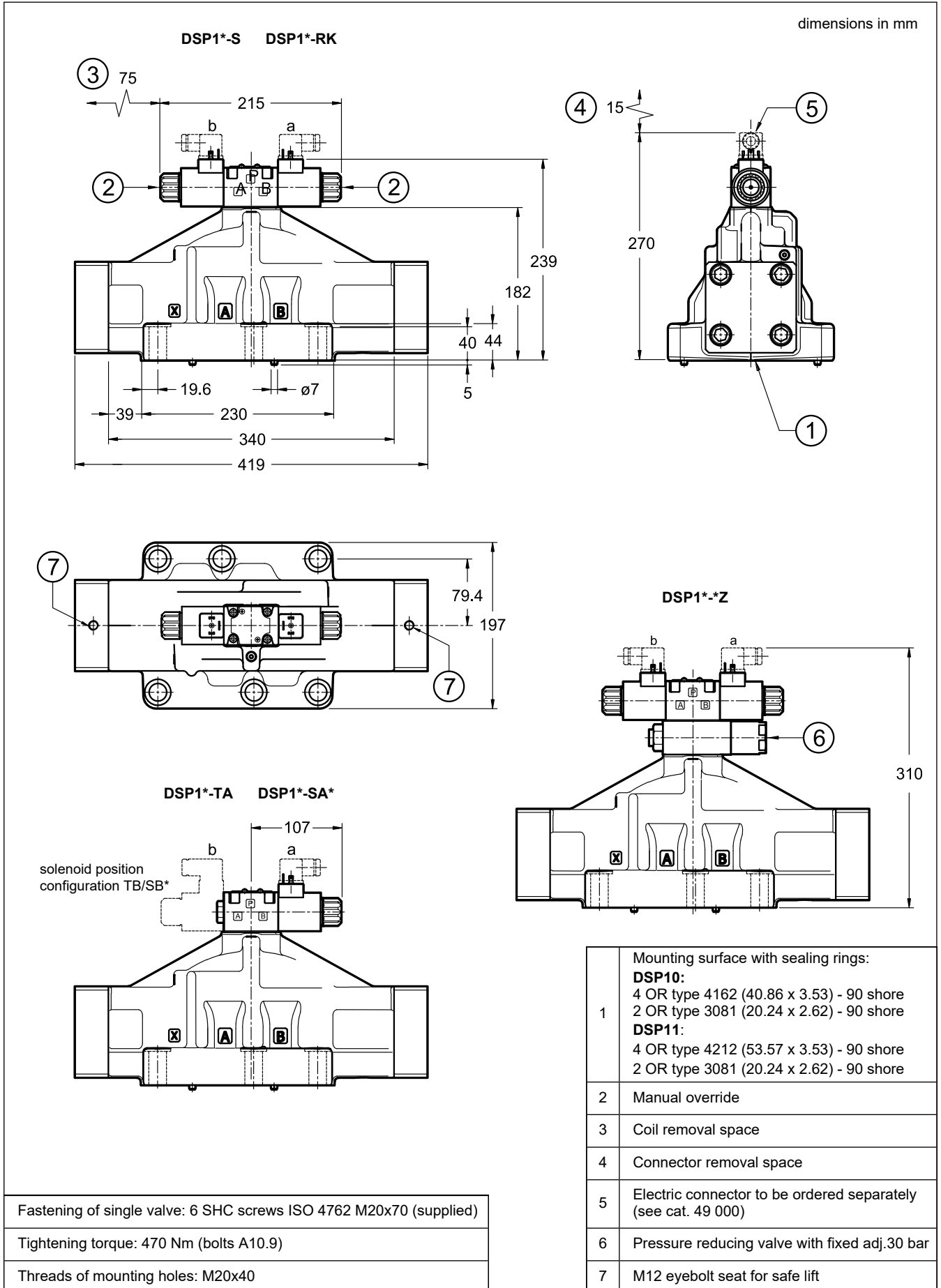

13 - OVERALL AND MOUNTING DIMENSIONS FOR DSC10 AND DSC11

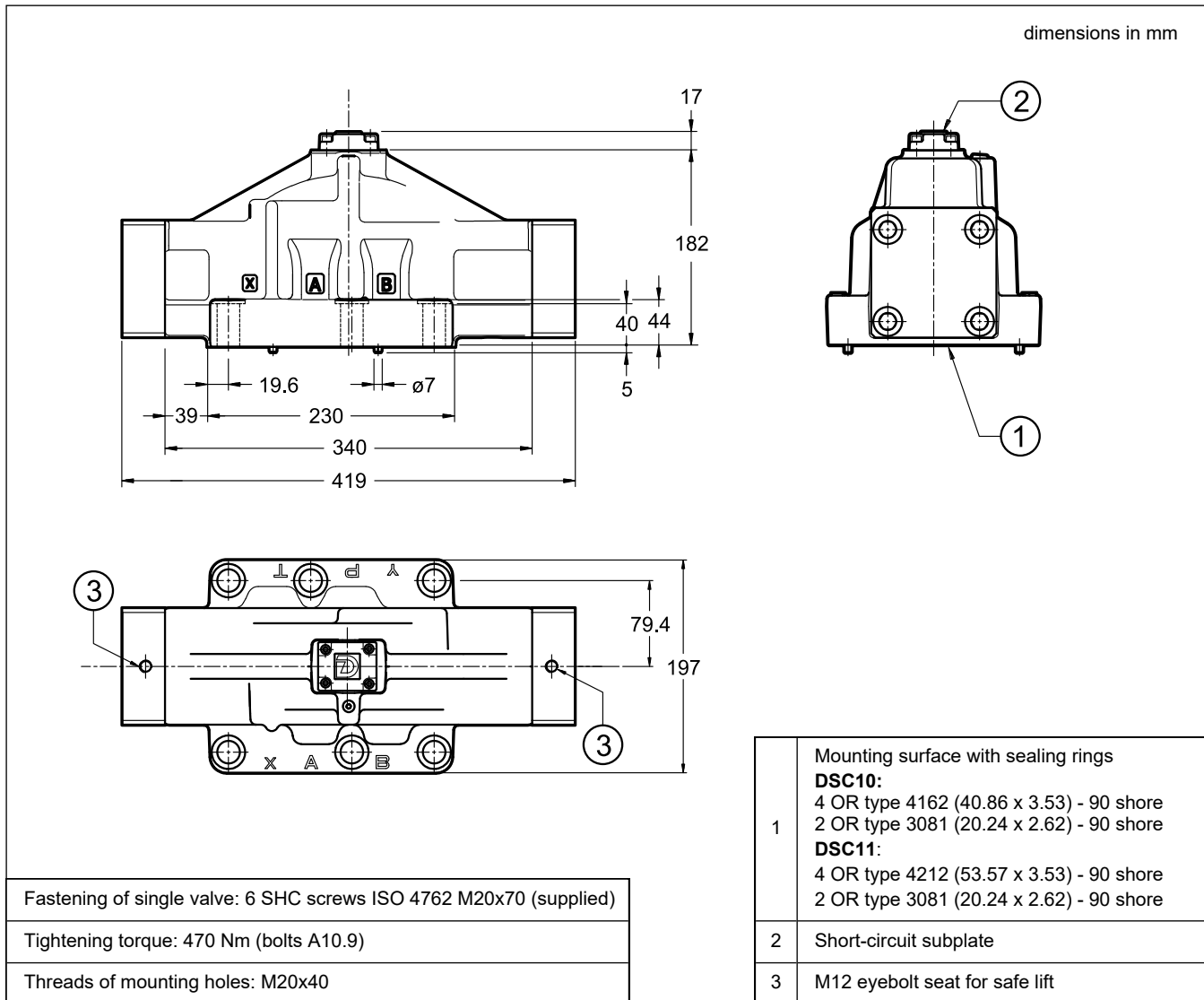

14 - MOUNTING INTERFACES

DS*10

ISO 4401-10-09-0-05
(CETOP 4.2-4-10-350)

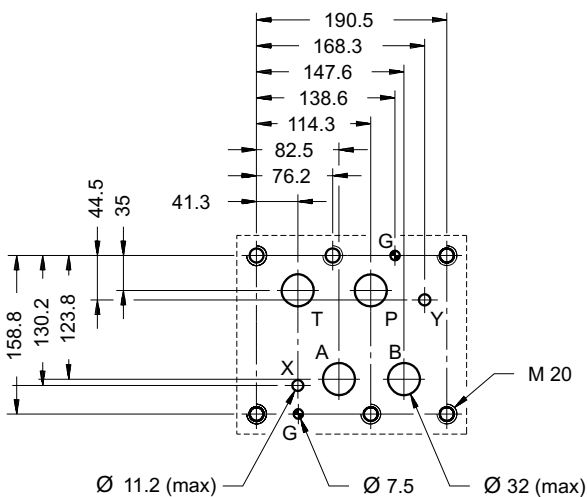

DS*11

ISO 4401-10-09-0-05
(CETOP 4.2-4-10-320)
deviating from standard:
P, T, A, B ports Ø48

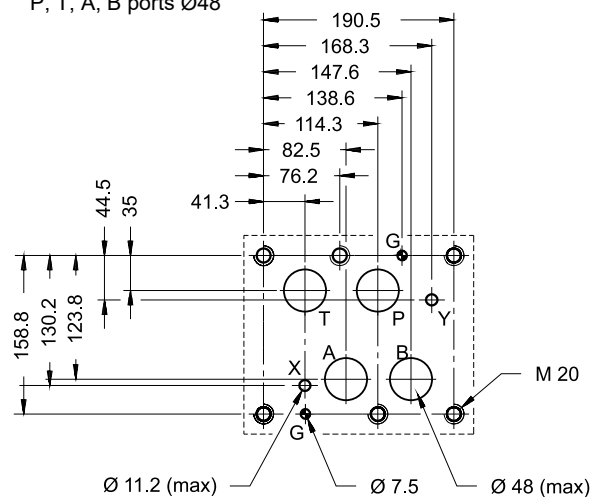

15 - OPTIONS

15.1 - Control of the main spool stroke: C

Stroke control for the main spool is possible by means of special side covers so as to vary the maximum clearance opening.

This solution allows control of the flow rate from the pump to the actuator and from the actuator to the outlet, obtaining a double adjustable control on the actuator.

Add the letter **C** in the identification code to order this version (see point 1).

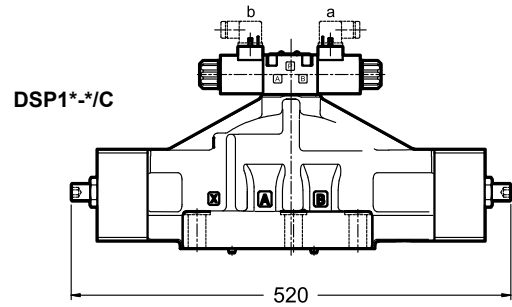

15.2 - Control of the main spool shifting speed: D

By placing a double flow control valve (QTM3 type) between the pilot solenoid valve and the main stage, the pilot supply flow can be adjusted and therefore the changeover smoothness can be varied.

Add the letter **D** in the identification code to order this version (see point 1).

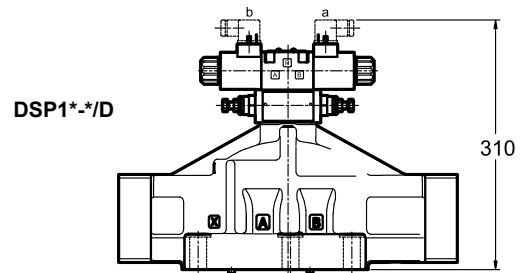

15.3 - Subplate with throttle on line P

It is possible to introduce a subplate with a restrictor of $\varnothing 1.5$ on line P between the pilot solenoid valve and the main stage.

Add **P15** in the identification code to order this version (see point 1).

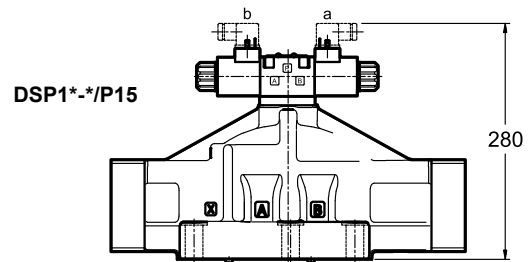

16 - MANUAL OVERRIDE

Whenever the solenoid valve installation may involve exposure to atmospheric agents or use in tropical climates, a boot protected manual override is recommended.

Add **/CM** at the end of the identification code to order this version (see point 1).

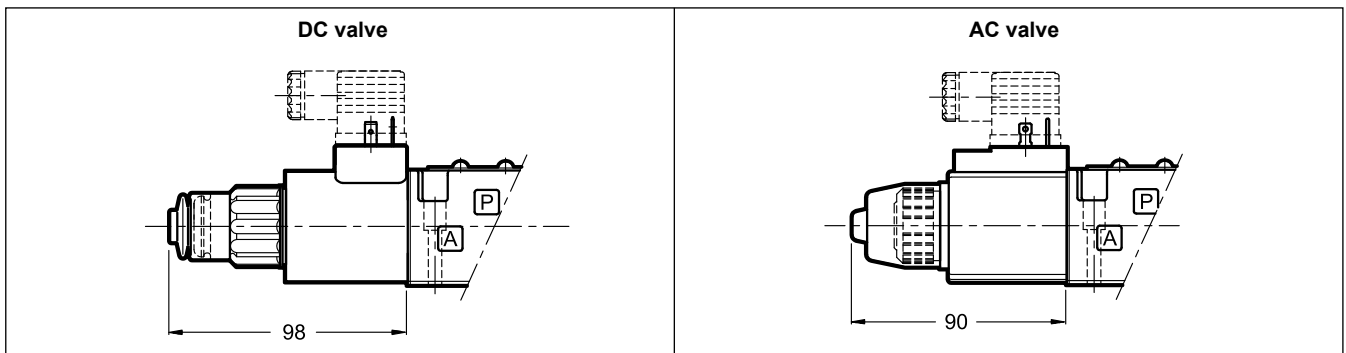

17 - INSTALLATION

Configurations with centering and recall springs can be mounted in any position; type RK valves - without springs and with mechanical detent - must be mounted with the longitudinal axis horizontal.

Valve fastening takes place by means of screws or tie rods, laying the valve on a lapped surface, with values of planarity and smoothness that are equal to or better than those indicated in the drawing.

If the minimum values of planarity or smoothness are not met, fluid leakages between valve and mounting surface can easily occur.

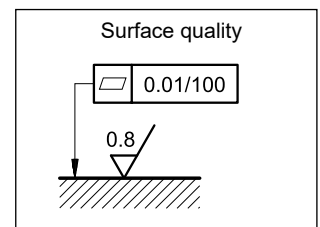



DSP1*

DUPLOMATIC
MOTION SOLUTIONS
*a member of **DAIKIN** group*

DUPLOMATIC MS Spa

via Mario Re Depaolini, 24 | 20015 Parabiago (MI) | Italy

T +39 0331 895111 | E vendite.ita@duplomatic.com | sales.exp@duplomatic.com
duplomaticmotionsolutions.com