



LOGIC ELEMENTS

LC* CARTRIDGE VALVES
ISO 7368 - DIN 24342

LP* COVERS

LCM* MONITORED LOGIC EL.

ND 16 - 25 - 32 - 40 - 50 - 63

p max **420** bar

Q max (see table of performances)

OPERATING PRINCIPLE

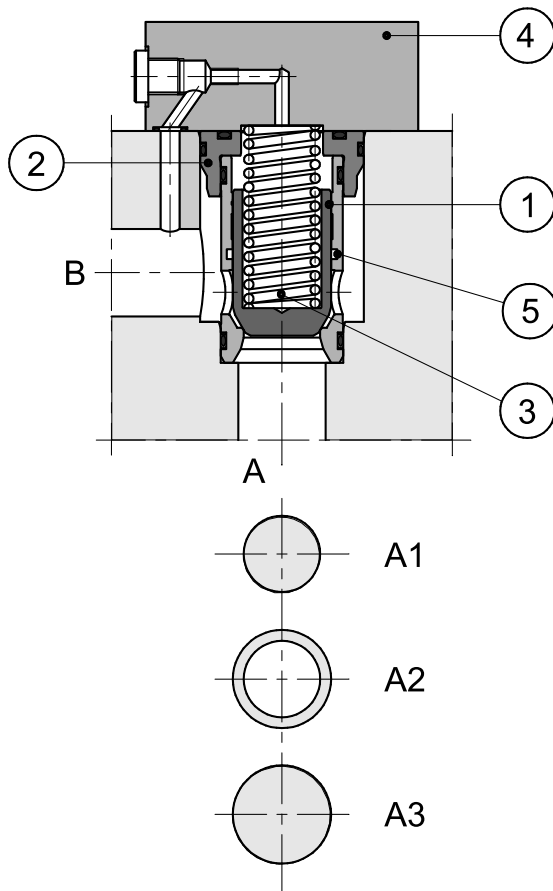

— Logic elements are cartridge valves suitable for installation in blocks or manifolds. They are available in five different sizes: ND 16 - 25 - 32 - 40 - 50 - 63.

— They are designed to perform complex hydraulic circuits, using functional compact blocks, with high flow rates and low pressure drops.

— They are made of a cartridge valve with ISO 7368 / DIN 24342 cavity bore and a control cover (4). The cover includes the cartridge valves pilot lines; some versions are designed for the installation of ISO 4401-03 valves, to realise different control functions (see paragraph 8 for diagrams and function descriptions). A low leakage version, obtained inserting a seal into the seat no. 5, is also available.

— The cartridge valves are composed of a jacket (2), a poppet (1), and a closing spring (3). The poppet can either be standard (S) or with a damping nose (D), suitable for a smooth flow control during the valve opening and closing phases.

— Two types of cartridge valves are available:

- **Q** type: used for flow and directional control and as a check valve.

The areas involved are:

A1 - corresponding to the seat diameter area, considered as reference area = 1

A3 - corresponding to the jacket internal diameter area.

A2 - corresponding to the difference between A3 - A1

The area ratio A1/A3 is 1/1,66.

The valve opens when the pressure, acting either on area A1 (flow from A to B) or on area A2 (flow from B to A), is higher than the pressure acting on area A3 (added to the spring load value).

- **P** type: used for pressure control.

In this case the areas A1 and A3 are equivalent (area ratio 1:1) and the valve enables the flow direction from A to B only.

— **LCM*** are logic elements with spool position monitoring used for directional control, flow control, piloting and as check valve. They are certified by TÜV.

Available sizes are ND 16, 25, 32, 40 and 50.

1 - IDENTIFICATION CODE FOR CARTRIDGE VALVES

L	C		-			/		N	/	
----------	----------	--	---	--	--	---	--	----------	---	--

Cartridge valve

Shutter type:
(area ratio A1 / A3):
QS = flow rate control (1:1,66)
QD = flow rate control with damping nose (1:1,66)
PS = pressure control (1:1)

LL = Low leakage version, with seal between C and B.
Not available for QS0.5
Omit if not required.

Seals:
NBR seals for mineral oil

20 - for ND 16, 25, 32, 40 and 50
21 - for ND 63
 (the overall and mounting dimensions remain unchanged from 20 to 29)

Nominal cracking pressure on section A1:
Verify the versions availability in the table below. Other cracking pressure values are available on request.

0.5 = 0,5 bar
1 = 1 bar
2 = 2 bar
4 = 4 bar

AVAILABLE NOMINAL SIZES						VERSIONS	SYMBOL
16 ND16	25 ND25	32 ND32	40 ND40	50 ND50	63 ND63		
x	x	x	x	x		QS0.5	
x	x	x	x	x	x	QS2	
x	x	x	x	x		QD4	
					x	PS1	
x	x	x	x	x		PS2	

2 - HYDRAULIC FLUIDS

Use mineral oil-based hydraulic fluids HL or HM type, according to ISO 6743-4. For these fluids, use NBR seals. For the use of other kinds of fluid such as HFA, HFB, HFC, please consult our technical department.

Using fluids at temperatures higher than 80 °C causes a faster degradation of the fluid and of the seals characteristics.

The fluid must be preserved in its physical and chemical characteristics.

3 - TECHNICAL CHARACTERISTICS

(cartridge valve with control cover)

Max operating pressure LC cartridge valve	bar	420
Max operating pressure limit of covers type DP*, DPE*, DF1, DF2, LCM	bar	350
Max operating pressure with distributor installed on cover	See technical characteristics of the distributor	
Ambient temperature range	°C	-20 / +50
Fluid temperature range	°C	-20 / +80
Fluid viscosity range	cSt	10 ÷ 400
Fluid contamination degree	According to ISO 4406:1999 class 20/18/15	
Recommended viscosity	cSt	25

3.1 - Cartridge valves type Q performances

(flow control function)

			NOMINAL SIZE						
			16	25	32	40	50	63	
Area A1	cm ²		1,54	3	6	8,76	14,8	24,6	
Area A2	cm ²		1	2	4	5,76	9,7	16,1	
Area A3	cm ²		2,54	4,9	10	14,3	24,3	40,7	
Version S:	opening stroke h	cm	0,8	1	1,25	1,6	1,8	2,3	
	opening volume	cm ³	2,03	4,9	12,5	22,88	43,74	96,26	
	max recommended flow	l/min	250	500	900	1300	2000	3000	
Version D:	opening stroke h	cm	0,8	1,15	1,5	1,8	2,2	2,7	
	opening volume	cm ³	2,03	5,63	15	25,74	53,46	110	
	max recommended flow	l/min	200	450	800	1100	1700	2700	
Cracking pressure	A→B	spring 0,5	bar	0,5	0,5	0,5	0,5	0,5	-
		spring 2		2	2	2	2	2	2
		spring 4		4	4	4	4	4	-
	B→A	spring 0,5		0,9	1,1	0,7	0,76	0,8	-
		spring 2		3,1	3	3,1	3	3,2	3,2
		spring 4		6,15	5,9	5,4	5,9	5,9	-
Mass	Kg		0,25	0,5	1,1	1,9	3,9	7,8	

3.2 - Cartridge valves type P performances

(pressure control function)

			NOMINAL SIZE					
			16	25	32	40	50	63
Area A1 = Area A3	cm ²		2,54	4,9	10	14,4	24,3	40,7
Version S:	max recommended flow	l/min	200	400	900	1000	1500	2500
Cracking pressure	spring 1	bar	-	-	-	-	-	1
	spring 2		2	2	2	2	2	-
Mass	Kg		0,25	0,5	1,1	1,9	3,9	7,8

4 - CHARACTERISTIC CURVES

(values obtained with viscosity 36 cSt at 50°C)

4.1 - LC*- QS flow control function and LC*-PS pressure control function

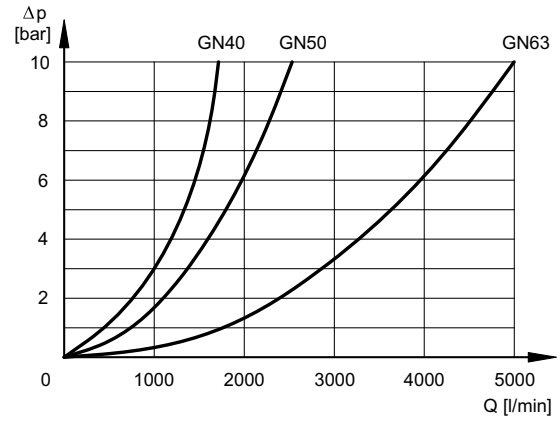
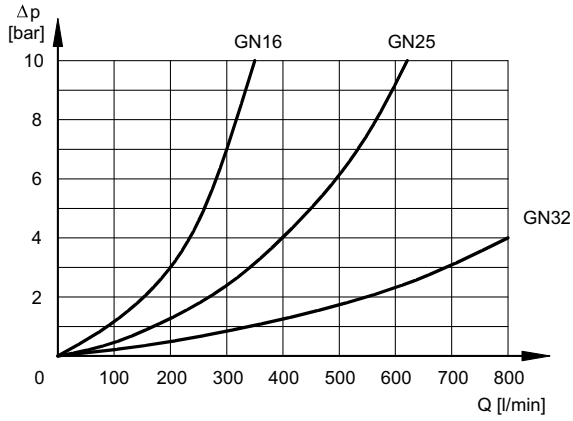

4.2 - Flow control function with damping nose LC*- QD

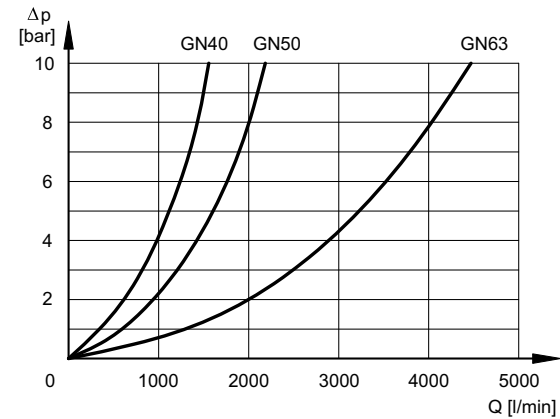
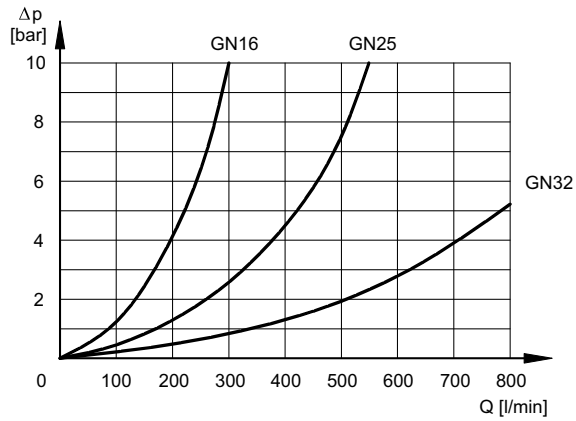

5 - LC CARTRIDGE VALVES SEAT DIMENSIONS ACCORDING TO ISO 7368 / DIN 24342

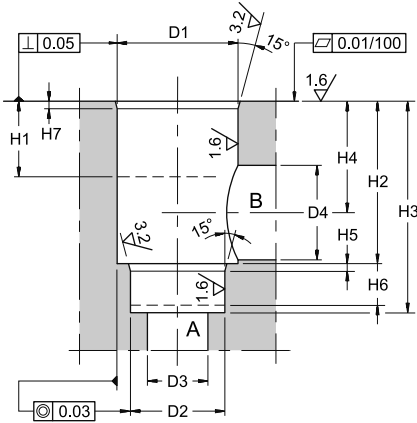

	LC CARTRIDGE VALVES NOMINAL SIZE					
	16	25	32	40	50	63
ØD1 ^{H7}	32	45	60	75	90	120
ØD2 ^{H7}	25	34	45	55	68	90
ØD3 max	16	25	32	40	50	63
ØD4	16	25	32	40	50	63
ØD4 max	25	32	40	50	63	80
H1 min	20	30	30	30	35	40
H2 ± 0,1	43	58	70	87	100	130
H3 ^{+ 0,1} ₀	56	72	85	105	122	155
H4 referred to diameter ØD4	34	44	52	64	72	95
H4 referred to diameter ØD4 max	29,5	40,5	48	59	65,5	86,5
H5	2	2,5	2,5	3	3	4
H6 min	11	12	13	15	17	20
H7	2	2,5	2,5	3	4	4

6 - LP CONTROL COVERS INTERFACE DIMENSIONS ACCORDING TO ISO 7368 / DIN 24342

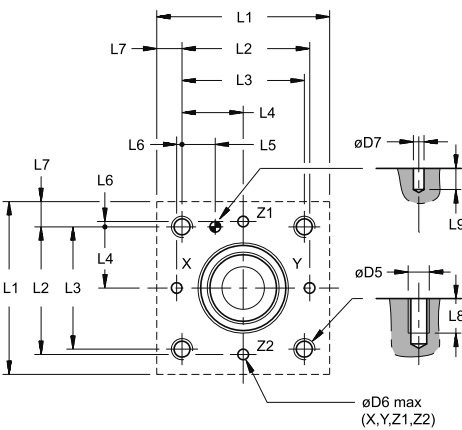

	LP CONTROL COVERS NOMINAL SIZE					
	16	25	32	40	50	63
ØD5	M8	M12	M16	M20	M20	M30
ØD6 max	4	6	8	10	10	12
ØD7 ^{H13}	4	6	6	6	8	8
L1	*	85	102	125	140	180
L2 ± 0,1	48	62	76	92,5	108	137,5
L3 ± 0,1	46	58	70	85	100	125
L4 ± 0,1	23	29	35	42,5	50	62,5
L5 ± 0,1	12,5	13	18	19,5	20	24,5
L6 ± 0,1	2	4	6	7,5	8	12,5
L7	*	13,5	16	20	20	27,5
L8 min	15	20	28	35	35	52
L9 min	8	8	8	8	8	8

* = cover with special dimensions (see par. 10.2 + 10.7)

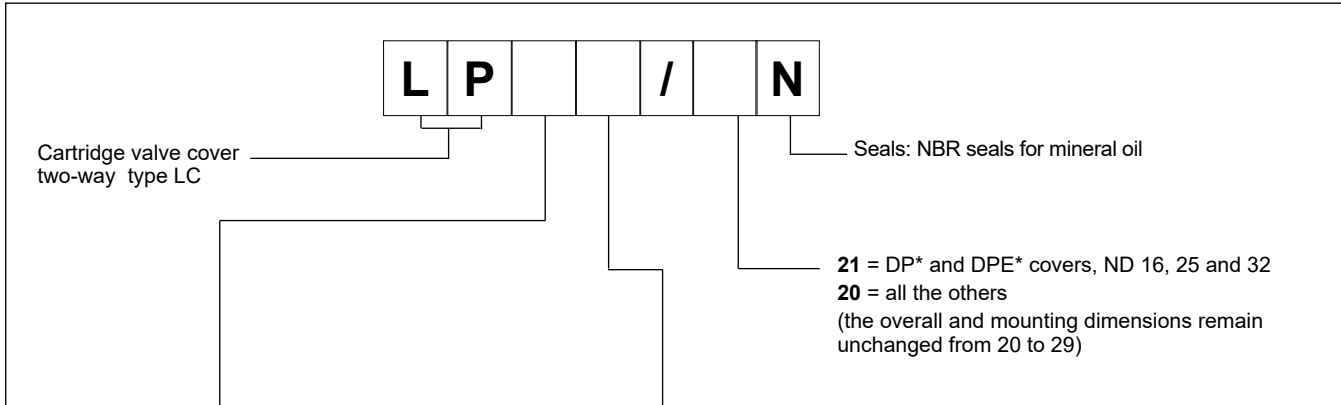
7 - COVERS IDENTIFICATION CODE

AVAILABLE NOMINAL SIZES						COVER NAME	SYMBOL	DIAGRAM PARAGRAPH	OVERALL DIMENSIONS PARAGRAPH
16 ND16	25 ND25	32 ND32	40 ND40	50 ND50	63 ND63				
x	x	x			x	R		8.1	10.1
x	x	x	x	x	x	D		8.2	10.2
x	x	x	x			DZ		8.3	10.3
x	x	x	x	x		DF1		8.4	10.4
x	x	x	x	x		DF2		8.5	10.5
x	x	x	x	x	x	Q		8.6	10.6
x	x	x	x	x	x	DP*		8.7	10.7
x	x	x	x	x		DPE*		8.8	10.7

8 - FUNCTIONAL DIAGRAMS

8.1 - R cover for directional control and check valve function with external pilot X

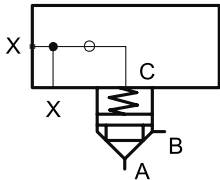
Functional diagrams	Description
	<p>Piloting of the cartridge valve through the X port, available on the mounting surface or with pipe connection 1/4" BSP.</p> <p>For ND 40 and ND 50 sizes, the external piloting function can be realised by using control cover type D, with blanking plate code 1950751 (to be ordered separately).</p>

8.2 - D cover for directional control and check valve function

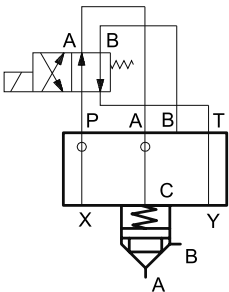
Functional diagrams	Description
	<p>Piloting of the cartridge valve by means of solenoid valve type DS3-TA (to be ordered separately - see catalogue 41 150)</p> <ul style="list-style-type: none"> - solenoid valve OFF = A ↔ B intercepted flow - solenoid valve ON = A ↔ B free flow

8.3 - DZ cover for directional control with possibility to pilot other cartridges in line

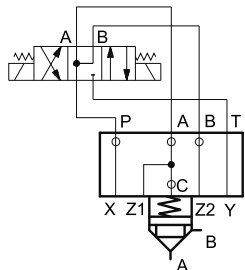
Functional diagrams	Description
	<p>The DZ cover enables the piloting of its cartridge valves and also of other valves connected to Z1 and Z2 pilot lines.</p> <p>The solenoid valve type DS3-S10 must be ordered separately (see catalogue 41 150).</p>

8.4 - DF1 cover for directional control and check function with double pilot line

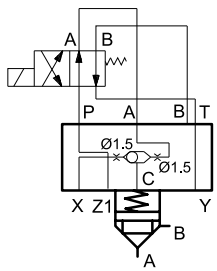
Functional diagrams	Description
	<p>The DF1 cover gives the possibility of a double pilot line through X and Z1 ports.</p> <p>The solenoid valve type DS3-TA must be ordered separately (see catalogue 41 150).</p> <ul style="list-style-type: none"> - solenoid valve OFF = A ↔ B intercepted flow - solenoid valve ON = A → B free flow, B → A intercepted (if pilot line X is connected with B and if Z1 is connected with A).

8.5 - DF2 cover for directional control and check function with priority piloting from two external lines

Functional diagrams	Description
	<p>The cartridge valve can be simultaneously piloted from X and Z1 lines.</p> <p>The shuttle valve, integrated in the cover, enables the automatic selection of the pilot line which has the higher pressure (priority line).</p> <p>The solenoid valve type DS3-TA must be ordered separately (see catalogue 41 150).</p> <ul style="list-style-type: none"> - solenoid valve OFF = A ↔ B intercepted flow - solenoid valve ON = A ↔ B free flow

8.6 - Q cover for flow control function

Functional diagrams	Description
	<p>Flow control function by means of cover with stroke limiter.</p> <p>For a better flow control and to avoid the wear of the valve seat, this cover is normally used with a QD4 cartridge type.</p>

8.7 - DP* cover for pressure control function

Functional diagrams	Description
	<p>Pressure control function with a built-in relief valve.</p> <ul style="list-style-type: none"> - max. adjustment pressure DP4 = 140 bar - DP6 = 350 bar <p>The top blanking plate code 1950591 must be ordered separately.</p>
	<p>Pressure control function with electrical unloading by means of DS3-SA2 solenoid valve (to be ordered separately - see catalogue 41 150).</p> <ul style="list-style-type: none"> - solenoid valve OFF = unloading at minimum pressure - solenoid valve ON = pressure controlled by the built-in relief valve.
	<p>Pressure control function with electrical unloading and two step pressure by means of the solenoid valves DS3-S2 (to be ordered separately - see catalogue 41 150), PLM3-AT*/10 (for 16, 25 and 32 sizes - to be ordered separately) and MCD*-SAT (for 40, 50 and 63 sizes to be ordered separately - see catalogue 61 200)</p> <ul style="list-style-type: none"> - solenoid valve OFF = unloading at minimum pressure - solenoid valve ON side a = pressure controlled by the relief valve integrated in the cover - solenoid valve ON side b = pressure controlled by the relief valve (PLM3 or MCD*)

	<p>Pressure control function with electrical control and three steps pressure by means of the solenoid valves DS3-S3 (to be ordered separately - see catalogue 41 150), PLM3-DT/10 (for 16 - 25 and 32 sizes - to be ordered separately) and MCD*-DT/51 (for 40 and 50 sizes - to be ordered separately - see catalogue 61 200)</p> <ul style="list-style-type: none"> - solenoid valve OFF = pressure controlled by the cover relief valve. - solenoid valve ON side a = pressure controlled by the relief valve on side b. - solenoid valve ON side b = pressure controlled by the relief valve on side a.
--	--

8.8 - DPE* cover for pressure control function

Functional diagram	Description
	<p>Pressure control function by means of PDE3 proportional valve (to be ordered separately, see catalogue 81 211).</p> <ul style="list-style-type: none"> - max. adjustment pressure DPE4 = 140 bar - DPE6 = 350 bar - proportional valve OFF = unloading at minimum pressure - proportional valve ON = proportional control of pressure

9 - TIGHTENING TORQUES FOR COVERS

Tightening torques in the chart below were calculated for screws with class A10.9, applying a total friction coefficient $\mu = 0,15$.

We recommend these tightening torques for screws suitable for the specified friction coefficient and for tightenings done with manual torque wrench.

Size	Screws type (no. 4 pcs.)	Tightening torque ($\pm 10\%$) [Nm]
16	M8	32
25	M12	110
32	M16	270
40	M20	530
50	M20	530
63	M30	1900

NOTE: Screws characteristics for each type of cover are described in paragraph 10.

10 - OVERALL AND MOUNTING DIMENSIONS FOR CONTROL COVERS

10.1 - R type covers

dimensions in mm

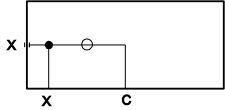

LP16R
LP25R
LP32R
LP63R

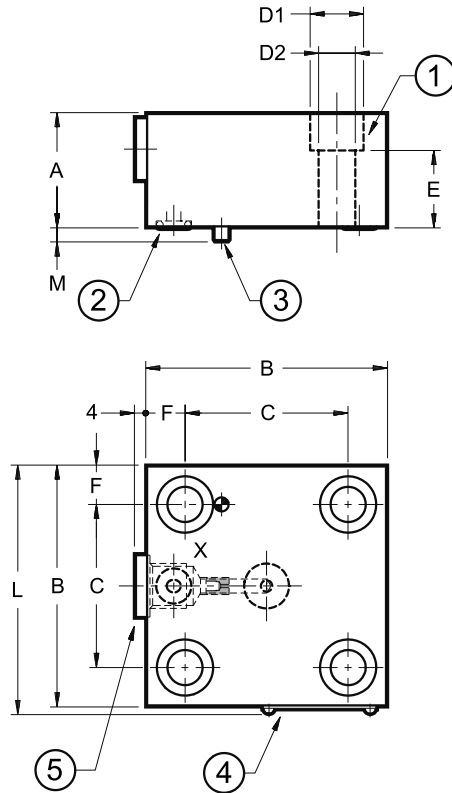

	NOMINAL SIZE			
	16	25	32	63
A	30	30	40	70
B	65	85	102	180
C	46	58	70	125
D1	13,5	19	25	46
D2	8,5	13	17	31
E	19	17	22	35
F	9,5	13,5	16	27,5
L	67,5	87,5	104,5	182,5
M	4	5	5	5

ports ready for restrictors	port X			
restrictors	M6x8			M10x10
Mass [kg]	1,20	2,30	4,00	17,5

1	N. 4 fastening bolts (NOTE): 16 = M8x30 25 = M12x35 32 = M16x45 63 = M30x80
2	N. 1 sealing ring 90 Shore: 16 = OR type 2025 (6.07x1.78) 25 = OR type 2037 (9.25x1.78) 32 = OR type 2043 (10.82x1.78) 63 = OR type 3062 (15.54x2.62)
3	Locating pin: 16 = Ø3x10 25 = Ø5x14 32 = Ø5x14 63 = Ø6x14
4	Identification label
5	Plug X: 1/4" BSP

NOTE: Fastening bolts class 10.9 ISO 4762 are recommended for the installation of the cover (to be ordered separately).
Tightening torques at par. 9

10.2 - Covers type D

dimensions in mm

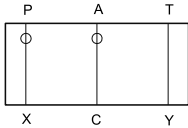

LP16D
LP25D
LP32D
LP40D
LP50D
LP63D

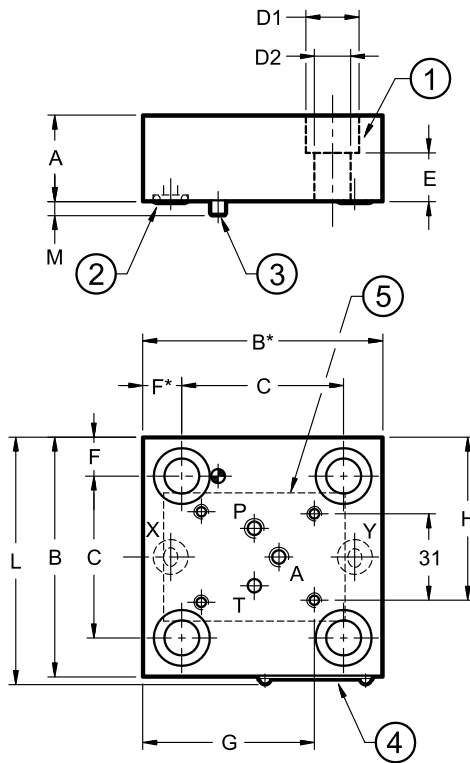

	NOMINAL SIZE					
	16	25	32	40	50	63
A	30	30	40	40	50	70
B	65	85	102	125	140	180
B*	75	85	102	125	140	180
C	46	58	70	85	100	125
D1	13,5	19	25	31	31	46
D2	8,9	13	17	21	21	31
E	19	17	22	30	30	35
F	9,5	13,5	16	20	20	27,5
F*	19,5	13,5	16	20	20	27,5
G	52	60,2	68,7	73,2	82,7	111,5
H	48	58	66,5	78	85,5	105,5
L	67,5	87,5	104,5	127,5	142,5	182,5
M	4	5	5	5	5	7

ports ready for restrictors	P, A					
restrictors	M6x8					M8x8
Mass [kg]	1,20	2,30	4,00	4,80	7,6	17,5

1	N. 4 fastening bolts (NOTE): 16 = M8x30 25 = M12x35 32 = M16x45 40 = M20x50 50 = M20x60 63 = M30x80
2	n° 2 sealing rings 90 Shore : 16 = OR type 2025 (6.07x1.78) 25 = OR type 2037 (9.25x1.78) 32 = OR type 2043 (10.82x1.78) 40 = OR type 2050 (12.42x1.78) 50 = OR type 2050 (12.42x1.78) 63 = OR type 3062 (15.54x2.62)
3	Locating pin: 16 = Ø3x10 25 = Ø5x14 32 = Ø5x14 40 = Ø5x14 50 = Ø6x14 63 = Ø6x14
4	Identification label
5	Mounting surface ISO 4401-03 (CETOP 4.2-4-03-350)

NOTE: Fastening bolts class 10.9 ISO 4762 are recommended for the installation of the cover (to be ordered separately).
Tightening torques at par. 9

10.3 - Covers type DZ

dimensions in mm

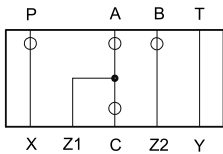

LP16DZ
LP25DZ
LP32DZ
LP40DZ

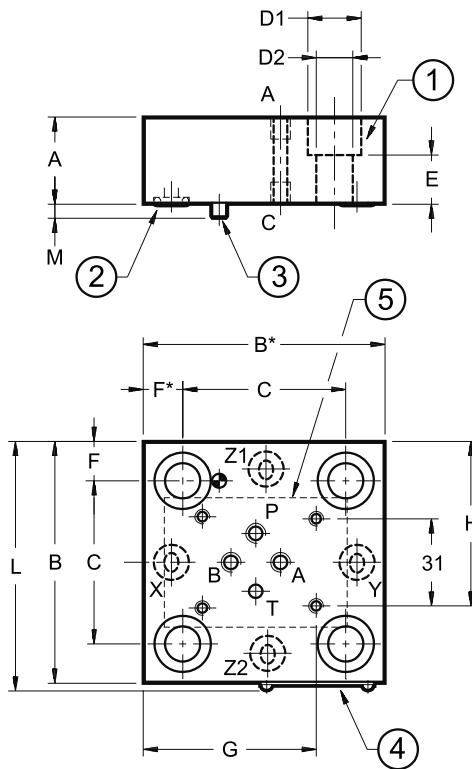

	NOMINAL SIZE			
	16	25	32	40
A	30	30	40	40
B	65	85	102	125
B*	75	85	102	125
C	46	58	70	85
D1	13,5	19	25	31
D2	8,9	13	17	21
E	19	17	22	20
F	9,5	13,5	16	20
F*	19,5	13,5	16	20
G	52	60,2	66,2	73,2
H	48	58	66,5	78
L	67,5	87,5	104,5	127,5
M	4	5	5	5

ports ready for restrictors M6x8	P, A, B, C			
Mass [kg]	1,2	2,3	2,8	4,1

1	N. 4 fastening bolts (NOTE): 16 = M8x30 25 = M12x35 32 = M16x45 40 = M20x50
2	n° 4 sealing rings 90 Shore : 16 = OR type 2025 (6.07x1.78) 25 = OR type 2037 (9.25x1.78) 32 = OR type 2043 (10.82x1.78) 40 = OR type 2050 (12.42x1.78)
3	Locating pin: 16 = Ø3x10 25 = Ø5x14 32 = Ø5x14 40 = Ø5x14
4	Identification label
5	Mounting surface ISO 4401-03 (CETOP 4.2-4-03-350)

NOTE: Fastening bolts class 10.9 ISO 4762 are recommended for the installation of the cover (to be ordered separately). Tightening torques at par. 9

10.4 - Covers type DF1

dimensions in mm

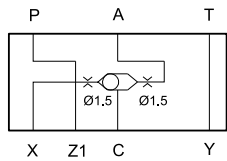

LP16DF1

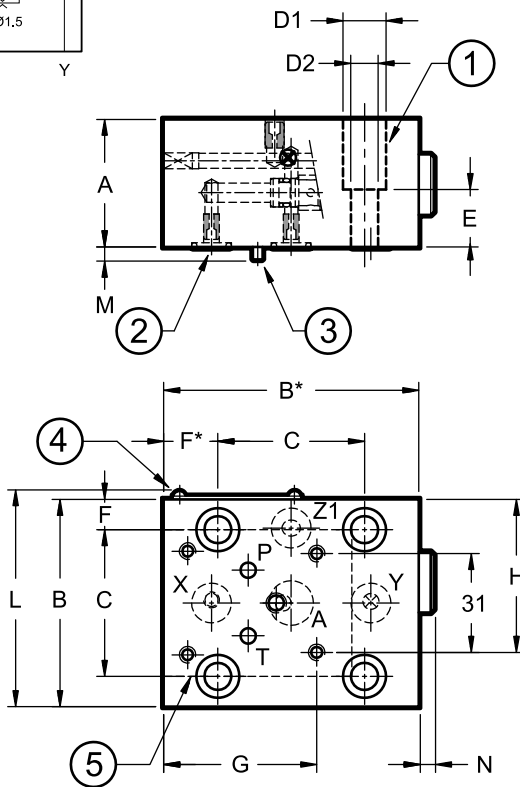

LP25DF1
LP32DF1
LP40DF1
LP50DF1

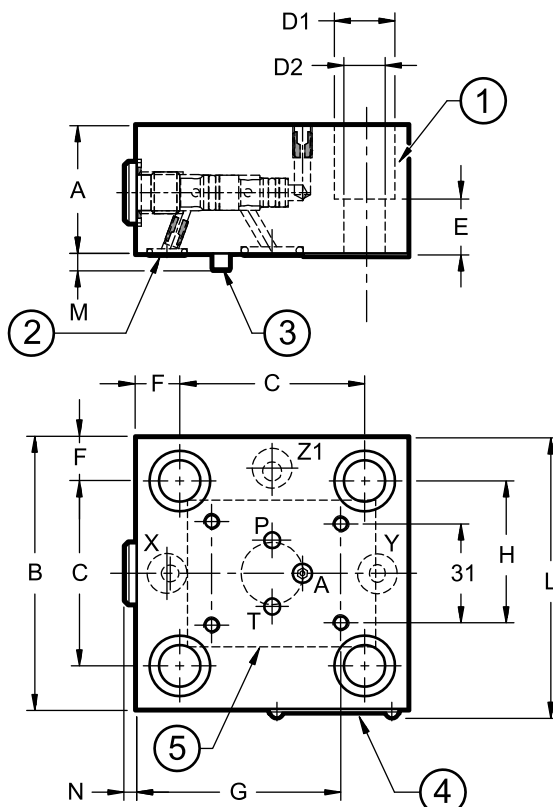

	NOMINAL SIZE				
	16	25	32	40	50
A	40	40	40	50	50
B*	80	85	102	125	140
B	65	85	102	125	140
C	46	58	70	85	100
D1	13,5	19	25	31	31
D2	8,5	13	17	21	21
E	18	17	22	30	30
F*	17	13,5	16	20	20
F	9,5	13,5	16	20	20
G	47,5	64	72,5	84	91,5
H	48	58	66,5	78	85,5
L	67,5	87,5	104,5	127,5	142,5
M	4	5	5	5	5
N	4,5	3,5	3,5	-	-

Mass [kg]	1,8	2,3	3	6,7	7,6

1	N. 4 fastening bolts (NOTE): 16 = M8x30 25 = M12x35 32 = M16x45 40 = M20x60 50 = M20x60
2	N° 3 sealing rings 90 Shore: 16 = OR type 2037 (9.25x1.78) 25 = OR type 2037 (9.25x1.78) 32 = OR type 2043 (10.82x1.78) 40 = OR type 2050 (12.42x1.78) 50 = OR type 2050 (12.42x1.78)
3	Locating pin 16 = Ø3x10 40 = Ø5x14 25 = Ø5x14 50 = Ø6x14 32 = Ø5x14
4	Identification label
5	Mounting surface ISO 4401-03 (CETOP 4.2-4-03-350)

NOTE: Fastening bolts class 10.9 ISO 4762 are recommended for the installation of the cover (to be ordered separately).
Tightening torques at par. 9

10.5 - Covers type DF2

dimensions in mm

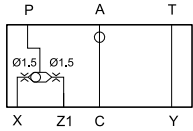

LP16DF2
 LP25DF2
 LP32DF2
 LP40DF2
 LP50DF2

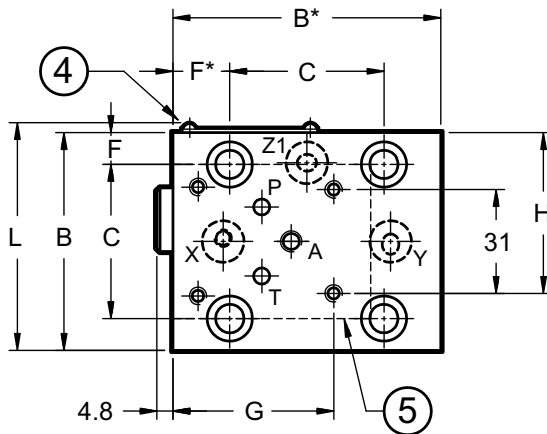
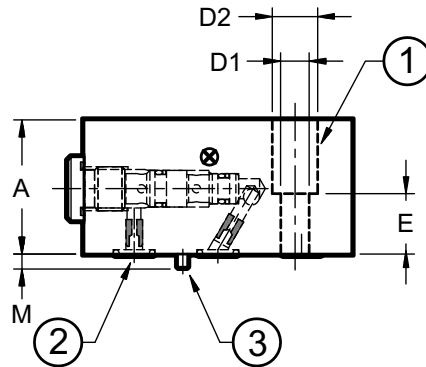

	NOMINAL SIZE			
	16	25	32	40
A	40	40	40	50
B	65	85	102	125
B*	80	85	102	125
C	46	58	70	85
D1	13,5	19	25	31
D2	8,5	13	17	21
E	18	17	22	30
F	9,5	13,5	16	20
F*	17	13,5	16	20
G	48	61	68,7	81
H	48	58	71.2	73
L	67,5	87,5	104.5	127.5
M	4	5	5	5

ports ready for restrictors M6x8	A			
Mass [kg]	1,8	2,3	3	6,7

1	N. 4 fastening bolts (NOTE): 16 = M8x30 25 = M12x35 32 = M16x45 40, 50 = M20x60
2	N° 3 sealing rings 90 Shore: 16, 25 = OR type 2037 (9.25x1.78) 32 = OR type 2043 (10.82x1.78) 40, 50 = OR type 2050 (12.42x1.78)
3	Locating pin 16 = Ø3x10 32 = Ø5x14 25 = Ø5x14 40 = Ø5x14 50 = Ø6x14
4	Identification label
5	Mounting surface ISO 4401-03 (CETOP 4.2-4-03-350)

NOTE: Fastening bolts class 10.9 ISO 4762 are recommended for the installation of the cover (to be ordered separately). Tightening torques at par. 9

10.6 - Covers type Q

dimensions in mm

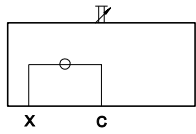

LP16Q
LP25Q
LP32Q

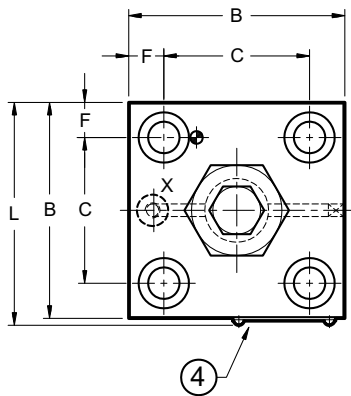
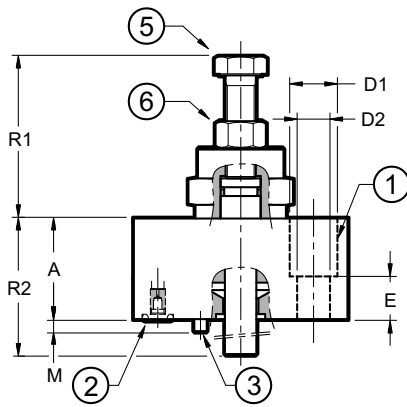

	NOMINAL SIZE					
	16	25	32	40	50	63
A	35	40	40	60	60	80
B	65	85	102	125	140	180
C	46	58	70	85	100	125
D1	13,5	19	25	31	31	46
D2	8,5	13	17	21	21	31
E	18	17	22	30	30	45
F	9,5	13,5	16	20	20	27,5
L	67,5	87,5	104,5	127,5	142,5	182,5
M	4	5	5	5	5	5
R1	55,5 ÷ 63,5	62,5 ÷ 74	58,5 ÷ 73,5	38,5 ÷ 57	44,5 ÷ 66,5	52 ÷ 81
R2	45 ÷ 51,5	45 ÷ 51,5	45 ÷ 51,5	44 ÷ 52	44 ÷ 52	165 ÷ 194

ports ready for restrictors	port X					
	M5x8	M6x8			M10x10	
Mass [kg]	1,6	3	5	8,9	11,7	18

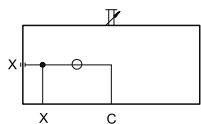

LP40Q
LP50Q
LP63Q

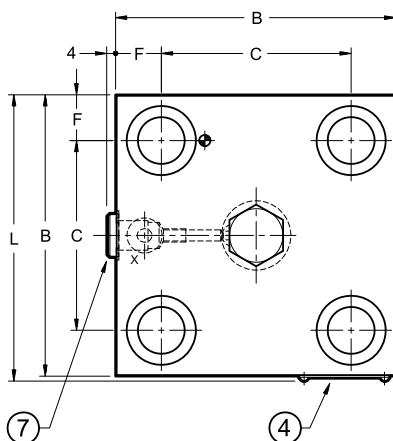
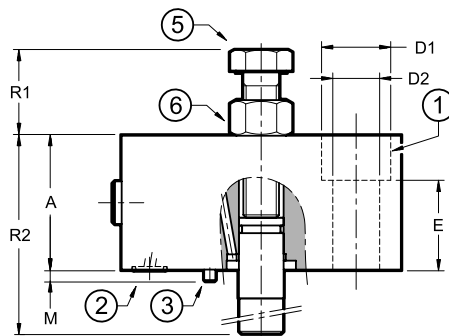

1	N. 4 fastening bolts (NOTE): 16 = M8x30 25 = M12x35 32 = M16x35 40 = M20x70 50 = M20x70 63 = M30x90
2	n° 1 sealing ring 90 Shore: 16 = OR type 2025 (6.07x1.78) 25 = OR type 2037 (9.25x1.78) 32 = OR type 2043 (10.82x1.78) 40 = OR type 2050 (12.42x1.78) 50 = OR type 2050 (12.42x1.78) 63 = OR type 3062 (15.54x2.62)
3	Locating pin: 16 = Ø3x10 25 = Ø5x14 32 = Ø5x14 40 = Ø5x14 50 = Ø6x14 63 = Ø6x14
4	Identification label
5	Stroke limiter clockwise rotation to reduce stroke 16 = 1 turn: 1,25 mm - spanner 18 25 = 1 turn: 1,25 mm - spanner 18 32 = 1 turn: 1,25 mm - spanner 18 40 = 1 turn: 2,00 mm - spanner 24 50 = 1 turn: 2,50 mm - spanner 30 63 = 1 turn: 2,00 mm - spanner 36
6	Locking nut: 16 = spanner 18 25 = spanner 18 32 = spanner 18 40 = spanner 24 50 = spanner 30 63 = spanner 36
7	Plug X: 40 = 1/4" BSP 50 = 1/4" BSP 63 = 1/4" BSP

NOTE: Fastening bolts class 10.9 ISO 4762 are recommended for the installation of the cover (to be ordered separately).
Tightening torques at par. 9

10.7 - Covers type DP* and DPE*

dimensions in mm

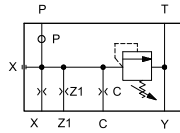
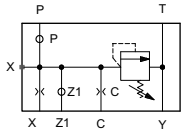

- LP16DP*
- LP25DP*
- LP32DP*
- LP40DP*
- LP50DP*
- LP63DP*

- LP16DPE*
- LP25DPE*
- LP32DPE*
- LP40DPE*
- LP50DPE*

	NOMINAL SIZE					
	16	25	32	40	50	63
A	40	40	40	50	50	70
B	65	85	102	125	140	180
B*	75	85	102	125	140	180
C	46	58	70	85	100	125
D1	13,5	19	25	31	31	46
D2	8,5	13	17	21	21	31
E	18	17	22	30	30	35
F	9,5	13,5	16	20	20	27,5
F*	19,5	13,5	16	20	20	27,5
G	52	64	72,5	84	91,5	111,5
H	48	58	66,5	78	85,5	105,5
L	67,5	87,5	104,5	127,5	142,5	182,5
M	4	5	5	5	5	5
N	22	23	22	25	25	35
R	45 + 50,5	45 + 50,5	45 + 50,5	44 + 52	44 + 52	44 + 52

Mass [kg]	1,2	2,4	4	7,4	10,5	17,5
-----------	-----	-----	---	-----	------	------

DP* restrictors

	M5x6	M6x8			M8x8
X	Ø1,2	Ø1,2	Ø1,2	Ø2,0	Ø2,0
C	Ø0,7	Ø0,7	Ø1,5	Ø1,2	Ø1,5

DPE* restrictors

	M5x6	M6x8	M6x8	M6x8	M6x8
X	Ø0,8	Ø0,7	Ø1	Ø1	Ø1
C	Ø0,6	Ø0,6	Ø0,8	Ø0,8	Ø0,8
Z1	Ø0,6	Ø0,6	Ø0,6	Ø0,6	Ø0,6

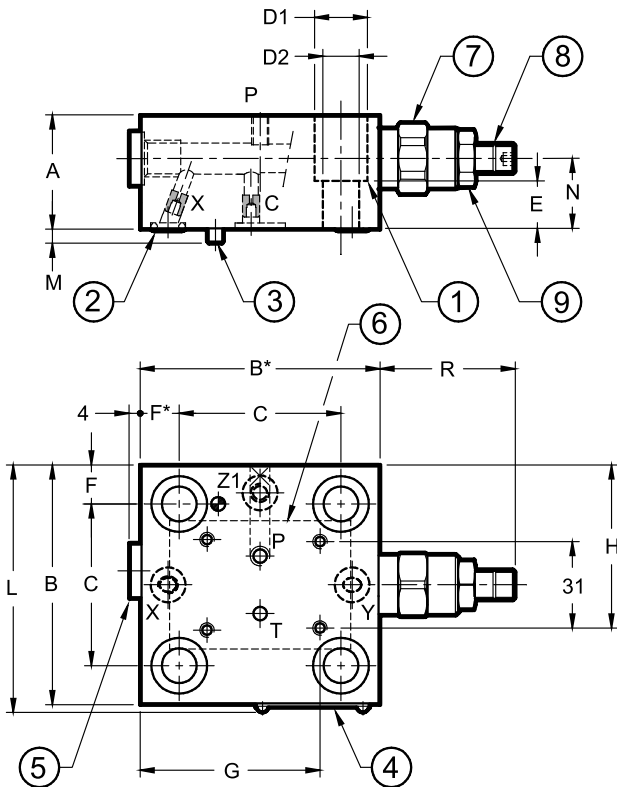

1	N. 4 fastening bolts (NOTE): 16 = M8x30 25 = M12x35 32 = M16x45 40 = M20x50 40 = M20x60 63 = M30x80
2	n° 3 90 Shore sealing rings : 16 = OR type 2025 (6.07x1.78) 25 = OR type 2037 (9.25x1.78) 32 = OR type 2043 (10.82x1.78) 40 and 50 = n° 3 OR type 2050 (12.42x1.78) 63 = OR type 3062 (15.54x2.62)
3	Locating pin: 16 = Ø3x10 25, 32 and 40 = Ø5x14 50 and 63 = Ø6x14

4	Identification label
5	Plug X: 1/4" BSP
6	Mounting surface ISO 4401-03
7	Pressure control valve
8	Countersunk hex adjustment screw: Allen key 6 Clockwise rotation to increase pressure
9	Locking nut: spanner 19

NOTE: Fastening bolts class 10.9 ISO 4762 are recommended for the installation of the cover (to be ordered separately). Tightening torques at par. 9

11 - MONITORED LOGIC ELEMENTS

Monitored logic elements are made of a cartridge valve with directional function and of a cover with built-in inductive proximity sensor. The PNP type sensor with closed contact states the condition of A↔B intercepted flow.



WARNING! These valves must be installed and commissioned by qualified personnel only. Before starting any installation, commissioning or maintenance, it is mandatory to read the *Manual of Use and Maintenance*, delivered together with the valve.

11.1 - TÜV Certification

The LCM*-QD4 monitored logic elements were tested on a voluntary basis by TÜV and found to comply with the applicable requirements of the following standard:

- EN ISO 4413:2012 Hydraulic fluid power – General rules and safety requirements for systems and their components

The components can be considered well tried if they comply the basic safety principles and the well tried safety principles specified in tables C.1 and C.2 of the EN ISO 13849-2:2013 standard depending on the specific application.

The LCM*-QD4 family can be used in safety related parts of control system in category 1 (or higher) as indicated in the standard EN ISO 13849-1:2015. Possible applications are:

- EN 20430:2020 standards - Machines for plastics and rubber - Injection presses - Safety requirements
- EN 16092-3:2018 - Machine tool safety - Presses - Part 3: Safety requirements for hydraulic presses
- EN 12622:2014 - Machine tool safety - Hydraulic press brakes
- EN 422:2009 - Machines for rubber and plastic - Safety requirements.

The state of well-tried component is mainly application specific.

Certificate: **TÜV IT 14 MAC 0042**



11.2 - Identification code of monitored logic elements

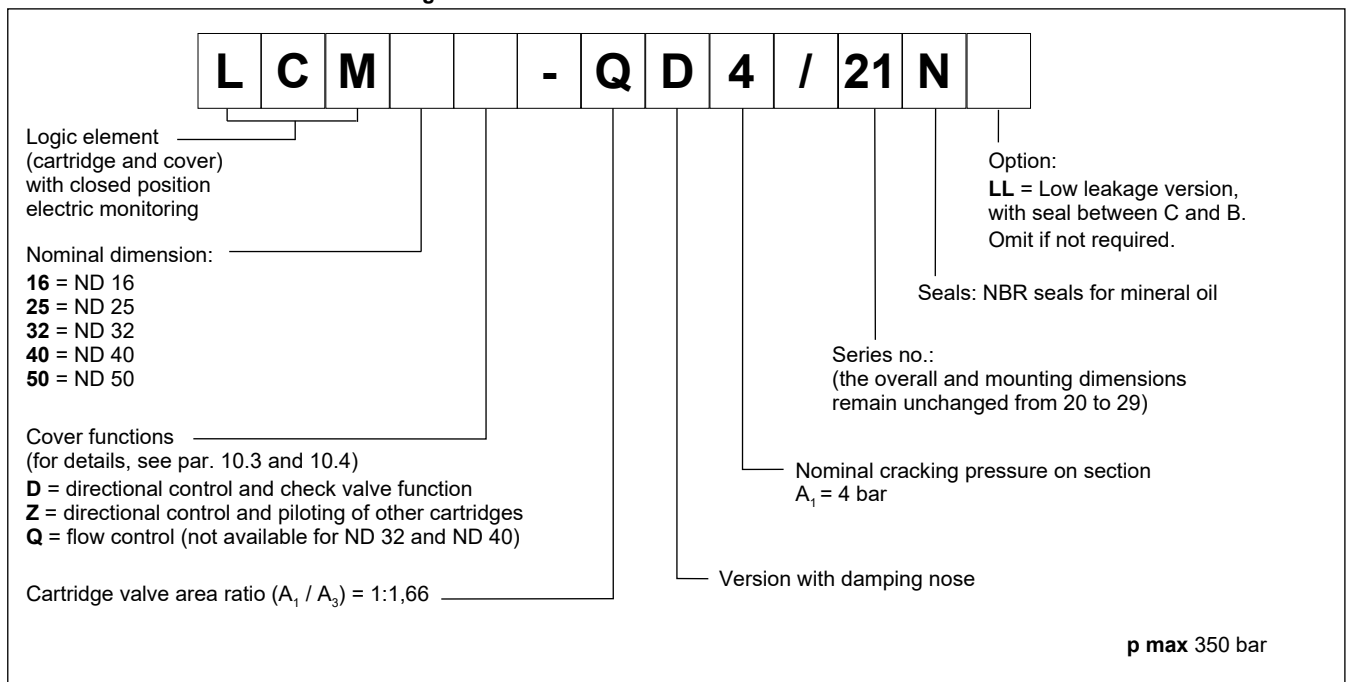

11.3 - Characteristic curves

(values obtained with viscosity 36 cSt at 50°C)

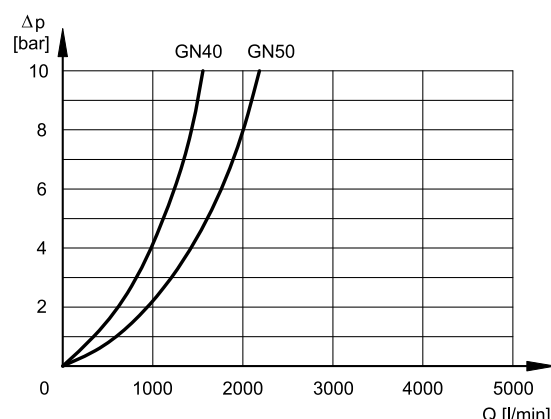
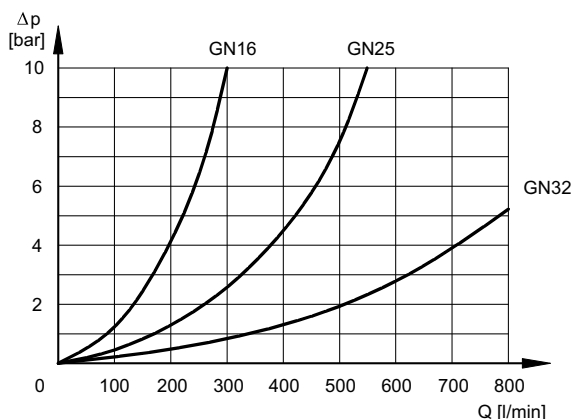

11.4 - Functional diagram of logic element type D, for directional control and check valve function.

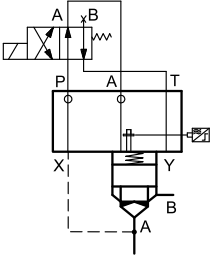
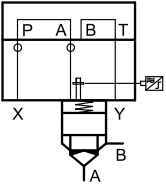
Functional diagram	Description
	<p>Piloting of cartridge valve by means of a solenoid valve type DS3-TA (to be ordered separately - see catalogue 41 150)</p> <ul style="list-style-type: none"> - solenoid valve OFF = A → B intercepted flow - solenoid valve ON = A ↔ B free flow
	<p>Piloting of cartridge valve by means of connection plate code 1950751 to be ordered separately.</p>

11.5 - Functional diagrams of logic element type Z, for directional control and piloting of other cartridges

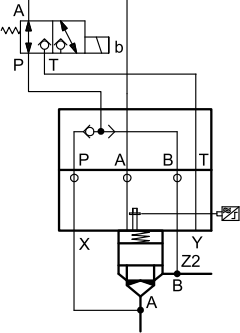
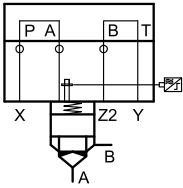
Functional diagram	Description
	<p>Piloting of cartridge valve by means of a solenoid poppet valve type DT03-3A (to be ordered separately - see catalogue 42 200).</p> <p>ISO 4401-03 manifold type DN6 (cod.0294329 - to be ordered separately) that allows to intercept the flow from two lines, obtaining a tight or the free flow.</p> <ul style="list-style-type: none"> - solenoid valve OFF = sealing tight - A ↔ B locked flow - solenoid valve ON = flow A ↔ B free flow
	<p>Piloting of cartridge valve by means of connection plate code 1950751, to be ordered separately.</p>

11.6 - Functional diagrams of logic element type Q, for flow control function

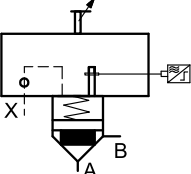
Functional diagram	Description
	<p>Flow control function by means of cover with stroke limiter.</p> <p>This cover is coupled with a cartridge QD4 type, in order to obtain a better flow control and to avoid the wear of the seat.</p>

11.7 - Overall and mounting dimensions of monitored logic elements types D and Z

dimensions in mm

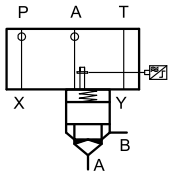

LCM16D-QD4
LCM25D-QD4
LCM32D-QD4
LCM40D-QD4
LCM50D-QD4

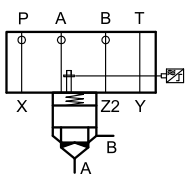
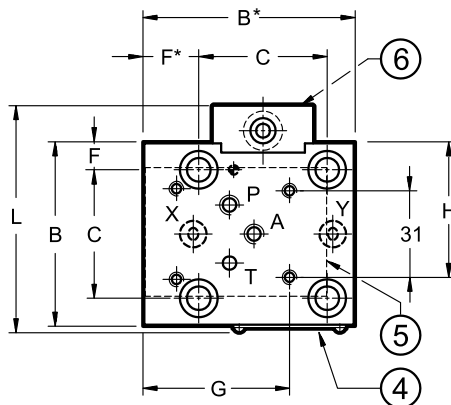
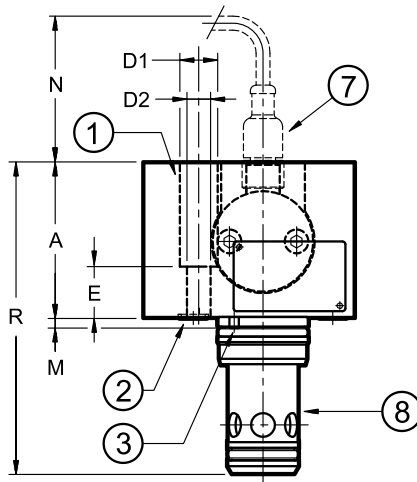

LCM16Z-QD4
LCM25Z-QD4
LCM32Z-QD4
LCM40Z-QD4
LCM50Z-QD4

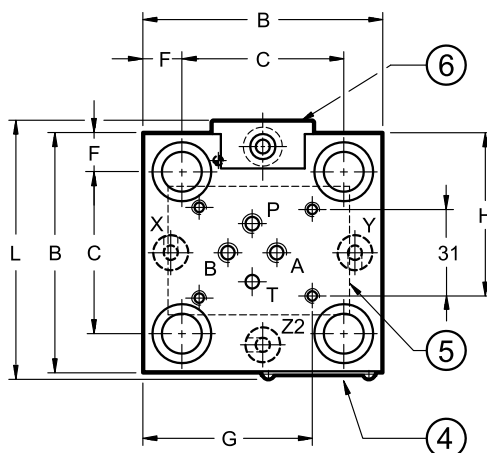

	NOMINAL SIZE				
	16	25	32	40	50
A (NOTE 1)	55	60	70	75	90
B	65	85	102	125	140
B*	75	-	-	-	-
C	46	58	70	85	100
D1	13,5	19	25	31	31
D2	8,5	12,5	17	21	21
E	18	17	22	30	30
F*	19,5	-	-	-	-
F	9,5	13,5	16	20	20
G	52	60,2	68,7	80,2	87,7
H	48	58	66,5	105	85,5
L	81	92	104,5	127,5	142,5
M	4	5	5	5	5
N	70	70	65	60	55
R (NOTE 1)	111	132	155	180	212

ports ready for restrictors M6x8.5	P, A B (on cover Z only)				
Mass [kg]	2,1	3,3	5,3	9,5	14,5

1	N. 4 fastening bolts (NOTE): 16 = M8x30 40 = M20x60 25 = M12x35 50 = M20x60 32 = M16x45
2	n° 3 sealing rings 90 Shore : 16 = OR type 2025 (6.07x1.78) (for ND 16 there are only 2 OR) 25 = OR type 2037 (9.25x1.78) 32 = OR type 2043 (10.82x1.78) 40 and 50 = OR type 2050 (12.42x1.78)
3	Locating pin: 16 = Ø3x10 40 = Ø5x14 25 = Ø5x14 50 = Ø6x14 32 = Ø5x14
4	Identification label
5	Mounting surface ISO 4401-03 (CETOP 4.2-4-03-350)
6	Proximity sensor
7	Connector for proximity sensor (to be ordered separately see par. 11.9)
8	Slip-in cartridge valve always supplied with the cover

NOTE 1: For LCM16Z-QD4 only: add 10 mm to the indicated value.

NOTE 2: Fastening bolts class 10.9 ISO 4762 are recommended for cover installation (to be ordered separately). Tightening torques at par. 9. standardized dimensions at par. 6. Dimensions of the cartridge valve seat at par. 5.

11.8 - Overall and mounting dimensions of monitored logic elements type Q

dimensions in mm

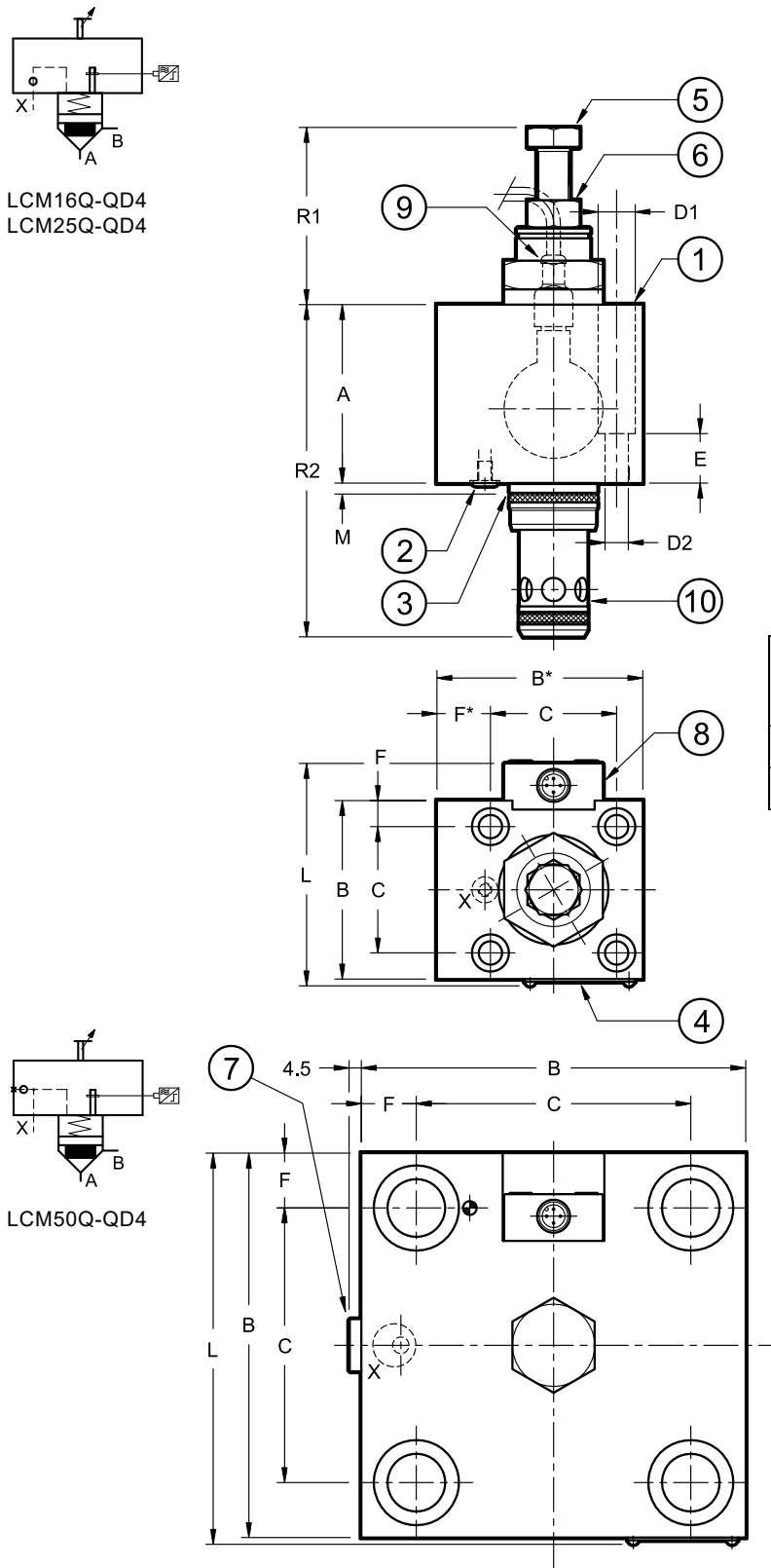

	NOMINAL SIZE		
	16	25	50
A	65	70	130
B	65	85	140
B*	75	-	-
C	46	58	100
D1	13,5	19	31
D2	8,5	12,5	21
E	18	17	30
F*	19,5	-	-
F	9,5	13,5	20
L	81	92	142,5
M	4	5	5
R1	52 ÷ 64,5	48,3 ÷ 64,5	38,7 ÷ 62,5
R2	121	142	152

ports ready for restrictors	port X		
	M5x8	M6x8	
Mass [kg]	2,1	4,0	19,3

1	N. 4 fastening bolts (NOTE): 16 = M8x30 25 = M12x35 50 = M20x60
2	Sealing rings 90 Shore: 16 = n° 1 OR type 2025 (6.07x1.78) 25 = n° 1 OR type 2037 (9.25x1.78) 40 = n° 1 OR type 2050 (12.42x1.78)
3	Locating pin: 16 = Ø3x10 25 = Ø5x14 50 = Ø6x14
4	Identification label
5	Stroke limiter clockwise rotation to reduce stroke 16 = 1 turn: 1,25 mm - spanner 18 25 = 1 turn: 1,25 mm - spanner 18 50 = 1 turn: 2,50 mm - spanner 30
6	Locking nut: 16 = spanner 19 25 = spanner 19 50 = spanner 30
7	Plug X: 50 = 1/4" BSP
8	Proximity sensor
9	Connector for proximity sensor (to be ordered separately see par. 11.9)
10	Slip-in cartridge valve always supplied with the cover

NOTES: Fastening bolts class 10.9 ISO 4762 are recommended for cover installation (to be ordered separately). Tightening torques at par. 9. standardized dimensions at par. 6. Dimensions of the cartridge valve seat at par. 5

11.9 - Technical characteristics of proximity sensor and connector

**PROXIMITY SENSOR
PNP TYPE**

Rated voltage	V DC	24
Power supply voltage range	V DC	10 ÷ 30
Absorbed current	mA	200
Output	normally open contact	
Electric protection	polarity inversion short circuit overvoltage	
Electric connection	with connector	
Max operating pressure	bar	350
Operating temperature range	°C	-25 / +80
Class of protection according to IEC EN 60529 standards (atmospheric agents)		IP68
Spool position LED		NO

CONNECTION SCHEME

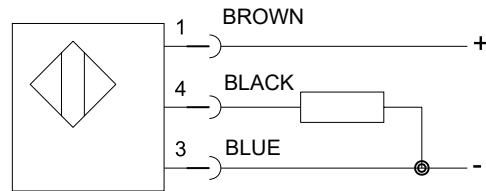

valve closed = closed contact (A↔B intercepted flow)
valve open = open contact (A↔B free flow)

SIGNAL STATUS

According to the safety standards rules, the position signal must change its status before the effective valve opening.

ELECTRIC CONNECTOR (to be ordered separately)

code: ECM3S/M12L/10/L5

Connector: pre-wired connector M12 - IP68

cable: with 3 conductors 0.34 mm² - length 5 mt

cable material: polyurethane resin (oil resistant)

GREEN LED: indicates power supply voltage to the connector.

If the LED is off, the connector is not powered.

YELLOW LED: show the valve status.

- valve at initial position yellow led ON - green led ON
- switched valve yellow led OFF - green led ON



LCM*
SERIES 21

DUPLOMATIC
MOTION SOLUTIONS
*a member of **DAIKIN** group*

DUPLOMATIC MS Spa

via Mario Re Depaolini, 24 | 20015 Parabiago (MI) | Italy

T +39 0331 895111 | E vendite.ita@duplomatic.com | sales.exp@duplomatic.com

duplomaticmotionsolutions.com