

HC2
HYDRAULIC CYLINDERS
HCK2
HYDRAULIC CYLINDERS
ATEX 2014/34/EU
SERIES 20

ISO 6020-2
DIN 24554

DESCRIPTION

- Double acting cylinders constructed in compliance with ISO 6020-2 and DIN 24554.
- The compact design of the square ends with tie rods plus the high quality material and seals render these cylinders highly reliable and therefore strongly recommended for all types of industrial applications.
- The cylinder is available with 14 different mounting styles as well as a vast range of accessories to meet all application requirements.

A - scraper ring
 B - Piston rod seal
 C - Piston seal
 D - Guide rings
 E₁ - Front cushioning adjustment screw
 E₂ - Rear cushioning adjustment screw
 F₁ - Front cushion
 F₂ - Rear cushion
 G - Bushing

ATEX 2014/34/EU rated version for installation in potentially explosive atmospheres is now available. The standard version of cylinders is ATEX II 2GD classified, whereas cylinders with proximity sensors are ATEX II 3GD classified. The declaration of conformity to the up mentioned standards is always supplied with the cylinder. See point 3 for details.

PERFORMANCES

Nominal operating pressure (continuous service)	bar	160
Maximum operating pressure	bar	210
Peak pressure	bar	250
Maximum speed (standard)	m/s	0.5
Maximum stroke (standard)	mm	5000
Fluid temperature range (standard)	°C	-20 / +80
Fluid viscosity range	cSt	10 ÷ 400
Fluid contamination degree		According to ISO 4406:1999 class 20/18/15
Recommended viscosity	cSt	25
Security factor in relation with nominal pressure		≥ 4

1 - CHARACTERISTICS

1.1 Bores and piston rods

Ø 25 to Ø 200 mm bores are available to enable a vast choice according to required force.

Three piston rod diameters are available for each bore (with the exception of the Ø 25 mm bore, for which the intermediate piston rod is not available):

- standard piston rod with 1:1.25 area ratio
- intermediate piston rod with 1:1.45 area ratio
- oversized piston rod with 1:2 area ratio

1.2 - Cushioning

On request, gradual and adjustable cushioning devices can be fitted in the front and/or rear ends of the cylinder without affecting overall dimensions.

The special design of the cushions ensures optimal repeatability also in the event of variations in fluid viscosity.

Cushioning devices are always recommended as they ensure impact-free stopping even at high speed thus reducing pressure surges and impact transferred to the mounting supports.

For all the available bores, cushioning is adjustable by means of a needle.

Rapid piston start-up is guaranteed by the bypass system located inside the front cushioning cone and rear cushioning ring.

The table below shows cushioning cone lengths:

Bore (mm)	25	32	40	50	63	80	100	125	160	200
Front cone length (mm)	17	17	28	28	28	28	30	30	38	45
Rear cone length (mm)	17	17	26	26	26	28	31	30	38	55

1.3 - Connections

The cylinders are supplied as standard with cylindrical BSP threads and spot facing for seal rings in compliance with ISO 1179. Connections which are oversized compared to those shown in the dimensional tables are available upon request. For further information and for the order identification code, please consult our technical office.

For correct cylinder operation, fluid velocity must not exceed 5 m/s.

1.4 - Connection position

Standard positions of the oil ports, cushioning adjustment screws, breathers and end-stroke proximity sensors are shown in the relevant diagram according to the mounting style.

Connection positions different from the standard can be provided upon request.

Other options positions will be rotated accordingly.

For special requests please consult our technical office.

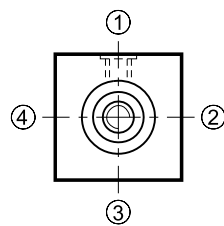

Front view - piston rod side

1.5 - Seals

The table below illustrates seal characteristics in relation to hydraulic fluid and operating temperatures.

Type	Seal type	Seal material	Hydraulic fluid	Minimum pressure [bar]	Operating pressure [°C]	Max speed [m/s]
K	standard	nitrile polyurethane	mineral oil	10	-20 / +80	0,5
M	low friction	nitrile PTFE	mineral oil water glycol	20 (note)	-20 / +80	15
V	high temperature and/or aggressive fluid	Viton PTFE	special fluids	10	-20 / +150	1

NOTE: for lower pressure use consult our technical office

1.6 - Strokes

Standard cylinders are available with strokes up to 6000 mm. Longer cylinder strokes can be supplied on request.

Stroke tolerances are: 0 + 1 mm for strokes up to 1000 mm
0 + 4 mm for strokes up to 6000 mm

1.7 - Spacers

If the cylinder stroke exceeds 1000 mm we recommend the use of spacers which can be inserted to reduce loads on the piston rod bushing and prevent the piston from sticking.

Spacers are constructed in hardened and tempered steel with PTFE facing. Every spacer is 50 mm long.

We recommend to insert n° 1 spacer for strokes from 1001 to 1500 mm, with an increment of n° 1 spacer for every 500 mm stroke. Remember that the overall length of the cylinder increases according to the number of inserted spacers (50 mm for each spacer).

1.8 - Tie rod tightening torque

If cylinder has been disassembled, re-assemble it and tighten the tie rod lock nuts cross-wise applying a gradual torque up to the value indicated in the table below. The values below refer to dry threads.

Bore [mm]	25	32	40	50	63	80	100	125	160	200
Tie rod	M5 x0.8	M6 x1	M8 x1	M12 x12.5	M12 x12.5	M16 x1.5	M16 x1.5	M22 x1.5	M27 x2	M30 x2
Torque [Nm]	5	9	20	70	70	160	160	450	820	1150

1.9 - Breathers

On request cylinder ends can be supplied with breathers for the elimination of air. This is necessary when the entire stroke is not used or when connections are not facing upwards.

1.10 - Surface finish

Standard cylinders are supplied painted with Duplomatic black opaque colour with a paint thickness of 40µm. The rod is chromed.

MOUNTING STYLES

F = front-end T = rear end	A		B		C		D		F		G		H		L		N		P		Q		R		T		U		
	T	F	T	F	T	F	T	F	T	F	T	F	T	F	T	F	T	F	T	F	T	F	T	F	T	F	T	F	
Connections	1	1	1	1	1	1	1	1	1	1	1	1	1	1	1	1	1	1	1	1	1	1	1	1	1	1	1	1	1
	2	2	2	2	2	2	2	2	2	2	2	2	2	2	2	2	2	2	2	2	2	2	2	2	2	2	2	2	2
	3	3	3	3	3	3	3	3	3	3	3	3	3	3	3	3	3	3	3	3	3	3	3	3	3	3	3	3	3
	4	4	4	4	4	4	4	4	4	4	4	4	4	4	4	4	4	4	4	4	4	4	4	4	4	4	4	4	4
Cushioning	1	1	1	1	1	1	1	1	1	1	1	1	1	1	1	1	1	1	1	1	1	1	1	1	1	1	1	1	
	2	2	2	2	2	2	2	2	2	2	2	2	2	2	2	2	2	2	2	2	2	2	2	2	2	2	2	2	2
	3	3	3	3	3	3	3	3	3	3	3	3	3	3	3	3	3	3	3	3	3	3	3	3	3	3	3	3	3
	4	4	4	4	4	4	4	4	4	4	4	4	4	4	4	4	4	4	4	4	4	4	4	4	4	4	4	4	4
Breathers	1	1	1	1	1	1	1	1	1	1	1	1	1	1	1	1	1	1	1	1	1	1	1	1	1	1	1	1	
	2	2	2	2	2	2	2	2	2	2	2	2	2	2	2	2	2	2	2	2	2	2	2	2	2	2	2	2	2
	3	3	3	3	3	3	3	3	3	3	3	3	3	3	3	3	3	3	3	3	3	3	3	3	3	3	3	3	3
	4	4	4	4	4	4	4	4	4	4	4	4	4	4	4	4	4	4	4	4	4	4	4	4	4	4	4	4	4
End-stroke proximity sensors	1	1	1	1	1	1	1	1	1	1	1	1	1	1	1	1	1	1	1	1	1	1	1	1	1	1	1	1	
	2	2	2	2	2	2	2	2	2	2	2	2	2	2	2	2	2	2	2	2	2	2	2	2	2	2	2	2	2
	3	3	3	3	3	3	3	3	3	3	3	3	3	3	3	3	3	3	3	3	3	3	3	3	3	3	3	3	3
	4	4	4	4	4	4	4	4	4	4	4	4	4	4	4	4	4	4	4	4	4	4	4	4	4	4	4	4	4

NOTES: Positions highlighted with a grey background are relevant to the standard, the others refer to the available options. For Ø25, Ø32, and Ø40 bores with Ø18 and Ø22 rods, in the positions marked with an asterisk, it is necessary to choose between cushioning and breathers. For end-stroke proximity sensors, refer to the limitations indicated in point 22.

2 - IDENTIFICATION CODE

K = Explosion-proof version according to ATEX 2014/34/EU (point 3). Omit if not required.

HC	2	-	/	/	-	-	-	-	/	/	20
----	---	---	---	---	---	---	---	---	---	---	----

MOUNTING STYLE	
	A = Front flange (ME5)
	B = Rear flange (ME6)
	C = Female clevis (MP1)
	D = Male clevis (MP3)
	F = Spheric swivel (MP5)
	G = Feet (MS2)
	H = Front swinging (MT1)
	L = Mid swinging (MT4)
	N = Rear swinging (MT2)
	P = Front tie rods (MX3)
	Q = Back tie rods (MX2)
	R = Front and back tie rods (MX1)
	T = Front threaded holes (MX5)
	U = Back threaded holes (MX6)

Series (put for spare parts requests)

Dimension XV for "L" mounting (omit for other mounting styles)

N° of spacers multiple of 50 mm (omit if not required) see p. 1.7

Rear end connection position (1-4) (see point 1.4)

Front end connection position (1-4) (see point 1.4)

Breathers (see point 1.9)

0 = without breathers

S = front and back breathers

Cushioning (see point 1.2):

0 = without cushioning

1 = front

2 = back

3 = front and back

Seals (see p. 1.5):

K = standard (nitrile + polyurethane)

M = low friction (nitrile + PTFE)

V = high temperature (viton + PTFE)

Stroke (mm) - (For cylinders with spacers indicate the working stroke)

Double rod threading (omit if not required)

See single rod for type and dimensions

Double rod (omit if not required)

See single rod for dimensions.

Not available with mounting style B - C - D - F - N - Q - U

Rod threading: Male thread (standard)

W = Female thread

X = Light male thread

Y = Light female thread (see point 4)

Ø Rod (mm)	Rods available for each bore									
12	•									
14		•								
18	•	•	•							
22		•	•	•						
28			•	•	•					
36				•	•	•				
45					•	•	•			
56						•	•	•		
70							•	•	•	
90								•	•	•
110									•	•
140										•
Bore (mm)	25	32	40	50	63	80	100	125	160	200

3 - ATEX 2014/34/EU RATED VERSION

ATEX 2014/34/EU rated version cylinders for installation in potentially explosive atmospheres are now available. The standard version of cylinders is ATEX II 2GD classified, whereas cylinders with proximity sensors are ATEX II 3GD classified.

The supply is always delivered accompanied by:

- the ATEX declaration of conformity
- the operating and maintenance user manual, where are described all the information for the proper use of cylinders in potentially explosive environments.

TYPE EXAMINATION CERTIFICATE N°: **CEC 10 ATEX 138**

3.1 - Identification code

To order the ATEX-rated version, simply insert the letter K in the initial part of the identification code. The description becomes HCK2-*

For cylinders without end-stroke proximity sensors please order with the identification code shown at point 2.1.

Example: HCK2C-200/90-500-K3-S-11/20

For cylinders equipped with end-stroke proximity sensors please refer to the identification code shown at point 22.1.

Example: HCK2F-FP22-80/56-200-K3-S-11/20

The ATEX-rated cylinders equipped with end-stroke proximity sensors are compliant with the specifications listed point 22; Also the same limitations described in that point are effective. (NB: for bores Ø160 and Ø200 contact our technical department).

The proximity sensors are compliant with the description and the wiring diagram shown at the point 22.2.

3.2 - Classification

Cylinders without end-stroke proximity sensors have this ATEX mark:

Ex II 2GD ck IIC T4 (-20°C Ta +80°C)

EX: Specific marking of explosion protection as ATEX 2014/34/EU directive and related technical specification requests.

II: Group II for surface plants

2: Category 2 high protection, eligible for zone 1 for gases and zone 21 for dust (automatically be eligible for zone 2 category 3 for gases and zone 22 for dust)

GD: for use in areas in which explosive atmospheres caused by gases, vapours, mists or air/dust mixtures.

ck: protection by constructional safety and by liquid immersion

IIC: Gas group

(automatically eligible for group IIA and IIB)

T4: Temperature class for gas (max surface temperature)

-20°C Ta +80°C: Ambient temperature range

Cylinders with end-stroke proximity sensors have this ATEX mark:

Ex II 3GD ck IIC T4 (-20°C Ta +80°C)

EX: Specific marking of explosion protection as ATEX 2014/34/EU directive and related technical specification requests

II: Group II for surface plants

3: Category 3 standard protection, eligible for zone 2 for gases (zone 22 for dust)

GD: for use in areas in which explosive atmospheres caused by gases, vapours, mists or air/dust mixtures.

ck: protection by constructional safety and by liquid immersion

IIC: Gas group

(automatically eligible for group IIA and IIB)

T4: Temperature class for gas (max surface temperature)

-20°C Ta +80°C: Ambient temperature range

3.3 - Operating temperatures

The operating ambient temperature must be between -20°C and +80 °C.

The fluid temperature for the standard version seals (K) and for low friction seals (M) must be between -20°C and +80°C, as for viton (V) seals must be between -20°C and +120 °C.

The actuators are T4 (T135° C) class temperature classified, so they are eligible for operation also at higher class temperature (T3, T2, T1 (T200° C).

3.4 - Admitted velocities

The maximum permissible speed is 0.5 m/s for standard cylinder seals (K) and 1 m/s for actuators with low friction seals (M) or Viton (V).

3.5 - Connectors

The connectors for the end-stroke proximity are available upon request. They are metal, to be wired. The ordering code is **0680961**. One connector per sensor is needed.

3.6 - Grounding points

The ATEX certified actuators are supplied with two grounding points, one on the rear head and one on the rod, for the wire of the cylinder with the ground (M4 screws).

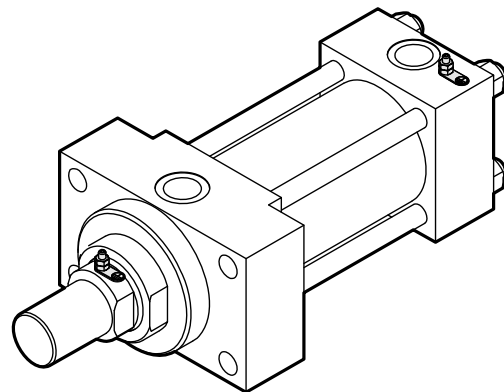

The bottom grounding point must always be connected whereas the connection of the rod grounding point can be avoided in case the whole mechanical stroke is covered during the cylinder operating phase (from the mechanical stop on the cylinder head to the mechanical stop on the bottom), or in case the rod has already been grounded through the mechanical connection between the rod itself and the machine/plan it is installed on.

In order to verify such a condition it is necessary to test the equipotentiality of the parts and a maximum resistance equal to 100Ω as per the EN13463-1 norm.

4 - OVERALL AND MOUNTING DIMENSIONS

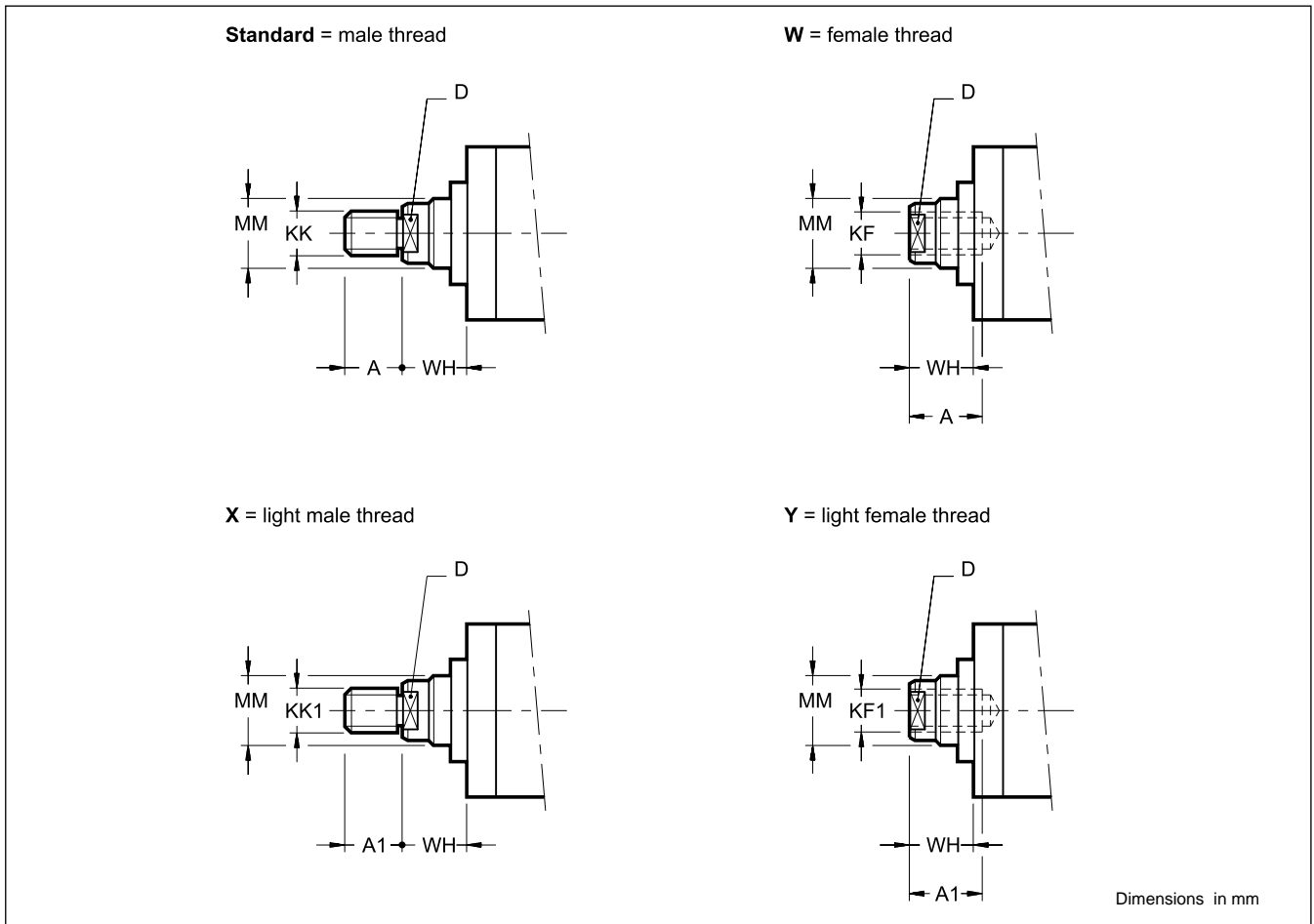

Dimensions in mm

Bore	MM Ø rod	KK	KK1	KF	KF1	A	A1	D	WH
25	12	M10x1.25	-	M8x1	-	14	-	9	15
	18	M14x1.5	M10x1.25	M12x1.25	M8x1	18	14	14	
32	14	M12x1.25	-	M10x1.25	-	16	-	11	
	18	M14x1.5	M10x1.25	M12x1.25	M8x1	18	14	14	25
	22	M16x1.5	M12x1.25	M16x1.5	M10x1.25	22	16	17	
40	18	M14x1.5	M10x1.25	M12x1.25	M8x1	18	14	14	
	22	M16x1.5	M12x1.25	M16x1.5	M10x1.25	22	16	17	25
	28	M20x1.5	M14x1.5	M20x1.5	M12x1.25	28	18	22	
50	22	M16x1.5	M12x1.25	M16x1.5	M10x1.25	22	16	17	
	28	M20x1.5	M14x1.25	M20x1.5	M12x1.25	28	18	22	26
	36	M27x2	M16x1.5	M27x2	M16x1.5	36	22	30	
63	28	M20x1.5	M14x1.5	M20x1.5	M12x1.25	28	18	22	
	36	M27x2	M16x1.5	M27x2	M16x1.5	36	22	30	33
	45	M33x2	M20x1.5	M33x2	M20x1.5	45	28	36	
80	36	M27x2	M16x1.5	M27x2	M16x1.5	36	22	30	
	45	M33x2	M20x1.5	M33x2	M20x1.5	45	28	36	31
	56	M42x2	M27x2	M42x2	M27x2	56	36	50	
100	45	M33x2	M20x1.5	M33x2	M20x1.5	45	28	36	
	56	M42x2	M27x2	M42x2	M27x2	56	36	50	35
	70	M48x2	M33x2	M48x2	M33x2	63	45	60	
125	56	M42x2	M27x2	M42x2	M27x2	56	36	50	
	70	M48x2	M33x2	M48x2	M33x2	63	45	60	35
	90	M64x3	M42x2	M64x3	M42x2	85	56	80	
160	70	M48x2	M33x2	M48x2	M33x2	63	45	60	
	90	M64x3	M42x2	M64x3	M42x2	85	56	80	32
	110	M80x3	M48x2	M80x3	M48x2	95	63	100	
200	90	M64x3	M42x2	M64x3	M42x2	85	56	80	
	110	M80x3	M48x2	M80x3	M48x2	95	63	100	32
	140	M100x3	M64x3	M100x3	M64x3	112	85	130	

5 - OVERALL AND MOUNTING DIMENSIONS ISO/DIN ME5

A FRONT FLANGE

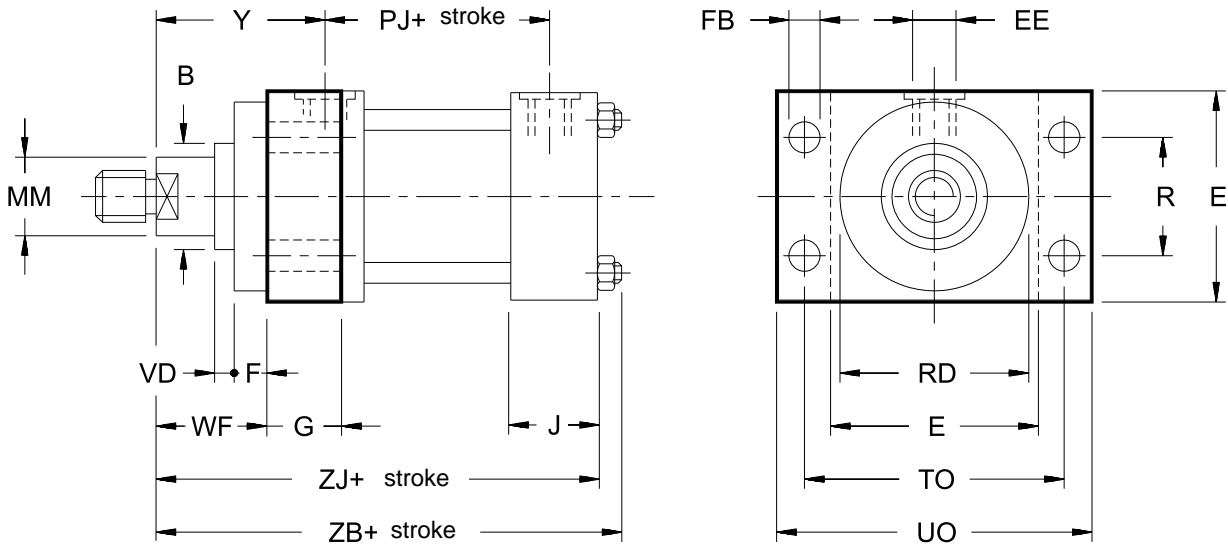

NOTE: The "E" dimension indicated in the table (bores 25 and 32) must be increased of 5 mm, only for the front end, on the oil port side (dimensions not in compliance with ISO standards).

Dimensions in mm

Bore	MM Ø rod	ØB f8	E max	EE BSP	F	ØFB	G	J	PJ	R	ØRD f8	TO	UO max	VD	WF	Y	ZB	ZJ
25	12 18	24 30	40 NOTE	1/4"	10	5.5	35	35	54	27	38	51	65	6	25	50	121	114
32	14 18 22	26 30 34	45 NOTE	1/4"	10	6.6	36	36	57	33	42	58	70	12 6 12	35	60	137	128
40	18 22 28	30 34 42	63	3/8"	10	11	45	45	74	41	62	87	110	6 12 10	35	62	166	153
50	22 28 36	34 42 50	75	1/2"	16	14	45	45	76	52	74	105	130	7 7 10	41	68	176	159
63	28 36 45	42 50 60	90	1/2"	16	14	45	45	80	65	75 88 88	117	145	7 10 14	48	71	185	168
80	36 45 56	50 60 72	115	3/4"	20	18	50	52	93	83	82 105 105	149	180	5 9 9	51	77	212	190
100	45 56 70	60 72 88	130	3/4"	22	18	50	55	101	97	92 125 125	162	200	7 7 10	57	82	225	203
125	56 70 90	72 88 108	165	1"	22	22	55	71	117	126	105 150 150	208	250	7 10 10	57	86	260	232
160	70 90 110	88 108 133	205	1"	25	26	63	63	130	155	125 170 170	253	300	7	57	86	279	245
200	90 110 140	108 133 163	245	1.1/4"	25	33	80	80	165	190	150 210 210	300	360	7	57	98	336	299

6 - OVERALL AND MOUNTING DIMENSIONS ISO/DIN ME6

B REAR FLANGE

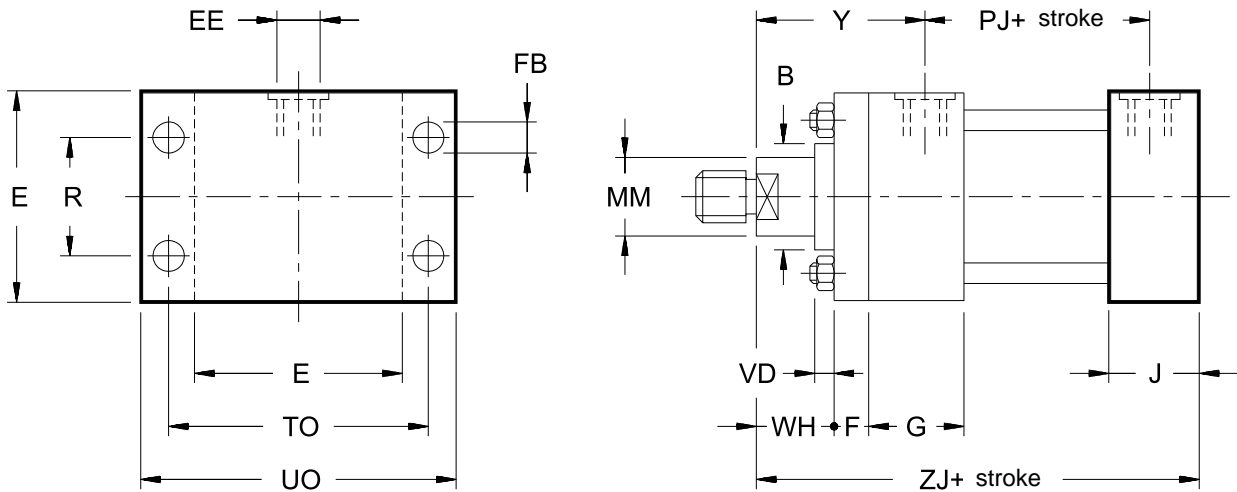

NOTE: The "E" dimension indicated in the table (bores 25 and 32) must be increased of 5 mm, only for the front end, on the oil port side (dimensions not in compliance with ISO standards).

Dimensions in mm

Bore	MM Ø rod	ØB f8	E max	EE BSP	F	ØFB	G	J	PJ	R	TO	UO max	VD	WH	Y	ZJ
25	12	24	40	1/4"	10	5.5	45	35	54	27	51	65	6	15	50	114
	18	30	NOTE													
32	14	26	45	1/4"	10	6.6	45	36	57	33	58	70	12	25	60	128
	18	30	NOTE										6			
	22	34										12				
40	18	30	63	3/8"	10	11	55	45	74	41	87	110	6	25	62	153
	22	34											12			
	28	42											10			
		28	42	75	1/2"	15	14	55	45	76	52	105	130	7	26	68
50	22	34	90	1/2"	15	14	55	45	80	65	117	145	7	33	71	168
	28	42											10			
	36	50											14			
80	36	50	115	3/4"	20	18	65	52	93	83	149	180	5	31	77	190
	45	60											9			
	56	72											9			
100	45	60	130	3/4"	22	18	69	55	101	97	162	200	7	35	82	203
	56	72											7			
	70	88											10			
125	56	72	165	1"	22	22	78	71	117	126	208	250	7	35	86	232
	70	88											10			
	90	108											10			
160	70	88	205	1"	25	26	86	63	130	155	253	300	7	32	86	245
	90	108														
	110	133														
200	90	108	245	1.1/4"	25	33	103	80	165	190	300	360	7	32	98	299
	110	133														
	140	163														

7 - OVERALL AND MOUNTING DIMENSIONS ISO MP1

C FEMALE CLEVIS (with PIN and spring retainers)

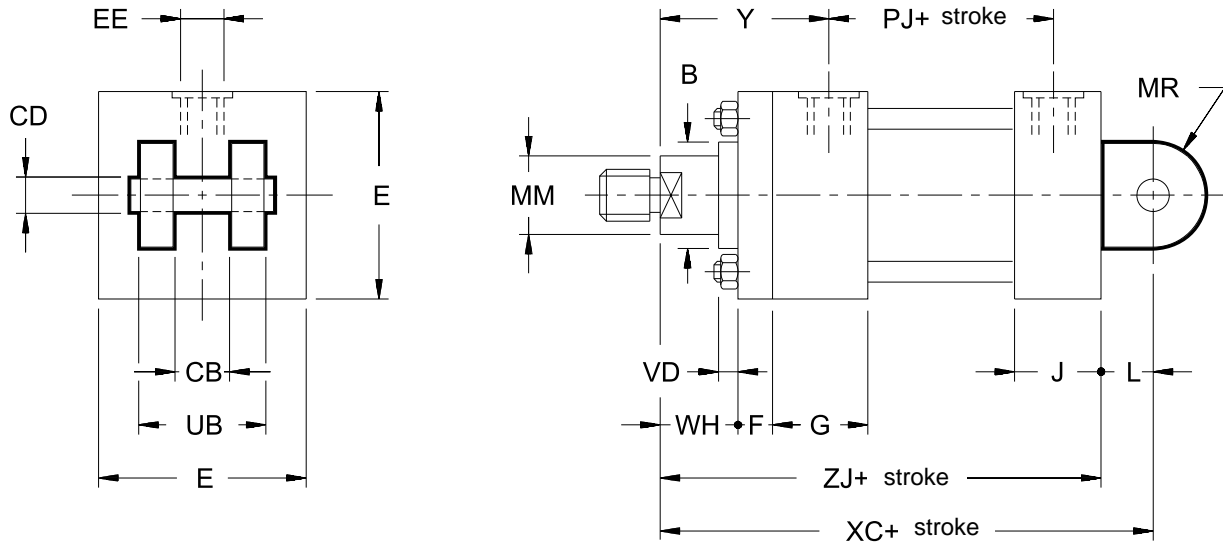

NOTE: The "E" dimension indicated in the table (bores 25 and 32) must be increased of 5 mm, only for the front end, on the oil port side (dimensions not in compliance with ISO standards).

Dimensions in mm

Bore	MM Ø rod	ØB f8	CB A16	ØCD f8	E max	EE BSP	F	G	J	L	MR	PJ	UB	VD	WH	XC	Y	ZJ
25	12 18	24 30	12	10	40 NOTE	1/4"	10	45	35	13	12	54	24	6	15	127	50	114
32	14 18 22	26 30 34	16	12	45 NOTE	1/4"	10	45	36	19	17	57	32	12 6 12	25	147	60	128
40	18 22 28	30 34 42	20	14	63	3/8"	10	55	45	19	17	74	40	6 12 10	25	172	62	153
50	22 28 36	34 42 50	30	20	75	1/2"	15	55	45	32	29	76	60	7 7 10	26	191	68	159
63	28 36 45	42 50 60	30	20	90	1/2"	15	55	45	32	29	80	60	7 10 14	33	200	71	168
80	36 45 56	50 60 72	40	28	115	3/4"	20	65	52	39	34	93	80	5 9 9	31	229	77	190
100	45 56 70	60 72 88	50	36	130	3/4"	22	69	55	54	50	101	100	7 7 10	35	257	82	203
125	56 70 90	72 88 108	60	45	165	1"	22	78	71	57	53	117	120	7 10 10	35	289	86	232
160	70 90 110	88 108 133	70	56	205	1"	25	86	63	63	59	130	140	7	32	308	86	245
200	90 110 140	108 133 163	80	70	245	1.1/4"	25	103	80	82	78	165	160	7	32	381	98	299

8 - OVERALL AND MOUNTING DIMENSIONS ISO MP3

D MALE CLEVIS

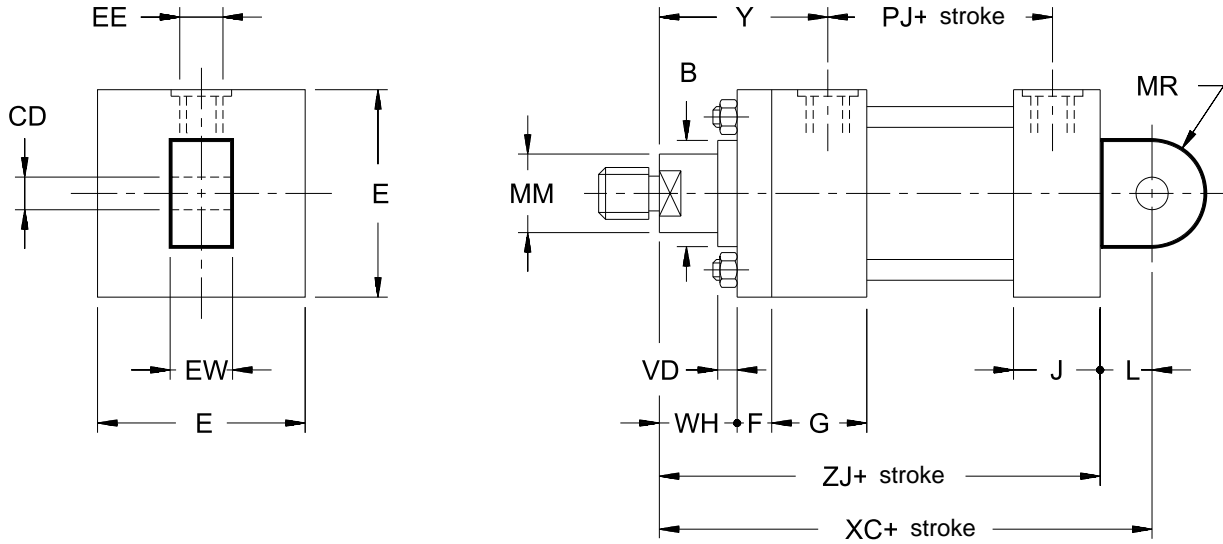

NOTE: The "E" dimension indicated in the table (bores 25 and 32) must be increased of 5 mm, only for the front end, on the oil port side (dimensions not in compliance with ISO standards).

Dimensions in mm

Bore	MM Ø rod	ØB f8	ØCD H9	E max	EE BSP	EW h9	F	G	J	L	MR	PJ	VD	WH	XC	Y	ZJ
25	12 18	24 30	10	40 NOTE	1/4"	12	10	45	35	13	12	54	6	15	127	50	114
32	14 18 22	26 30 34	12	45 NOTE	1/4"	16	10	45	36	19	17	57	12 6 12	25	147	60	128
40	18 22 28	30 34 42	14	63	3/8"	20	10	55	45	19	17	74	6 12 10	25	172	62	153
50	22 28 36	34 42 50	20	75	1/2"	30	15	55	45	32	29	76	7 7 10	26	191	68	159
63	28 36 45	42 50 60	20	90	1/2"	30	15	55	45	32	29	80	7 10 14	33	200	71	168
80	36 45 56	50 60 72	28	115	3/4"	40	20	65	52	39	34	93	5 9 9	31	229	77	190
100	45 56 70	60 72 88	36	130	3/4"	50	22	69	55	54	50	101	7 7 10	35	257	82	203
125	56 70 90	72 88 108	45	165	1"	60	22	78	71	57	53	117	7 10 10	35	289	86	232
160	70 90 110	88 108 133	56	205	1"	70	25	86	63	63	59	130	7	32	308	86	245
200	90 110 140	108 133 163	70	245	1.1/4"	80	25	103	80	82	78	165	7	32	381	98	299

9 - OVERALL AND MOUNTING DIMENSIONS ISO/DIN MP5

F SPHERIC SWIVEL

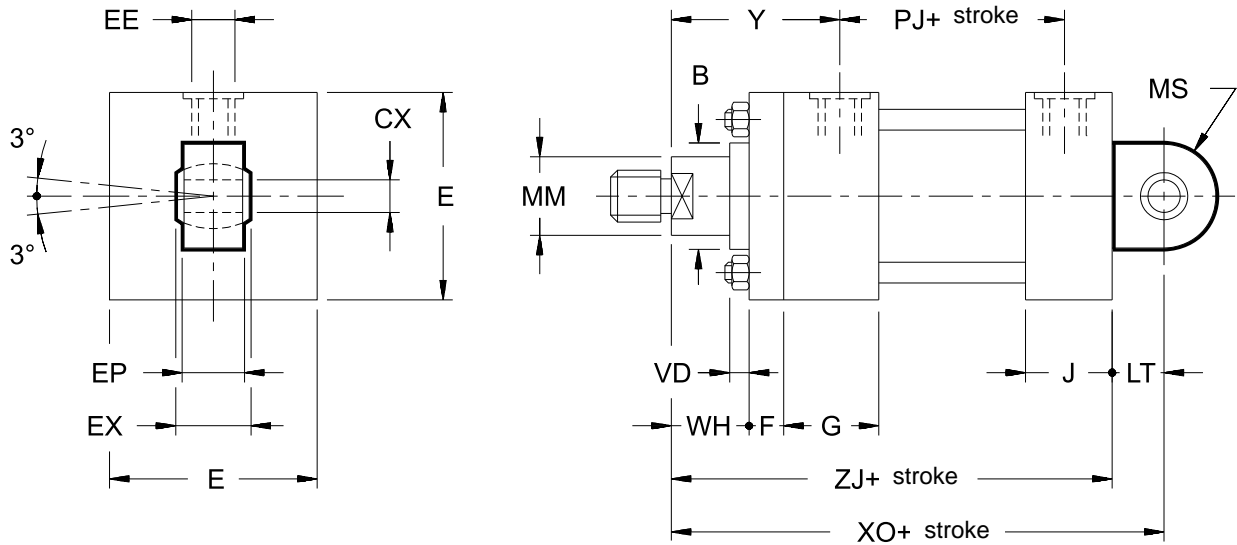

NOTE: The "E" dimension indicated in the table (bores 25 and 32) must be increased of 5 mm, only for the front end, on the oil port side (dimensions not in compliance with ISO standards).

Dimensions in mm

Bore	MM Ø rod	ØB f8	ØCX	E max	EE BSP	EP	EX	F	G	J	LT	MS	PJ	VD	WH	XO	Y	ZJ
25	12 18	24 30	12 ⁰ _{-0.008}	40 NOTE	1/4"	8	10 ⁰ _{-0.12}	10	45	35	16	20	54	6	15	130	50	114
32	14 18 22	26 30 34	16 ⁰ _{-0.008}	45 NOTE	1/4"	11	14 ⁰ _{-0.12}	10	45	36	20	22	57	12 6 12	25	148	60	128
40	18 22 28	30 34 42	20 ⁰ _{-0.012}	63	3/8"	13	16 ⁰ _{-0.12}	10	55	45	25	29	74	6 12 10	25	178	62	153
50	22 28 36	34 42 50	25 ⁰ _{-0.012}	75	1/2"	17	20 ⁰ _{-0.12}	15	55	45	31	33	76	7 7 10	26	190	68	159
63	28 36 45	42 50 60	30 ⁰ _{-0.012}	90	1/2"	19	22 ⁰ _{-0.12}	15	55	45	38	40	80	7 10 14	33	206	71	168
80	36 45 56	50 60 72	40 ⁰ _{-0.012}	115	3/4"	23	28 ⁰ _{-0.12}	20	65	52	48	50	93	5 9 9	31	238	77	190
100	45 56 70	60 72 88	50 ⁰ _{-0.012}	130	3/4"	30	35 ⁰ _{-0.12}	22	69	55	58	62	101	7 7 10	35	261	82	203
125	56 70 90	72 88 108	60 ⁰ _{-0.015}	165	1"	38	44 ⁰ _{-0.15}	22	78	71	72	80	117	7 10 10	35	304	86	232
160	70 90 110	88 108 133	80 ⁰ _{-0.015}	205	1"	47	55 ⁰ _{-0.15}	25	86	63	92	100	130	7	32	337	86	245
200	90 110 140	108 133 163	100 ⁰ _{-0.020}	245	1.1/4"	57	70 ⁰ _{-0.20}	25	103	80	116	120	165	7	32	415	98	299

10 - OVERALL AND MOUNTING DIMENSIONS ISO/DIN MS2

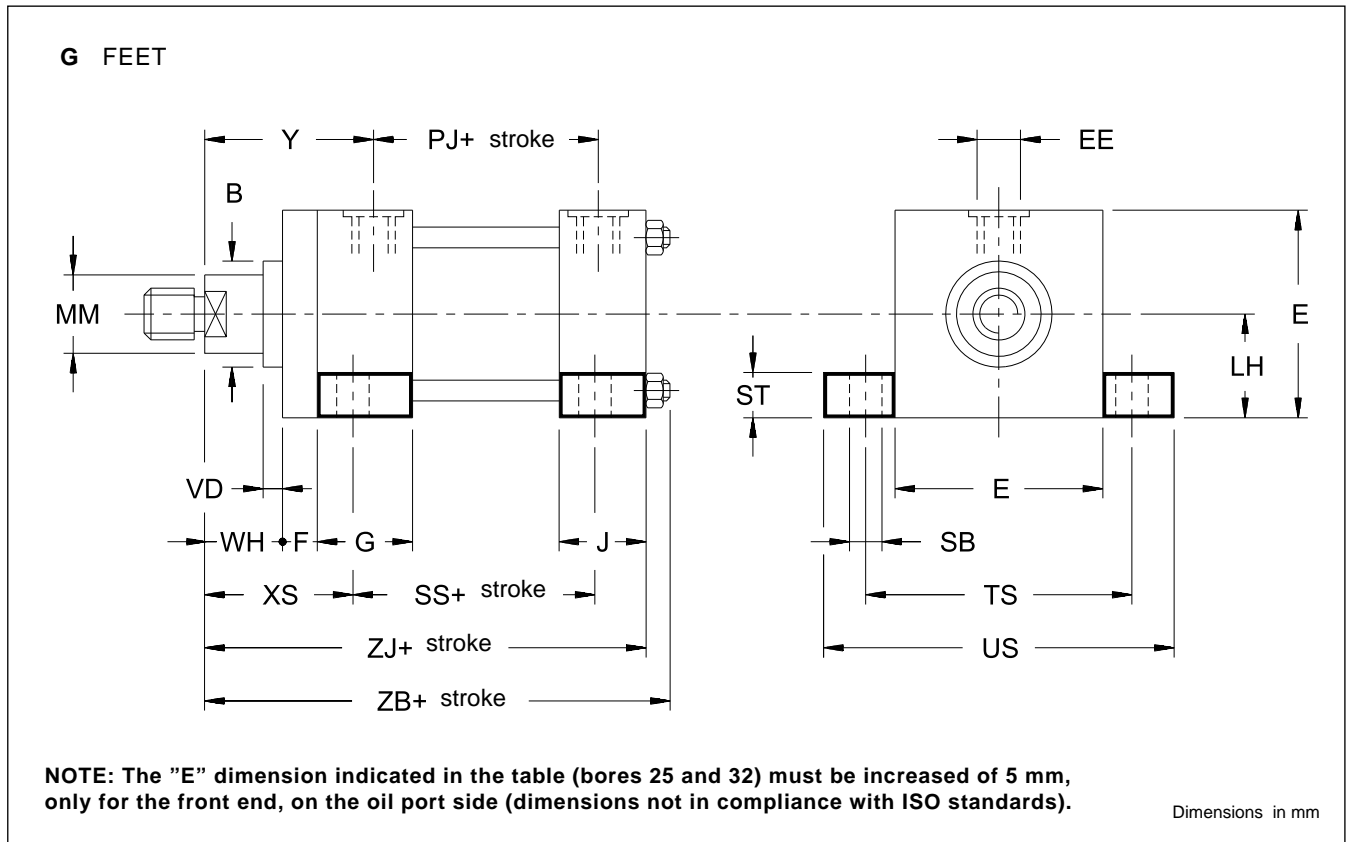

Bore	MM Ø rod	ØB f8	E max	EE BSP	F	G	J	LH h10	PJ	ØSB	SS	ST	TS	US max	VD	WH	XS	Y	ZB	ZJ
25	12	24	40	1/4"	10	45	35	19	54	6.6	73	8.5	54	72	6	15	33	50	121	114
	18	30	NOTE																	
32	14	26	45	1/4"	10	45	36	22	57	9	73	12.5	63	84	12	25	45	60	137	128
	18	30	NOTE	6																
	22	34		12																
40	18	30	63	3/8"	10	55	45	31	74	11	98	12.5	83	103	6	25	45	62	166	153
	22	34		12																
	28	42		10																
50	22	34	75	1/2"	15	55	45	37	76	14	92	19	102	127	7	26	54	68	176	159
	28	42		7																
	36	50		10																
63	28	42	90	1/2"	15	55	45	44	80	18	86	26	124	161	7	33	65	71	185	168
	36	50		10																
	45	60		14																
80	36	50	115	3/4"	20	65	52	57	93	18	105	26	149	186	5	31	68	77	212	190
	45	60		9																
	56	72		9																
100	45	60	130	3/4"	22	69	55	63	101	26	102	32	172	216	7	35	79	82	225	203
	56	72		7																
	70	88		10																
125	56	72	165	1"	22	78	71	82	117	26	131	32	210	254	7	35	79	86	260	232
	70	88		10																
	90	108		10																
160	70	88	205	1"	25	86	63	101	130	33	130	38	260	318	7	32	86	86	279	245
	90	108																		
	110	133																		
200	90	108	245	1.1/4"	25	103	80	122	165	39	172	44	311	381	7	32	92	98	336	299
	110	133																		
	140	163																		

11 - OVERALL AND MOUNTING DIMENSIONS ISO MT1

H FRONT SWINGING

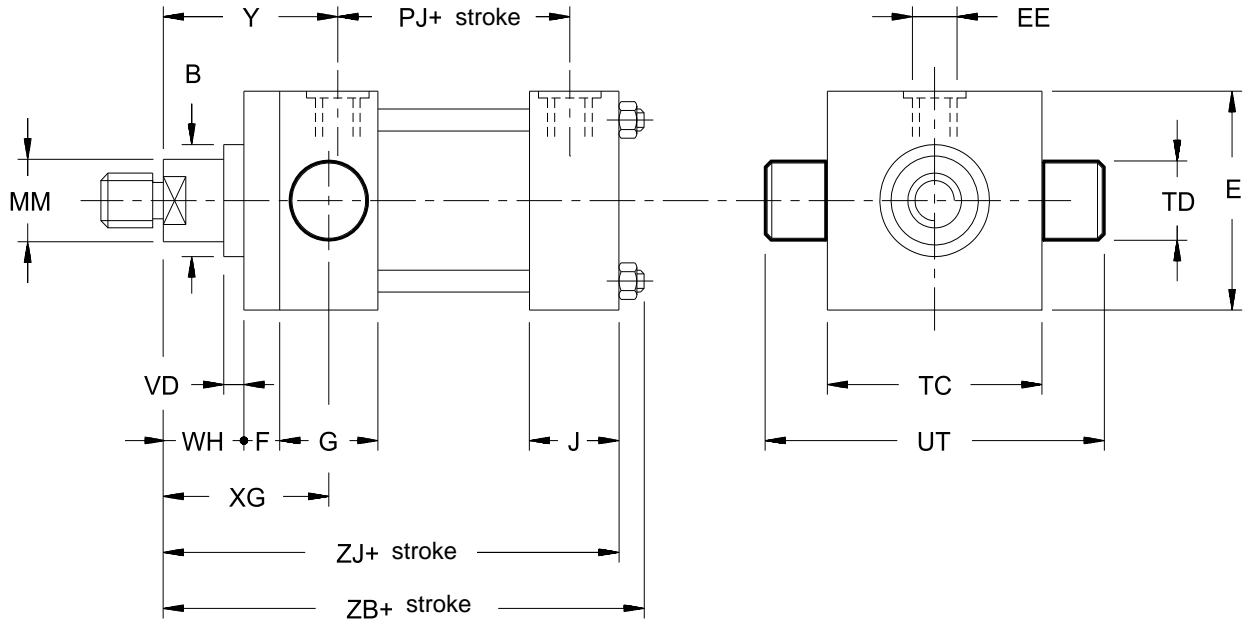

NOTE: The "E" dimension indicated in the table (bores 25 and 32) must be increased of 5 mm, only for the front end, on the oil port side (dimensions not in compliance with ISO standards).

Dimensions in mm

Bore	MM Ø rod	ØB f8	E max	EE BSP	F	G	J	PJ	ØTD f8	TC	UT	VD	WH	XG	Y	ZB	ZJ
25	12	24	40	1/4"	10	45	35	54	12	38	58	6	15	44	50	121	114
	18	30	NOTE														
32	14	26	45	1/4"	10	45	36	57	16	44	68	12	25	54	60	137	128
	18	30										6					
	22	34										12					
40	18	30	63	3/8"	10	55	45	74	20	63	95	6	25	57	62	166	153
	22	34										12					
	28	42										10					
50	22	34	75	1/2"	15	55	45	76	25	76	116	7	26	64	68	176	159
	28	42										7					
	36	50										10					
63	28	42	90	1/2"	15	55	45	80	32	89	139	7	33	70	71	185	168
	36	50										10					
	45	60										14					
80	36	50	115	3/4"	20	65	52	93	40	114	178	5	31	76	77	212	190
	45	60										9					
	56	72										9					
100	45	60	130	3/4"	-	91	55	101	50	127	207	7	35	71	82	225	203
	56	72										7					
	70	88										10					
125	56	72	165	1"	-	100	71	117	63	165	265	7	35	75	86	260	232
	70	88										10					
	90	108										10					
160	70	88	205	1"	-	111	63	130	80	203	329	7	32	75	86	279	245
	90	108										7					
	110	133										7					
200	90	108	245	1.1/4"	-	128	80	165	100	241	401	7	32	85	98	336	299
	110	133										7					
	140	163										7					

12 - OVERALL AND MOUNTING DIMENSIONS ISO/DIN MT4

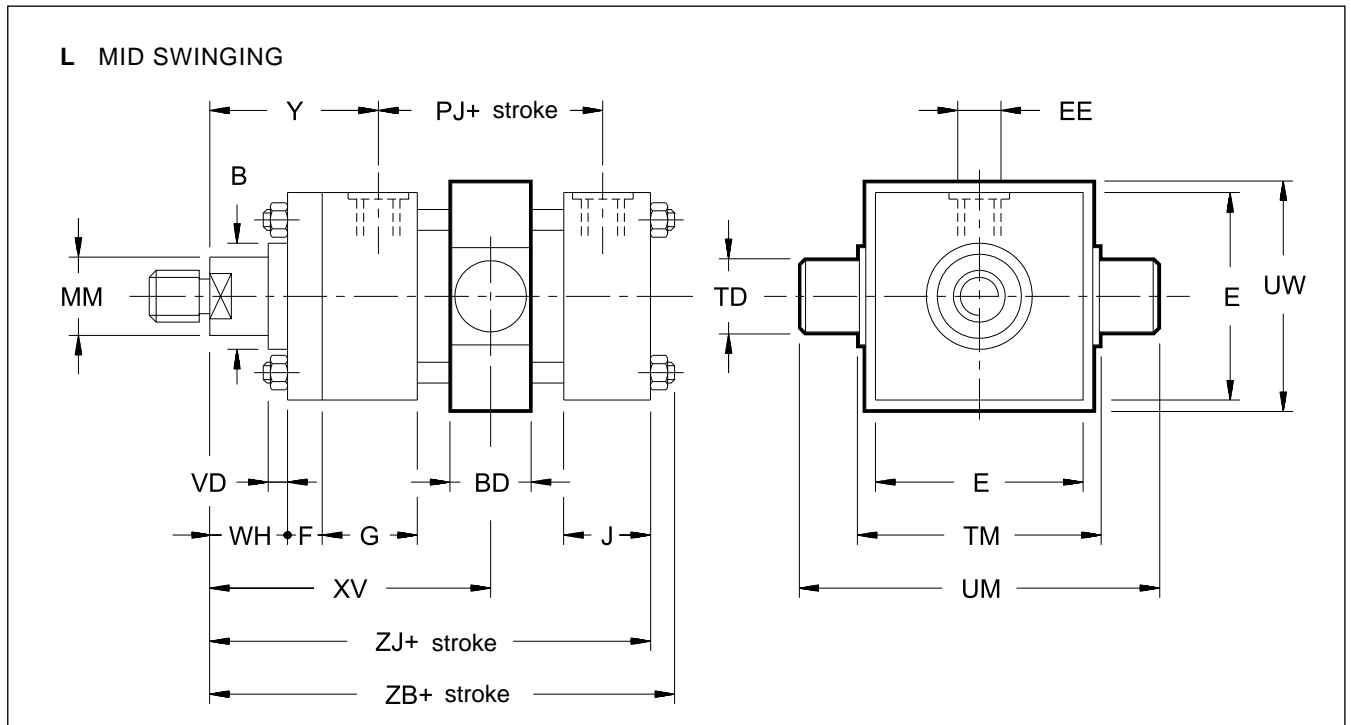

NOTE: The "E" dimension indicated in the table (bores 25 and 32) must be increased of 5 mm, only for the front end, on the oil port side (dimensions not in compliance with ISO standards).

* dimension to be defined in the order (see p. 2)

Dimensions in mm

Bore	MM Ø rod	ØB f8	BD	E max	EE BSP	F	G	J	PJ	ØTD f8	TM	UM	UW	VD	WH	XV* min	XV max + stroke	Y	ZB	ZJ	min stroke
25	12 18	24 30	20	40 NOTE	1/4"	10	45	35	54	12	48	68	45	6	15	80	69	50	121	114	11
32	14 18 22	26 30 34	25	45 NOTE	1/4"	10	45	36	57	16	55	79	50	12 6 12	25	93	79	60	137	128	13
40	18 22 28	30 34 42	30	63	3/8"	10	55	45	74	20	76	108	70	6 12 10	25	105	93	62	166	153	12
50	22 28 36	34 42 50	40	75	1/2"	15	55	45	76	25	89	129	85	7 7 10	26	116	94	68	176	159	22
63	28 36 45	42 50 60	40	90	1/2"	15	55	45	80	32	100	150	95	7 10 14	33	123	103	71	185	168	20
80	36 45 56	50 60 72	45	115	3/4"	20	65	52	93	40	127	191	120	5 9 9	31	139	115	77	212	190	23
100	45 56 70	60 72 88	60	130	3/4"	22	69	55	101	50	140	220	130	7 7 10	35	156	118	82	225	203	38
125	56 70 90	72 88 108	70	165	1"	22	78	71	117	63	178	278	170	7 10 10	35	170	126	86	260	232	44
160	70 90 110	88 108 133	90	205	1"	25	86	63	130	80	215	341	205	7	32	188	137	86	279	245	51
200	90 110 140	108 133 163	110	245	1 1/4"	25	103	80	165	100	279	439	275	7	32	215	164	98	336	299	51

13 - OVERALL AND MOUNTING DIMENSIONS ISO MT2

N REAR SWINGING

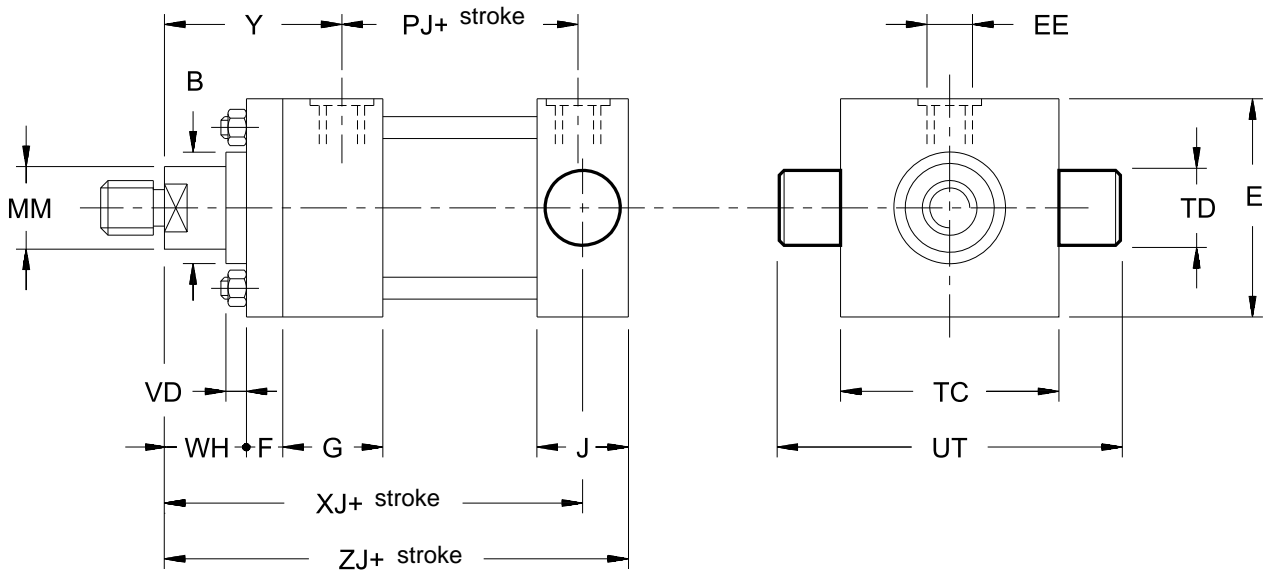

NOTE: The "E" dimension indicated in the table (bores 25 and 32) must be increased of 5 mm, only for the front end, on the oil port side (dimensions not in compliance with ISO standards).

Dimensions in mm

Bore	MM Ø rod	ØB f8	E max	EE BSP	F	G	J	PJ	ØTD f8	TC	UT	VD	WH	XJ	Y	ZJ
25	12	24	40 NOTE	1/4"	10	45	35	54	12	38	58	6	15	101	50	114
	18	30														
32	14	26	45 NOTE	1/4"	10	45	36	57	16	44	68	12	25	115	60	128
	18	30										6				
	22	34										12				
40	18	30	63	3/8"	10	55	45	74	20	63	95	6	25	134	62	153
	22	34										12				
	28	42										10				
50	22	34	75	1/2"	15	55	45	76	25	76	116	7	26	140	68	159
	28	42										7				
	36	50										10				
63	28	42	90	1/2"	15	55	45	80	32	89	139	7	33	149	71	168
	36	50										10				
	45	60										14				
80	36	50	115	3/4"	20	65	52	93	40	114	178	5	31	168	77	190
	45	60										9				
	56	72										9				
100	45	60	130	3/4"	22	69	68	101	50	127	207	7	35	187	82	216
	56	72										7				
	70	88										10				
125	56	72	165	1"	22	78	85	117	63	165	265	7	35	209	86	246
	70	88										10				
	90	108										10				
160	70	88	205	1"	25	86	95	130	80	203	329	7	32	230	86	277
	90	108										7				
	110	133										7				
200	90	108	245	1.1/4"	25	103	115	165	100	241	401	7	32	276	98	334
	110	133										7				
	140	163										7				

14 - OVERALL AND MOUNTING DIMENSIONS ISO MX1-MX2-MX3

- P FRONT TIE RODS MX3
- Q REAR TIE RODS MX2
- R FRONT AND REAR TIE RODS MX1

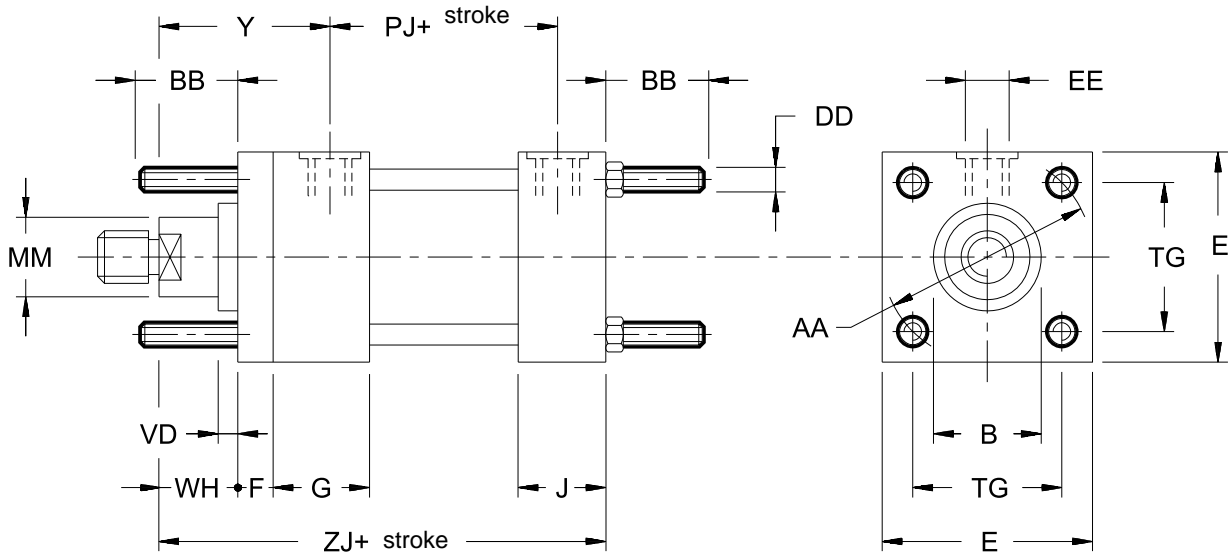

NOTE: The "E" dimension indicated in the table (bores 25 and 32) must be increased of 5 mm, only for the front end, on the oil port side (dimensions not in compliance with ISO standards).

Dimensions in mm

Bore	MM Ø rod	AA	ØB f8	BB	DD	E max	EE BSP	F	G	J	PJ	TG	VD	WH	Y	ZJ
25	12	40	24	19	M5x0.8	40	1/4"	10	45	35	54	28.3	6	15	50	114
	18		NOTE													
32	14	47	26	24	M6x1	45	1/4"	10	45	36	57	33.2	12	25	60	128
	18		NOTE			6										
	22		12													
40	18	59	30	35	M8x1	63	3/8"	10	55	45	74	41.7	6	25	62	153
	22		12													
	28		10													
50	22	74	34	46	M12x1.25	75	1/2"	15	55	45	76	52.3	7	26	68	159
	28		7													
	36		10													
63	28	91	42	46	M12x1.25	90	1/2"	15	55	45	80	64.3	7	33	71	168
	36		10													
	45		14													
80	36	117	50	59	M16x1.5	115	3/4"	20	65	52	93	82.7	5	31	77	190
	45		9													
	56		9													
100	45	137	60	59	M16x1.5	130	3/4"	22	69	55	101	96.9	7	35	82	203
	56		7													
	70		10													
125	56	178	72	81	M22x1.5	165	1"	22	78	71	117	125.9	7	35	86	232
	70		10													
	90		10													
160	70	219	88	92	M27x2	205	1"	25	86	63	130	154.9	7	32	86	245
	90		108													
	110		133													
200	90	269	108	115	M30x2	245	1.1/4"	25	103	80	165	190.2	7	32	98	299
	110		133													
	140		163													

15 - OVERALL AND MOUNTING DIMENSIONS ISO MX5

T FRONT THREADED HOLES

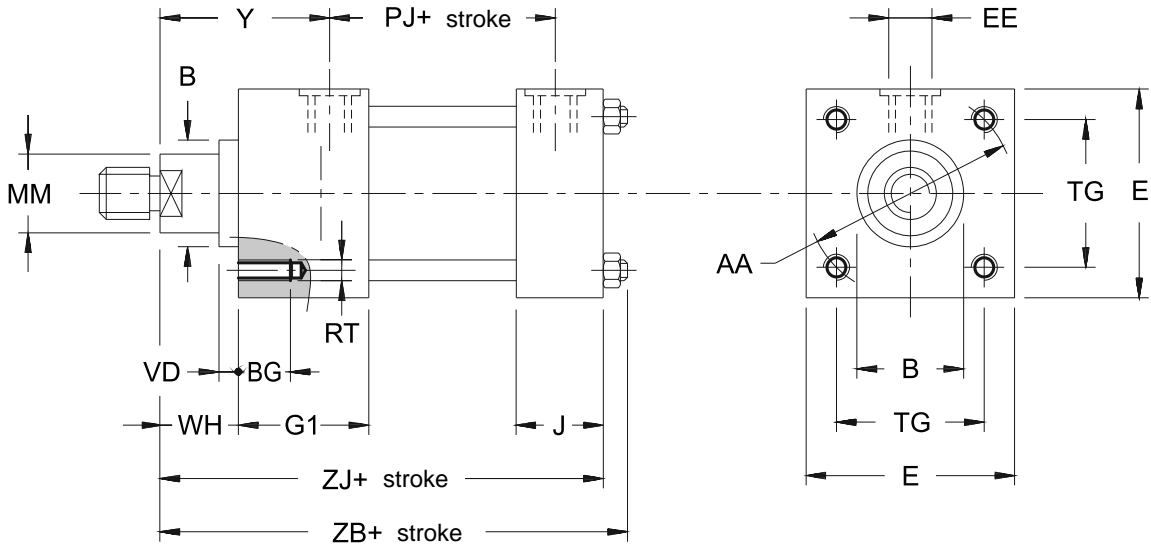

NOTE: The "E" dimension indicated in the table (bores 25 and 32) must be increased of 5 mm, only for the front end, on the oil port side (dimensions not in compliance with ISO standards).

Dimensions in mm

Bore	MM Ø rod	AA	ØB f8	BG	E max	EE BSP	G1	J	PJ	RT	TG	VD	WH	Y	ZB	ZJ
25	12 18	40	24 30	8	40 NOTE	1/4"	55	35	54	M5x0.8	28.3	6	15	50	121	114
32	14 18 22	47	26 30 34	9	45 NOTE	1/4"	55	36	57	M6x1	33.2	12 6 12	25	60	137	128
40	18 22 28	59	30 34 42	12	63	3/8"	65	45	74	M8x1.25	41.7	6 12 10	25	62	166	153
50	22 28 36	74	34 42 50	18	75	1/2"	70	45	76	M12x1.75	52.3	7 7 10	26	68	176	159
63	28 36 45	91	42 50 60	18	90	1/2"	70	45	80	M12x1.75	64.3	7 10 14	33	71	185	168
80	36 45 56	117	50 60 72	24	115	3/4"	85	52	93	M16x2	82.7	5 9 9	31	77	212	190
100	45 56 70	137	60 72 88	24	130	3/4"	91	55	101	M16x2	96.9	7 7 10	35	82	225	203
125	56 70 90	178	72 88 108	27	165	1"	100	71	117	M22x2.5	125.9	7 10 10	35	86	260	232
160	70 90 110	219	88 108 133	32	205	1"	111	63	130	M27x3	154.9	7	32	86	279	245
200	90 110 140	269	108 133 163	40	245	1 1/4"	128	80	165	M30x3.5	190.2	7	32	98	336	299

16 - OVERALL AND MOUNTING DIMENSIONS ISO MX6

U REAR THREADED HOLES

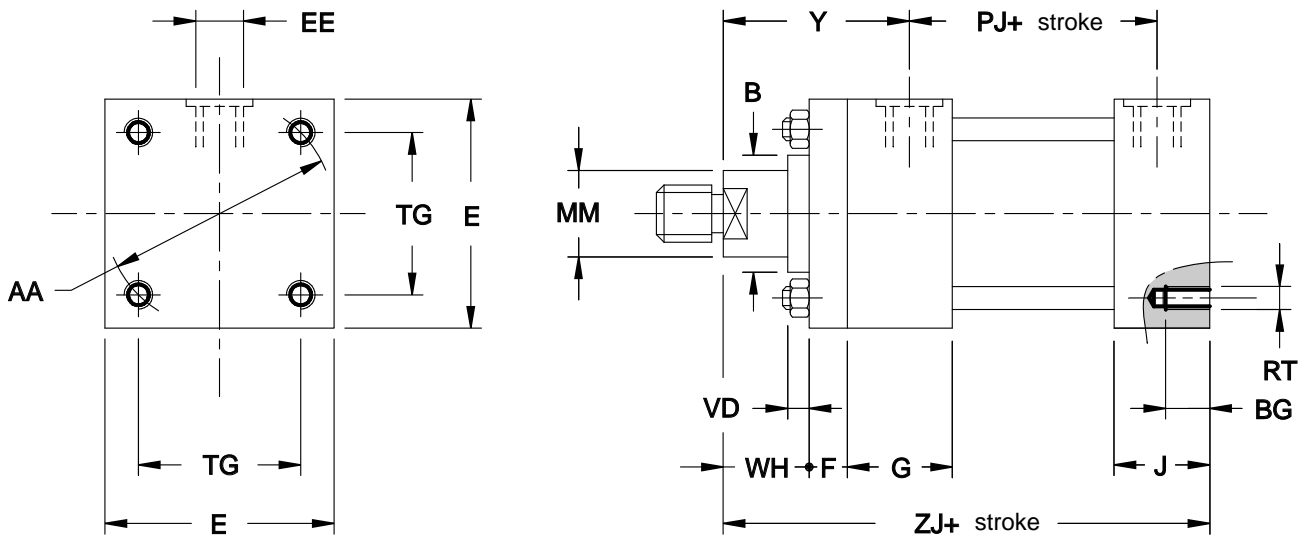

NOTE: The "E" dimension indicated in the table (bores 25 and 32) must be increased of 5 mm, only for the front end, on the oil port side (dimensions not in compliance with ISO standards).

Dimensions in mm

Bore	MM Ø rod	AA	ØB f8	BG	E max	EE BSP	F	G	J	PJ	RT	TG	VD	WH	Y	ZJ
25	12 18	40	24 30	8	40 NOTE	1/4"	10	45	35	54	M5x0.8	28.3	6	15	50	114
32	14 18 22	47	26 30 34	9	45 NOTE	1/4"	10	45	36	57	M6x1	33.2	12 6 12	25	60	128
40	18 22 28	59	30 34 42	12	63	3/8"	10	55	45	74	M8x1.25	41.7	6 12 10	25	62	153
50	22 28 36	74	34 42 50	18	75	1/2"	15	55	45	76	M12x1.75	52.3	7 7 10	26	68	159
63	28 36 45	91	42 50 60	18	90	1/2"	15	55	45	80	M12x1.75	64.3	7 10 14	33	71	168
80	36 45 56	117	50 60 72	24	115	3/4"	20	65	52	93	M16x2	82.7	5 9 9	31	77	190
100	45 56 70	137	60 72 88	24	130	3/4"	22	69	55	101	M16x2	96.9	7 7 10	35	82	203
125	56 70 90	178	72 88 108	27	165	1"	22	78	71	117	M22x2.5	125.9	7 10 10	35	86	232
160	70 90 110	219	88 108 133	32	205	1"	25	86	63	130	M27x3	154.9	7	32	86	245
200	90 110 140	269	108 133 163	40	245	1.1/4"	25	103	80	165	M30x3.5	190.2	7	32	98	299

17 - OVERALL AND MOUNTING DIMENSIONS

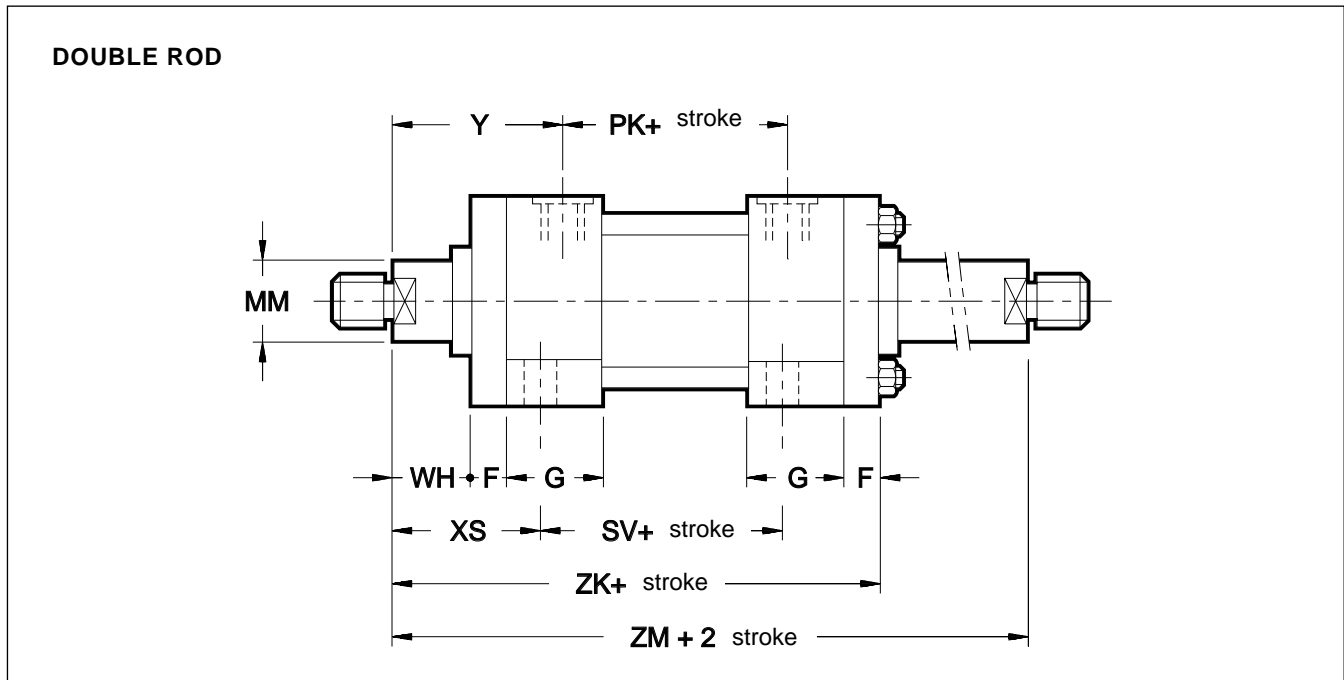

Dimensions in mm

For other dimensions and mounting styles please see single rod cylinder tables.
Not available for mounting styles B-C-D-F-N-Q-U

NOTE: Double rod cylinders are developed with two separate rods, fixed together by means of threading. Because of this mounting style, the rod with female threading is less resistant than the other.

To simplify the identification of the more resistant rod, the "M" marking is stamped on its end.

We recommend the use of the weaker rod for the less demanding applications.

Bore	MM Ø rod	F	G	PK	SV	WH	XS	Y	ZM	ZK
25	12 18	10	45	49	88	15	33	50	154	134
32	14 18 22	10	45	52	88	25	45	60	178	147
40	18 22 28	10	55	74	105	25	45	62	195	173
50	22 28 36	15	55	76	99	26	54	67	207	184
63	28 36 45	15	55	84	93	33	65	71	223	193
80	36 45 56	20	65	100	110	31	68	77	246	223
100	45 56 70	22	69	110	107	35	79	82	265	239
125	56 70 90	22	78	124	131	35	79	86	288	261
160	70 90 110	25	86	130	130	32	86	86	302	270
200	90 110 140	25	103	160	172	32	92	98	356	324

18 - ROD DIAMETER SELECTION

To ensure adequate stability, cylinders must be calculated for maximum compressive load according to the following simplified procedure:

- Refer to the table to identify the stroke factor according to the mounting style.
- To calculate the reference length, multiply the working stroke by the stroke factor.

- To calculate the thrust force, multiply the total cylinder area by the operating pressure.
- On the diagram, find the point of intersection between the thrust force and reference length.
- Identify the minimum rod diameter on the curve above the previous point of intersection.

Cylinders with rod diameters smaller than the value plotted in the diagram will not guarantee sufficient rigidity.

Mounting style	Rod connection	Mounting	Stroke factor
A-P-R-T	Fixed and supported		2
	Fixed and rigidly guided		0.5
	Jointed and rigidly guided		0.7
B-Q-U	Fixed and supported		4
	Fixed and rigidly guided		1
	Jointed and rigidly guided		1.5
H	Jointed and rigidly guided		1

Mounting style	Rod connection	Mounting	Stroke factor
C-D-F-N	Jointed and supported		4
	Jointed and rigidly guided		2
G	Fixed and supported		2
	Fixed and rigidly guided		0.5
	Jointed and rigidly guided		0.7
L	Jointed and supported		3
	Jointed and rigidly guided		1.5

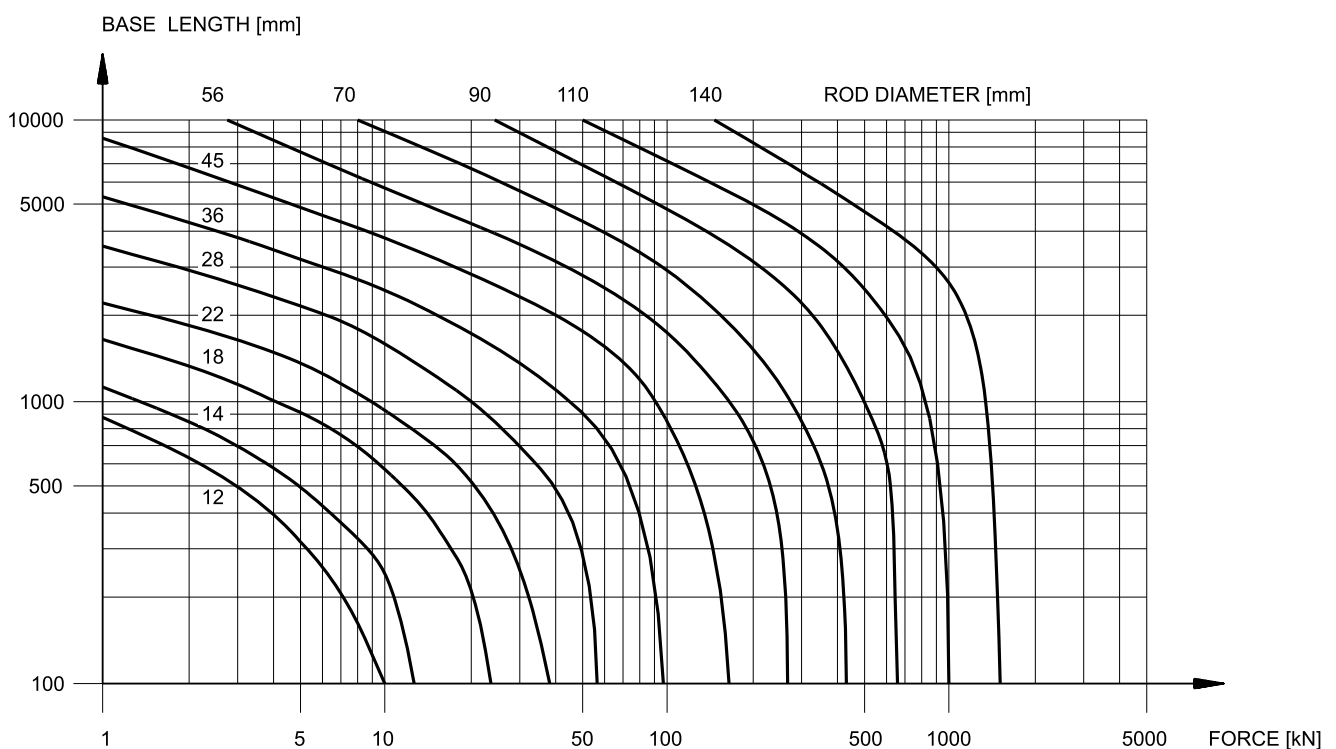

19 - THEORETICAL FORCES

Push force

$$F_s = P \cdot A_t$$

Pull force

$$F_t = P \cdot A_a$$

F_s = Force (extension) in N

F_t = Force (retraction) in N

A_t = Total area in mm^2

A_a = Annular area in mm^2

P = Pressure in MPa

1 bar = 0.1 MPa

1 kgf = 9.81 N

Bore mm	Ø rod mm	Total area mm^2	Annular area mm^2
25	12	491	378
	18		236
32	14	804	650
	18		550
	22		424
40	18	1 257	1 002
	22		876
	28		641
50	22	1 964	1 583
	28		1 348
	36		946
63	28	3 117	2 502
	36		2 099
	45		1 527
80	36	5 027	4 009
	45		3 437
	56		2 564
100	45	7 854	6 264
	56		5 391
	70		4 006
125	56	12 272	9 809
	70		8 424
	90		5 910
160	70	20 106	16 258
	90		13 744
	110		10 603
200	90	31 416	25 054
	110		21 913
	140		16 022

20 - THEORETICAL VELOCITY

Configuration 1

The diagram illustrates a conventional cylinder application: the fluid is delivered by means of a directional control valve in alternation to the front chamber while the rear chamber is connected to tank and vice versa.

To calculate velocity and force, proceed as follows:

Velocity (extension) $V = \frac{Q \cdot 1000}{A_t \cdot 60}$

Velocity (retraction) $V = \frac{Q \cdot 1000}{A_a \cdot 60}$

Force (extension) $F = P \cdot A_t$

Force (retraction) $F = P \cdot A_a$

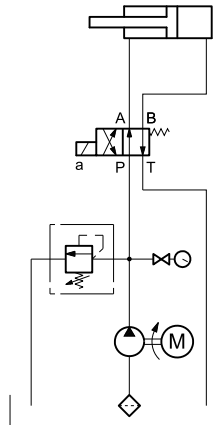

V = Velocity in m/s

Q = Flow rate in l/min

A_t = Total area (piston bore) in mm^2

A_a = Annular area ($A_t - A_s$) in mm^2

F = Force in N

P = Pressure in MPa

A_s = Rod area ($A_t - A_a$) in mm^2

Q_d = Flow rate through directional control valve (Q +return flow rate from small chamber) in l/min

1 bar = 0.1 MPa

1 kgf = 9.81 N

Configuration 2

When the system requires high velocity with relatively low forces, we recommend using a regenerative circuit. The diagram 2 illustrates the simplest version of this type of set-up.

The annular chamber is permanently connected to the pump while the full bore end is connected alternately to the pump, in which case the piston rod extends as a result of the differential areas (both chambers are supplied at the same pressure), and to tank, in which case the piston rod retracts.

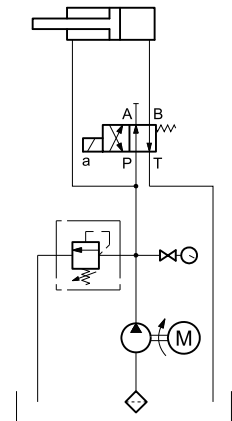

Velocity (extension) $V = \frac{Q \cdot 1000}{A_s \cdot 60}$

Velocity (retraction) $V = \frac{Q \cdot 1000}{A_a \cdot 60}$

Force (extension) $F = P \cdot A_s$

Force (retraction) $F = P \cdot A_a$

NOTE: In regenerative circuits, the sizing of the directional control valve is fundamental. Flow rate through the directional control valve is calculated according to the following formula:

$$Q_d = \frac{V \cdot A_t \cdot 60}{1000}$$



21 - MASSES

Bore	Ø rod	Mass for null stroke						Mass for 10 mm stroke
		Mounting style						
		P-Q-R-T-U	G	A-B	C-D-F	H-N	L	
mm	mm	kg	kg	kg	kg	kg	kg	kg
25	12	1.2	1.3	1.4	1.4	1.4	1.5	0.04
	18	1.2	1.3	1.4	1.4	1.4	1.5	0.06
32	14	1.6	1.8	1.9	1.9	1.7	1.9	0.06
	18	1.6	1.8	1.9	1.9	1.7	1.9	0.07
	22	1.7	1.8	1.9	1.9	1.7	1.9	0.08
40	18	3.7	3.9	4.6	4.2	3.9	4.6	0.1
	22	3.7	3.9	4.6	4.2	3.9	4.6	0.11
	28	3.8	4	4.7	4.3	4	4.7	0.12
50	22	5.9	6.4	7.1	7.1	6.3	7.9	0.14
	28	6	6.5	7.2	7.2	6.4	8	0.17
	36	6.1	6.6	7.3	7.3	6.5	8.1	0.18
63	28	8.5	9.7	10	10.1	8.8	10.5	0.19
	36	8.6	9.8	10.1	10.3	8.9	10.6	0.22
	45	8.7	9.9	10.2	10.4	9.1	10.7	0.26
80	36	16	17.2	18.8	19.5	16.6	19	0.27
	45	16.2	17.4	19	19.6	16.7	20	0.32
	56	16.3	17.6	19.1	19.8	16.9	22	0.39
100	45	22	23	25	28.1	22.8	26	0.4
	56	22.5	24	25.5	28.5	23.1	27	0.48
	70	23	25	26	29	23.4	28	0.58
125	56	41.5	44	47.5	53	42.5	48	0.65
	70	42.5	44.5	48	54	43	49	0.76
	90	44	45	49	55	44	50	0.96
160	70	69	72	79	89.5	71	84	1
	90	70	73	80	91	72	85	1.2
	110	71	74	81	92	72.5	86	1.4
200	90	122	128.5	137	157	127	152	1.6
	110	123	129.5	139	158	128.5	153	1.8
	140	124	131	140	159	129.5	155	2.2

22 - END-STROKE PROXIMITY SENSORS

On request, cylinders can be supplied with end-stroke proximity sensors type PNP, with normally open output. They are mounted on the front and rear end of the cylinder and they supply an electric signal when the piston rod reaches the stroke end.

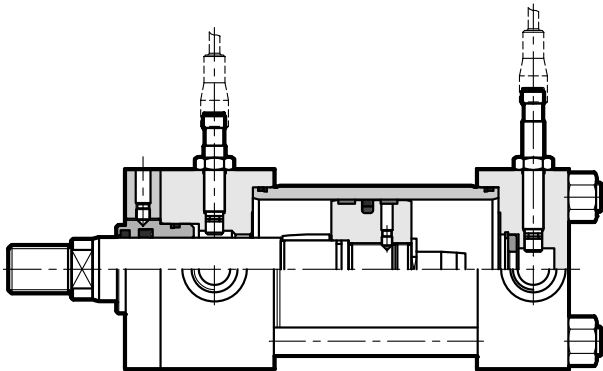

They are available for all cylinder mounting styles, from Ø40, with the following limits:

bore Ø40:

mounting A-H available on rear end only
 mounting B-N available on front end only

bore Ø50:

mounting H available on rear end only
 mounting N available on front end only

bores Ø80 and Ø100:

mounting N available on front end only

bores Ø125/56, Ø160 and Ø200:

mounting A available on rear end only
 mounting B available on front end only

In order to ensure the correct functioning of the system, cylinders must be equipped with cushionings.

These sensors can be only used to provide the switching signal and not to control voltage loads.

22.1 - Identification code

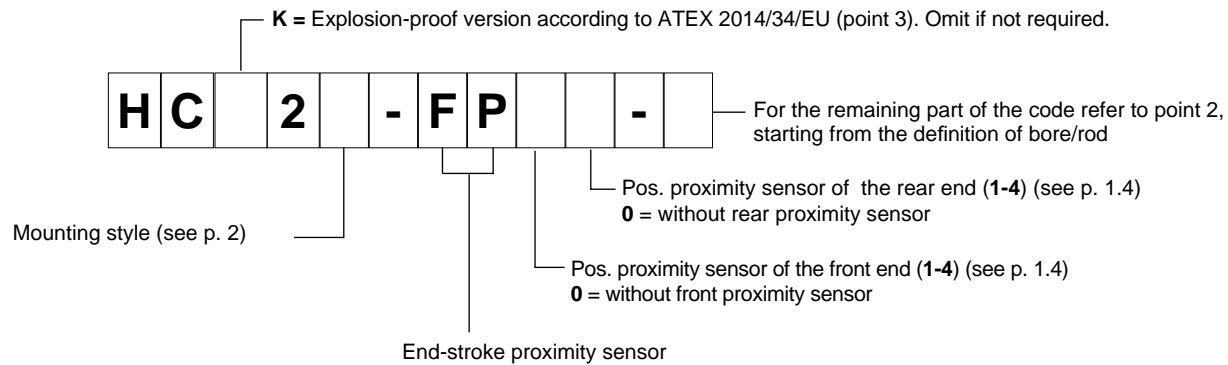

22.2 - Technical characteristics and electrical connection

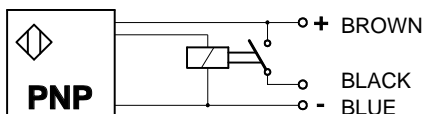

Rated voltage	VDC	24
Power supply voltage range	VDC	10 ÷ 30
Absorbed current	mA	200
Output	normally open contact	
Electric protection	polarity inversion short circuit overvoltage	
Electric connection	with connector	
Maximum operating pressure	bar	500
Operating temperature range	°C	-25 / +80
Class of protection according IEC EN 60529 (atmospheric ag.)	IP68	
Piston position LED (NOTE)	NO (it's on the connector)	

22.3 - Connectors (to be ordered separately)

NOTE: These connectors are not suitable for ATEX-rated cylinders. The connectors for the ATEX-rated cylinders are described at point 3.5.

Code: **ECM3S/M12L/10/L5**

Connector: pre-wired connector M12 - IP68
 Cable: with 3 conductors 0.34 mm² - length 5 mt.
 Cable material: polyurethane resin (oil resistant)

LED indication:

The connector has two LEDs, one green and one yellow.

GREEN: Connector power supply.
 The LED lights up when the connector is powered.

YELLOW: position signal.
 ON - piston at stroke end
 OFF - piston not at stroke end

23 - MAGNETIC END-STROKE SENSORS

Upon request, cylinders can be supplied with adjustable magnetic sensors, mounted on tie rods, which allow the reading in every position of the piston, both intermediate and end stroke. The "switching zone" of these sensors can reach about 30 ÷ 40 mm, depending on piston speed and cylinder bore. Therefore, if the Client needs to read with precision only the signal of the stroke end, and not of other positions, we recommend the use of end-stroke proximity sensors (see p. 22), rather than magnetic sensors.

Magnetic sensors are available for bores Ø 25 to Ø 125 included. For cylinders with strokes under 80 mm and for cylinders with mid swinging mounting type, we recommend to consult our technical office, because, in some applications, magnetization problems of cylinder parts could happen, affecting the correct functioning of the system.

Cylinders are supplied with 2 magnetic sensors, already mounted on tie rods, which can be of two types:

- Reed magnetic sensors (**standard**): they are sensors with normally open contact, which commute exploiting the magnetic field generated by the plastoferrite ring inserted in the piston. They have a long electric life and a switching power which allows to control voltage loads directly.
- Magnetic sensors with Hall effect: they are sensors which read the voltage variation generated by the piston movement, by means of a normally open electronic semiconductor type PNP. Because of the absence of moving parts inside the sensors, they guarantee a much longer electric life than that of Reed sensors, a high sensitivity and switching reliability. As opposed to Reed sensors, these sensors can be used only to provide the switching signal and not to control voltage loads.

23.1 - Identification code

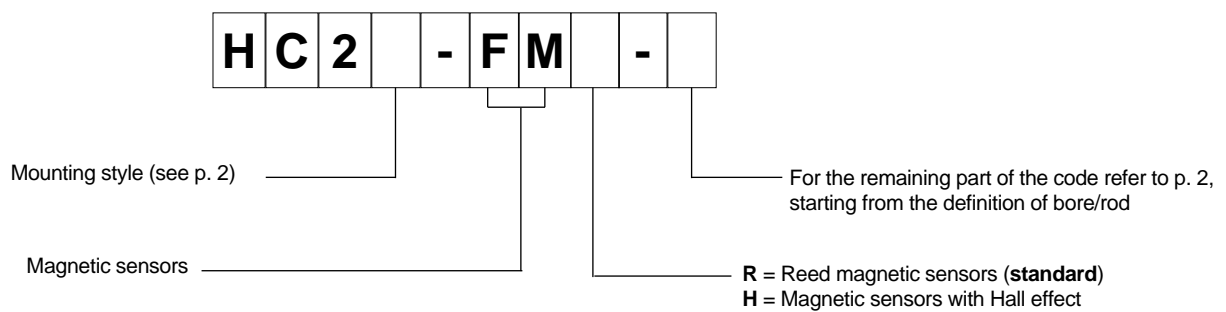

23.2 - Mounting and overall dimensions

Reed sensors for Ø 25 and Ø 32 bore and sensors with Hall effect

1	Bracket fastening screw
2	Socket for fastening to the tie rod
3	Bracket for fastening to the tie rod
4	Sensor fastening screw
5	Magnetic sensor

Reed sensors for Ø 40 ÷ Ø 125 bore

23.3 - Technical Characteristics And Electrical Connection

Reed sensors (FMR)

		Reed sensor without connector (for 25 and 32 bores)	Reed sensor with connector (for 40, 50, 63, 80, 100 and 125 bores)
Sensor version		Reed	Reed
Contact		normally open	normally open
Maximum power	W	20	50
Maximum voltage	V AC/DC	130	250
Minimum voltage	V AC/DC	3	3
Voltage drop	V	2,5	2,5
Maximum power	mA	300	1000
Wiring		2 cables	2 cables
Connection		cable (L = 2 m)	connector (with cable L = 2 m)
Cable section	mm ²	0,25	0,25
Varistor	V	-	250
Sheath material		PVC	PVC
Contact indicator		red led	red led
Operating temperature range	°C	-20 / +80	-20 / +80

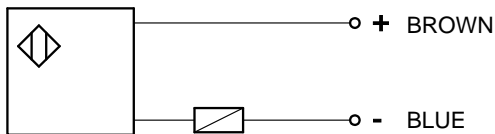

Hall effect sensors (FMH)

Sensor version		Hall effect
Contact		normally open
Sensor type		PNP
Maximum voltage	V AC/DC	30
Minimum voltage	V AC/DC	10
Voltage drop	V	0,5
Maximum power	mA	200
Wiring		3 cables
Connection		cable (L = 2 m)
Cable section	mm ²	0,14
Wire covering material		PVC
Contact indicator		red led
Operating temperature range	°C	-20 / +80

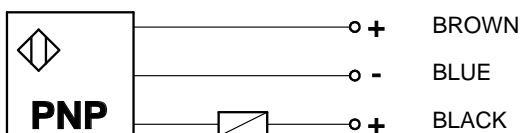

24 - OVERALL AND MOUNTING DIMENSIONS

SPHERICAL SWIVEL ISO 8133 / DIN 24555

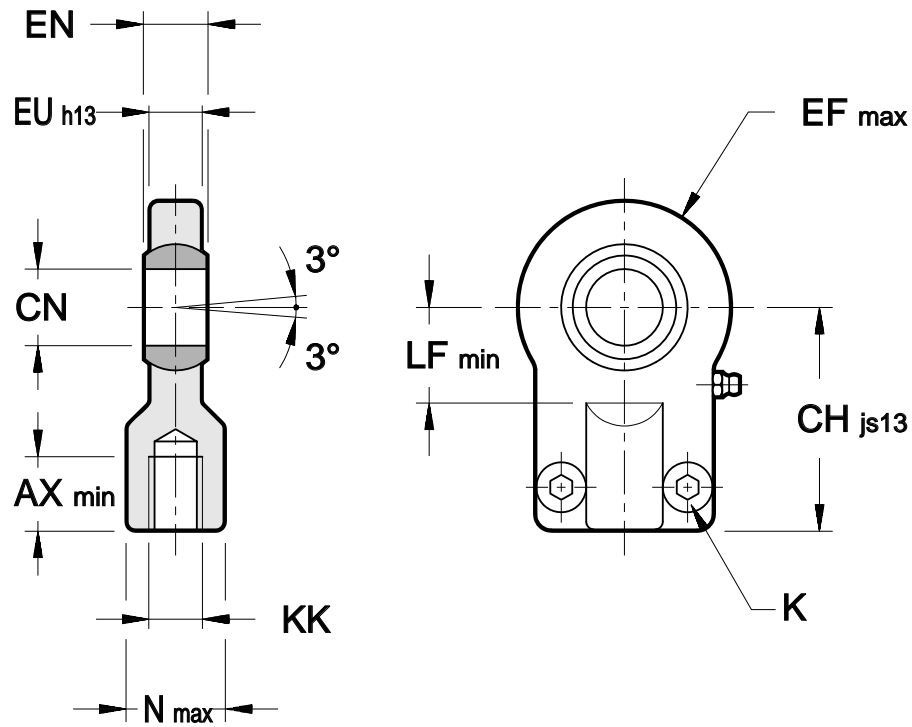

NOTE: no lubricator on SSF-12. On SSF-14 and SSF-18 sizes the injection of the lubricant takes place through a hole.

Dimensions in mm

Type	Ø cylinder rod		AX min	CH js13	Ø CN	EF max	EN	EU h13	KK	LF min	N max	K bolt UNI 5931	Torque Nm	Max load kN	Mass kg
	standard thread	light thread													
SSF-12	12	18	15	42	12 ⁰ _{-0.008}	20	10 ⁰ _{-0.12}	8	M10x1.25	16	17	M6x14	10	8	0.2
SSF-14	14	22	17	48	16 ⁰ _{-0.008}	22.5	14 ⁰ _{-0.12}	11	M12x1.25	20	21	M6x14	10	12.5	0.3
SSF-18	18	28	19	58	20 ⁰ _{-0.010}	27.5	16 ⁰ _{-0.12}	13	M14x1.5	25	25	M8x18	25	20	0.4
SSF-22	22	36	23	68	25 ⁰ _{-0.010}	32.5	20 ⁰ _{-0.12}	17	M16x1.5	30	30	M8x18	25	32	0.7
SSF-28	28	45	29	85	30 ⁰ _{-0.010}	40	22 ⁰ _{-0.12}	19	M20x1.5	35	36	M10x20	49	50	1.2
SSF-36	36	56	37	105	40 ⁰ _{-0.012}	50	28 ⁰ _{-0.12}	23	M27x2	45	45	M10x25	49	80	2.2
SSF-45	45	70	46	130	50 ⁰ _{-0.012}	62.5	35 ⁰ _{-0.12}	30	M33x2	58	55	M12x30	86	125	4.2
SSF-56	56	90	57	150	60 ⁰ _{-0.015}	80	44 ⁰ _{-0.15}	38	M42x2	68	68	M16x40	210	200	8.3
SSF-70	70	110	64	185	80 ⁰ _{-0.015}	102.5	55 ⁰ _{-0.15}	47	M48x2	92	90	M20x50	410	320	19
SSF-90	90	140	86	240	100 ⁰ _{-0.020}	120	70 ⁰ _{-0.20}	57	M64x3	116	110	M24x60	710	500	28

25 - OVERALL AND MOUNTING DIMENSIONS

SPHERICAL SWIVEL ISO 6982 / DIN 24338

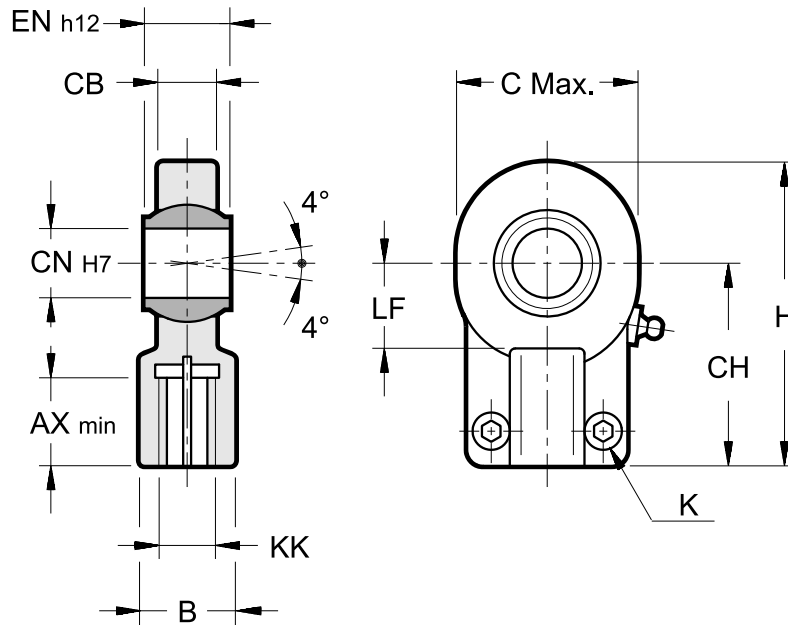

NOTE: no lubricator on LSF-14. On LSF-18 the injection of the lubricant takes place through a hole.

Dimensions in mm

Type	Ø rod		AX min	B	C max	CB	CH	Ø CN		H	KK	LF	K bolt UNI 5931	Torque Nm	Max load kN	Mass kg
	standard thread	light thread						H7	h12							
LSF-14	14	22	17	16	32	11	38	12	12	54	M12x1.25	14	M5x16	6	10.8	0.10
LSF-18	18	28	19	21	40	14	44	16	16	64	M14x1.5	20	M6x14	10	17.6	0.21
LSF-22	22	36	23	25	47	18	52	20	20	75	M16x1.5	22	M8x20	25	30	0.35
LSF-28	28	45	29	30	58	22	65	25	25	96	M20x1.5	27	M8x20	25	48	0.62
LSF-36	36	56	37	38	71	28	80	32	32	119	M27x2	32	M10x25	49	67	1.17
LSF-45	45	70	46	47	90	33	97	40	40	146	M33x2	41	M10x30	49	100	2.15
LSF-56	56	90	57	58	109	41	120	50	50	180	M42x2	50	M12x35	86	156	3.75
LSF-70	70	110	64	70	132	53	140	63	63	212	M48x2	62	M16x40	210	255	7.00
LSF-90	90	140	86	90	170	67	180	80	80	271	M64x3	78	M20x50	410	400	13.8

26 - OVERALL AND MOUNTING DIMENSIONS

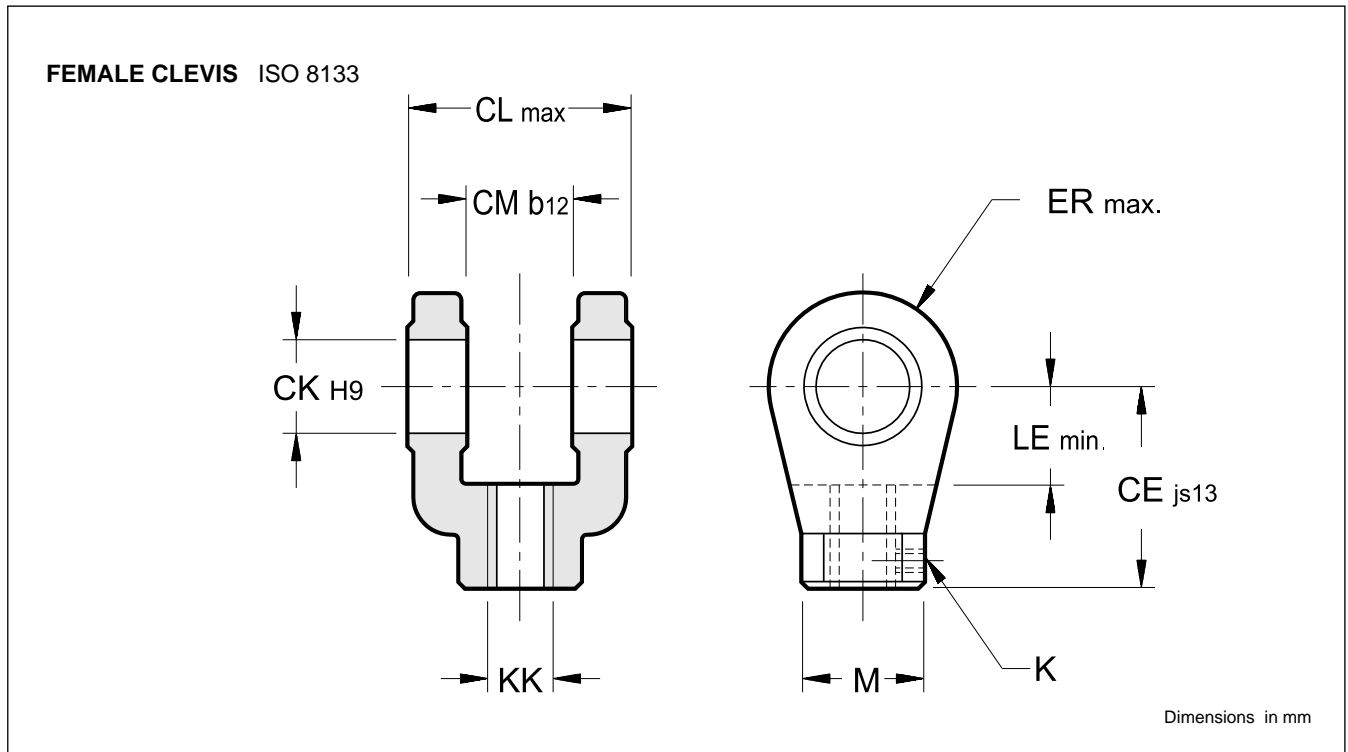

Type	Ø cylinder rod		M	CE	Ø CK		CL	CM	ER	KK	LE	K bolt	Max load kN	Mass kg
	standard thread	light thread			CH	js13								
FRC-12	12	18	19	32	10	26	12	12	M10x1.25	13	M5x5	8	0.1	
FRC-14	14	22	21	36	12	34	16	17	M12x1.25	19	M5x5	12.5	0.2	
FRC-18	18	28	21	38	14	42	20	17	M14x1.5	19	M5x5	20	0.2	
FRC-22	22	36	32	54	20	62	30	29	M16x1.5	32	M6x6	32	0.5	
FRC-28	28	45	32	60	20	62	30	29	M20x1.5	32	M6x6	50	1	
FRC-36	36	56	40	75	28	83	40	34	M27x2	39	M6x6	80	1.8	
FRC-45	45	70	55	99	36	103	50	50	M33x2	54	M8x8	125	3.7	
FRC-56	56	90	56	113	45	123	60	53	M42x2	57	M8x8	200	5.6	
FRC-70	70	110	75	126	56	143	70	59	M48x2	63	M12x12	320	9.3	
FRC-90	90	140	95	168	70	163	80	78	M64x3	83	M12x12	500	20	

27 - OVERALL AND MOUNTING DIMENSIONS

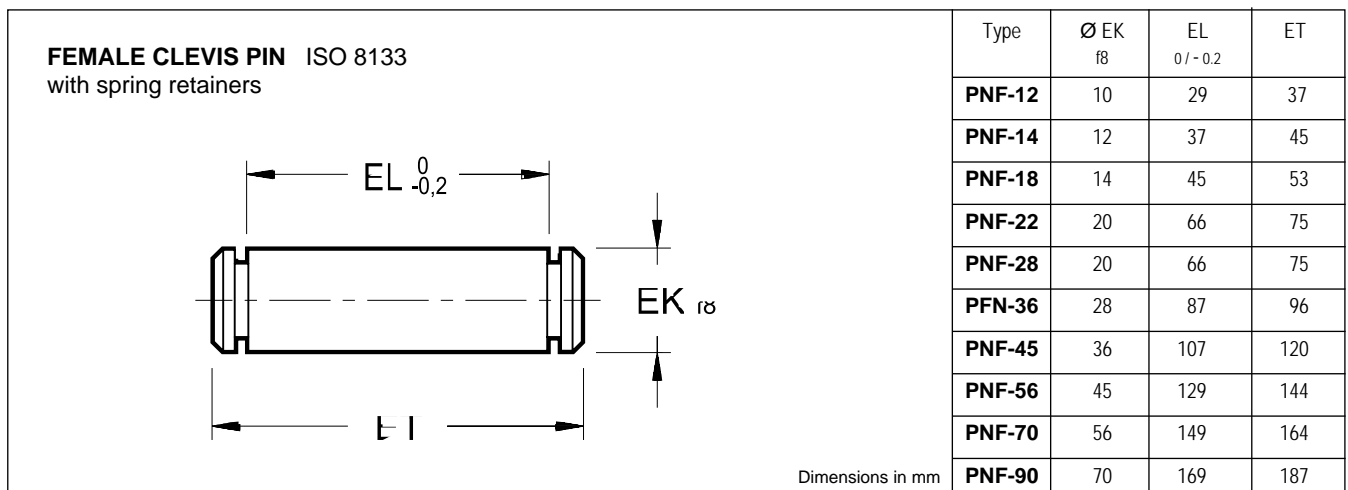

Type	Ø EK r8	EL 0 / -0.2	ET
PNF-12	10	29	37
PNF-14	12	37	45
PNF-18	14	45	53
PNF-22	20	66	75
PNF-28	20	66	75
PNF-36	28	87	96
PNF-45	36	107	120
PNF-56	45	129	144
PNF-70	56	149	164
PNF-90	70	169	187

28 - OVERALL AND MOUNTING DIMENSIONS

FEMALE CLEVIS FLANGE FOR SPHERIC SWIVEL DIN 24554 (with PIN and spring retainers)

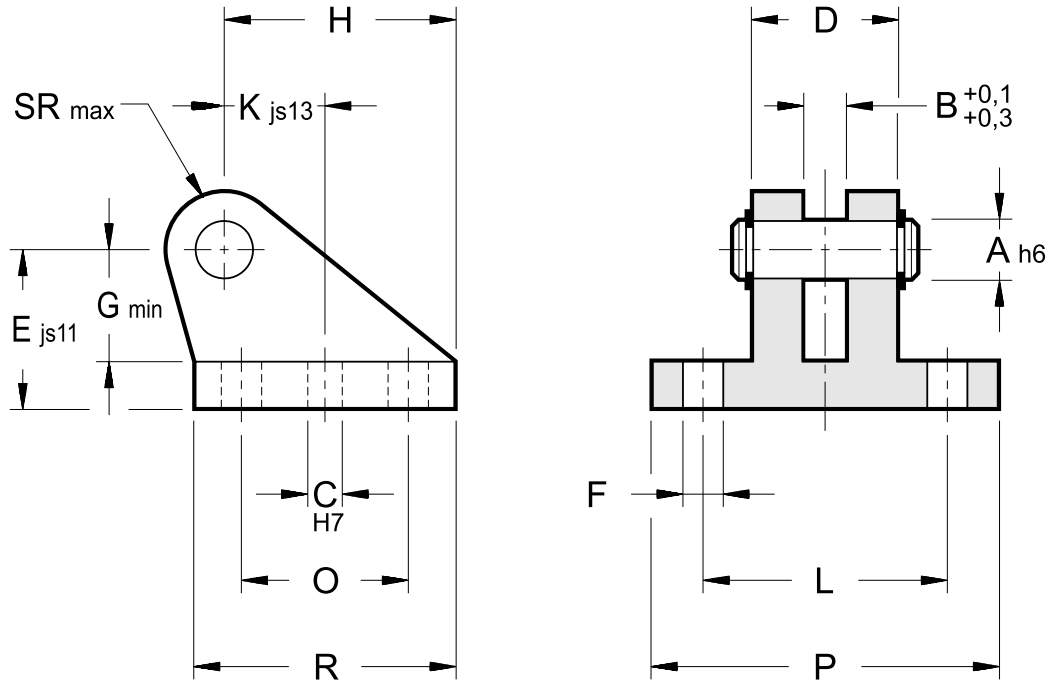

Dimensions in mm

Type	Cylinder bore	ØA h6	B $+0.1$ $+0.3$	ØC H7	D	E js11	ØF	G min	H	K js13	L	O	P	R	SR max	Max load kN	Mass kg
FLF-25	25	12	10	8	30	40	9	28	56	26	55	40	75	60	12	8	0.5
FLF-32	32	16	14	10	40	50	11	37	74	34	70	55	95	80	16	12.5	1
FLF-40	40	20	16	12	50	55	14	39	80	35	85	58	120	90	20	20	1.7
FLF-50	50	25	20	12	60	65	16	48	98	43	100	70	140	110	25	32	2.7
FLF-63	63	30	22	16	70	85	18	62	120	52	115	90	160	135	30	50	5.2
FLF-80	80	40	28	20	80	100	22	72	148	63	135	120	190	170	40	80	9.3
FLF-100	100	50	35	25	100	125	30	90	190	82	170	145	240	215	50	125	18.5
FLF-125	125	60	44	40	120	150	39	108	225	95	200	185	270	260	60	200	35
FLF-160	160	80	55	40	160	190	45	140	295	125	240	260	320	340	80	320	63
FLF-200	200	100	70	45	200	210	48	150	335	135	300	300	400	400	100	500	110

29 - OVERALL AND MOUNTING DIMENSIONS

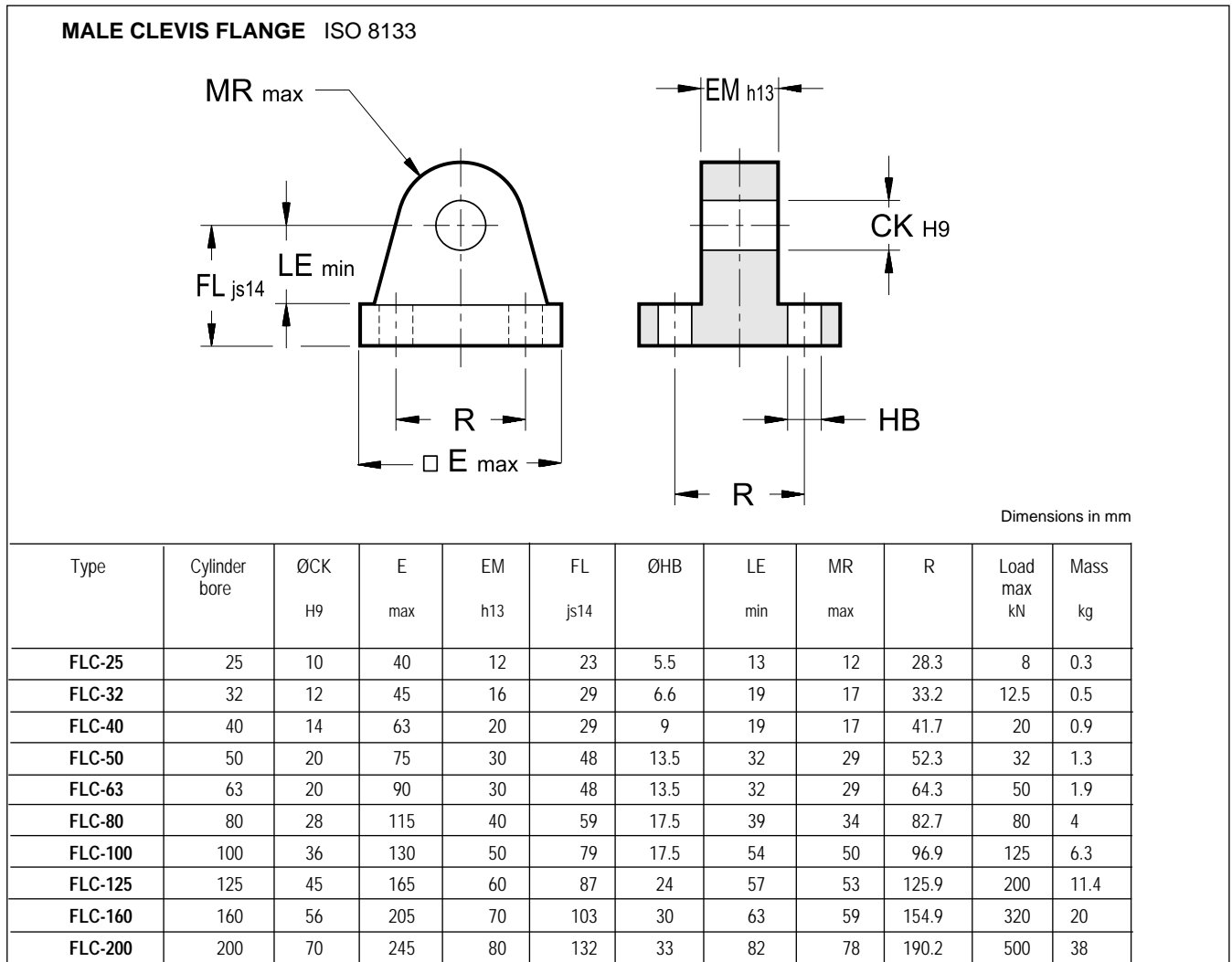

30 - SEAL KIT IDENTIFICATION CODE

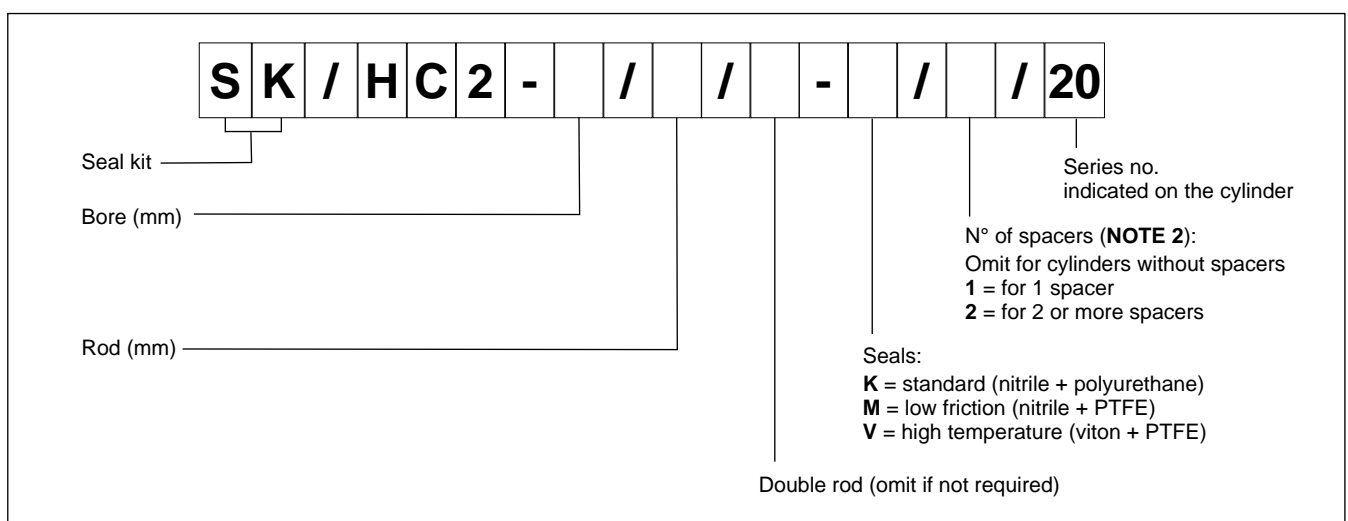

NOTE 1: the seal kit includes all the seals of a cylinder with cushionings.

NOTE 2: To determine the number of spacers fitted in the cylinder, see the cylinder plate and the identification code on page 3.



HC2
SERIES 20

DUPLOMATIC
MOTION SOLUTIONS
*a member of **DAIKIN** group*

DUPLOMATIC MS Spa

via Mario Re Depaolini, 24 | 20015 Parabiago (MI) | Italy
T +39 0331 895111 | E vendite.ita@duplomatic.com | sales.exp@duplomatic.com
duplomaticmotionsolutions.com