

DZCE*K*

EXPLOSION-PROOF PRESSURE REDUCING VALVE WITH PROPORTIONAL CONTROL ATEX, IECEx, PESO SERIES 30

DZCE5K* **CETOP P05**
DZCE5RK* **ISO 4401-05**
DZCE7K* **ISO 4401-07**
DZCE8K* **ISO 4401-08**

OPERATING PRINCIPLE

- The DZCE*K* are explosion-proof pressure reducing valves, pilot operated, with proportional control, available with CETOP P05, ISO 4401-05, ISO 4401-07 and ISO 4401-08 mounting surfaces.
- They are compliant with ATEX, IECEx and PESO requirements and are suitable for use in potentially explosive atmospheres, for surface plants or mines.
- A low temperature version (up to -40 °C) is also available.
- They can be controlled directly by a current control supply unit or combined with an external electronic card to maximize the valve performances (see p. 16).
- Upon request, DZCE*K* valves can be supplied with a finishing surface treatment (zinc-nickel) which is suitable to ensure a salt spray resistance up to 600 hours.
- **Details for classification, operating temperatures and electrical characteristics are in the technical data sheet 02 500 'Explosion proof classification'.**

PERFORMANCES

(obtained with mineral oil with viscosity of 36 cSt at 50°C)

		DZCE5K* DZCE5RK*	DZCE7K*	DZCE8K*
Maximum operating pressure	bar	350		
Maximum flow	l/min	150	300	500
Step response		see point 5		
Hysteresis (with PWM 200 Hz)	% of p _{max}	< 6%		
Repeatability	% of p _{max}	< ±2%		
Electrical characteristic		see point 6		
Temperature ranges (ambient and fluid)		see data sheet 02 500		
Fluid viscosity range	cSt	10 ÷ 400		
Fluid contamination degree		According to ISO 4406:1999 class 18/16/13		
Recommended viscosity	cSt	25		
Mass	kg	5.6	8.2	15

HYDRAULIC SYMBOL

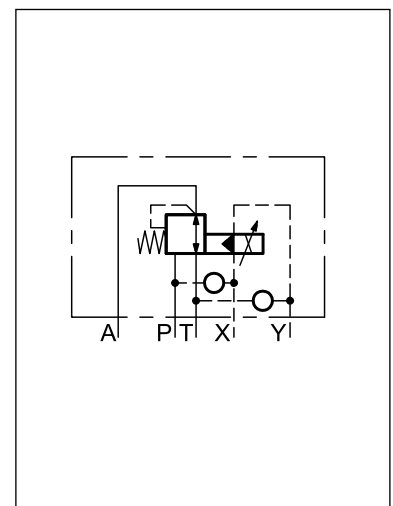



1 - IDENTIFICATION CODE

	D	Z	C	E		-	/	30		-		/	K9			
--	----------	----------	----------	----------	--	---	---	-----------	--	---	--	---	-----------	--	--	--

Pressure reducing valve

Electric proportional control

Nominal size: _____
5 = CETOP P05
5R = ISO 4401-05
7 = ISO 4401-07
8 = ISO 4401-08

Explosion-proof certification: _____
See table 1.1

Pressure adjustment range: _____
070 = 1 ÷ 70 bar
140 = 1 ÷ 140 bar
210 = 1.2 ÷ 210 bar
320 = 1.8 ÷ 320 bar

Series No. (the overall and mounting dimensions remain unchanged from 30 to 39)

Seals: _____
 For temperature range -20 / +80 °C
N = NBR seals for mineral oil (**standard**)
V = FPM seals for special fluids
 For temperature range -40 / +80 °C
NL = seal for low temperatures (for mineral oil)

Option: surface treatment not standard.
 Omit if not required (see **NOTE**)

Option: **/T5** version in T5 temperature class.
 Omit if not required.

Connection type for cable gland upper connection:
T01 = M20x1.5 - ISO 261
T02 = Gk 1/2 - UNI EN 10226-2
T03 = 1/2" NPT - ANSI B1.20.1 (ex ANSI B2.1)
 side connection:
S01 = M20x1.5 - ISO 261
S02 = Gk 1/2 - UNI EN 10226-2
S03 = 1/2" NPT - ANSI B1.20.1 (ex ANSI B2.1)
S04 = M16x1.5 - ISO 261

Coil electrical connection: junction box

Nominal solenoid voltage:
D12 = 12 V DC
D24 = 24 V DC

Drainage: **I** = internal
E = external

Piloting: **I** = internal
E = external

NOTE: Valves are supplied with standard surface treatment of phosphating black. Zinc-nickel surface treatment is available upon request. It is suitable to ensure a salt spray resistance up to 600 h (test operated according to UNI EN ISO 9227 standards and test evaluation operated according to UNI EN ISO 10289 standards). For zinc-nickel surface treatment add the suffix **/W7** at the end of the identification code.

Version with monobloc steel coil
 Standard coils are made of zinc-nickel steel, with anodized aluminium junction box on it. Monobloc coils **MD24K9S01** completely made of steel are available upon request. They have zinc-nickel treatment, power supply voltage D24 and cable gland connection type S01. Other variants for voltage and cable gland connection are available, always on request.

1.1 - Names of valves per certification

	ATEX		IECEX		PESO	
for gases for dusts	KD2	II 2GD	KXD2	IECEX Gb IECEX Db	KPD2	PESO Gb not applicable for dust
for mines	KDM2	I M2	KXDM2	IECEX Mb	not applicable for mines	

NOTE: Refer to the technical data sheet 02 500 for marking, operating temperatures and available versions.

2 - DETAILED SYMBOL

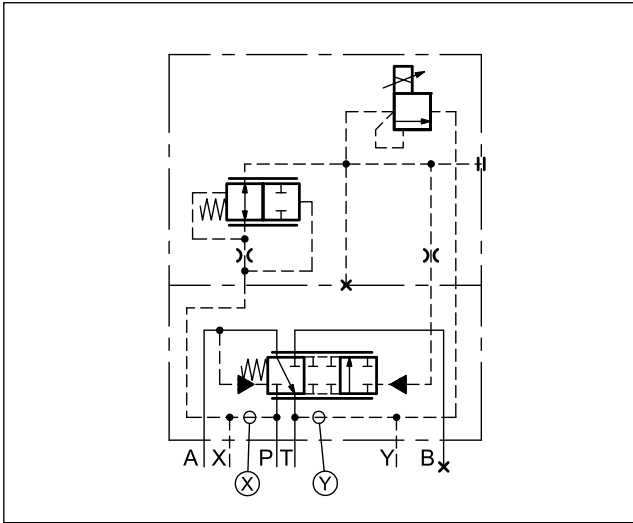

3 - MAX PRESSURE VALUES

This valve incorporates a mechanical limit of the maximum pressure, that operates independently of the applied current. This kind of design ensures that the pressure cannot rise over even if the solenoid current exceeds the maximum current ($I > I_{max}$).

Values obtained with oil viscosity of 36 cSt at 50°C

		DZCE*K*-070	DZCE*K*-140	DZCE*K*-210	DZCE*K*-320
pressure value at 800 mA	bar	78	140	210	320
max pressure value when $I > I_{max}$	bar	90	150	250	330

4 - CHARACTERISTIC CURVES

(obtained with mineral oil with viscosity of 36 cSt at 50°C)

The characteristic curves are measured without hysteresis, linearity compensation and without any backpressure in T.

4.1 - Characteristic curves DZCE5K* and DZCE5RK*

CONTROLLED PRESSURE

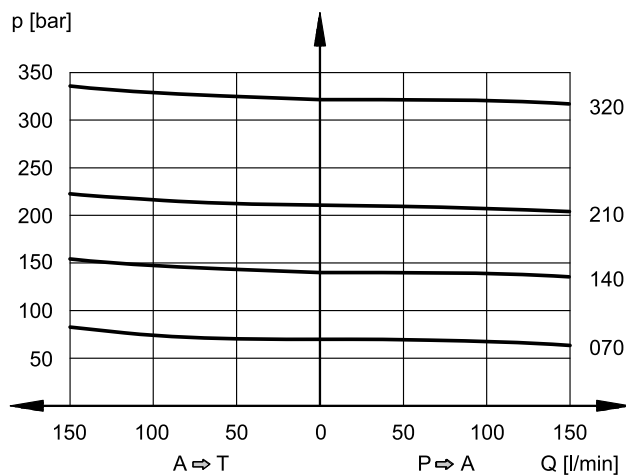

MIN. CONTROLLED PRESSURE $p_{min} = f(Q)$

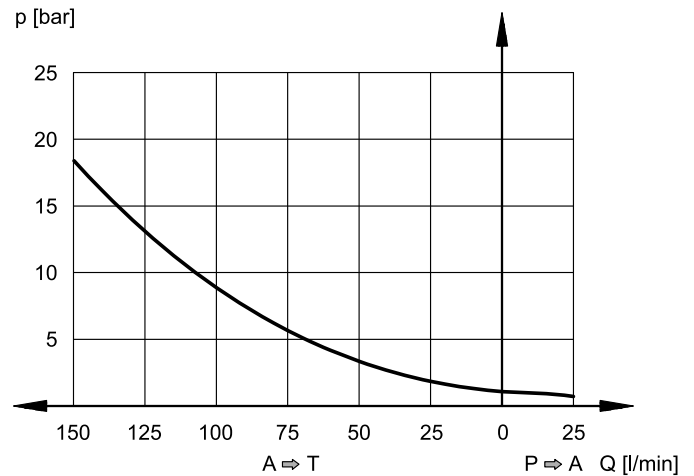

Pressure drops A → T as a function of the flow rate, without any backpressure in T and with command signal = 0V



PRESSURE CONTROL $p = f(I)$

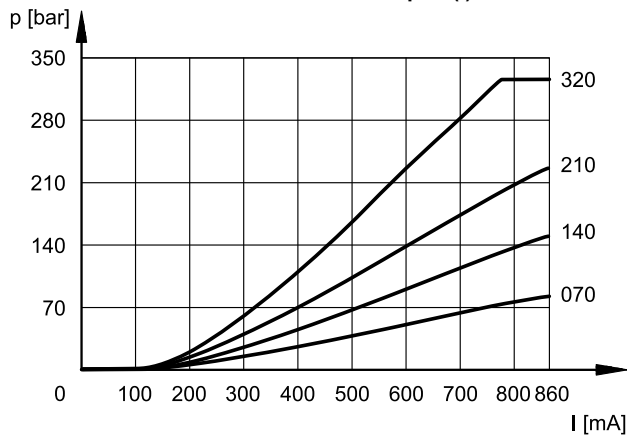

Characteristic curves as a function of the current to the solenoid for the available pressure adjustment ranges, obtained with A port plugged.

4.2 - Characteristic curves DZCE7K*

CONTROLLED PRESSURE

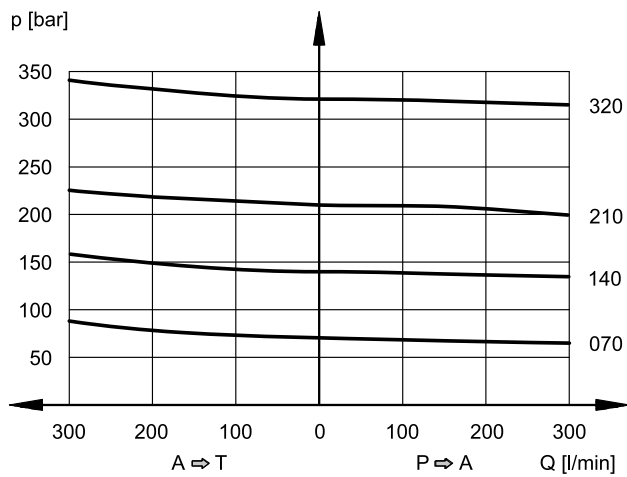

MIN. CONTROLLED PRESSURE $p_{min} = f(Q)$

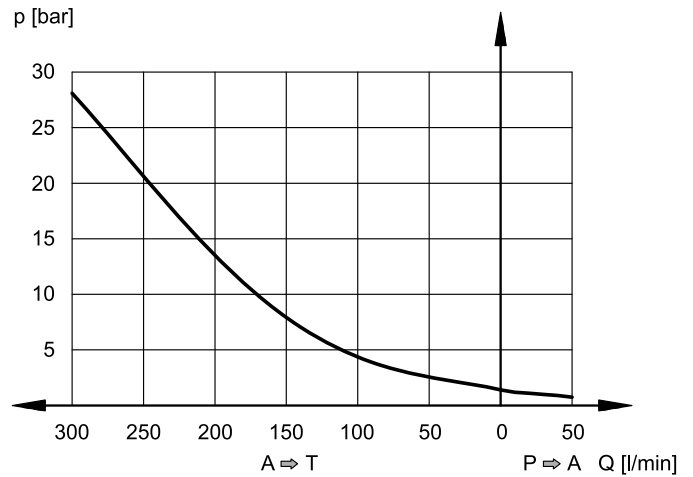

PRESSURE CONTROL $p = f(I)$

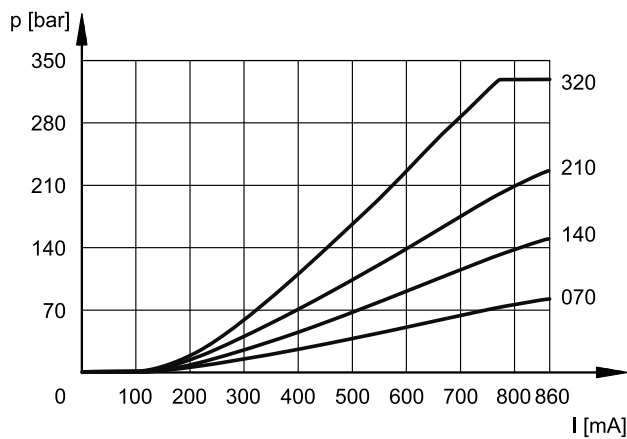

4.3 - Characteristic curves DZCE8K*

CONTROLLED PRESSURE

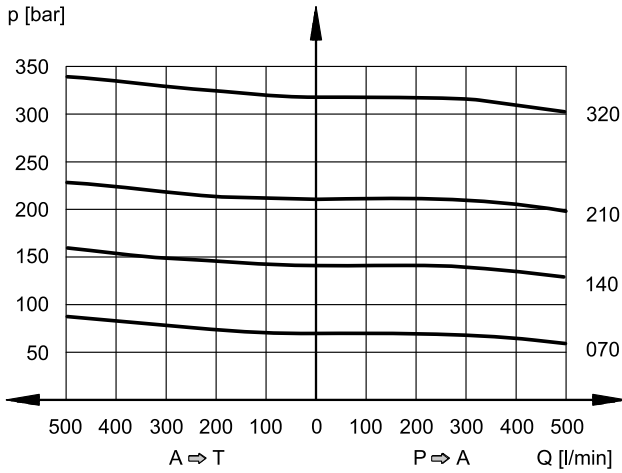

MIN. CONTROLLED PRESSURE $p_{min} = f(Q)$

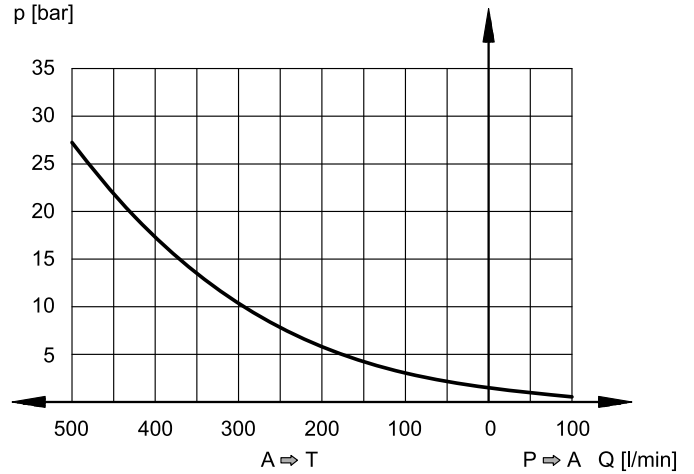

PRESSURE CONTROL $p = f(I)$

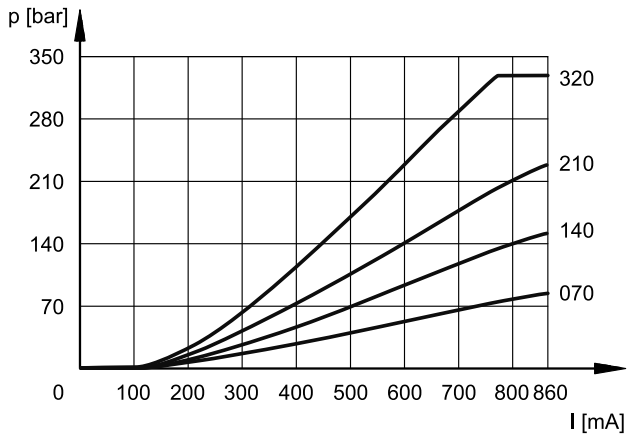

5 - STEP RESPONSE

(measured with mineral oil with viscosity of 36 cSt at 50°C)

Step response is the time taken for the valve to reach 90% of the set pressure value following a step change of reference signal.

The values change significantly according to the variation of the available flow rate and to the construction of the circuit.

REFERENCE SIGNAL	0 → 100%	100 → 0%
Response times [ms]		
DZCE5K* and DZCE5RK*	100	50
DZCE7K*	100	50
DZCE8K*	150	70

6 - ELECTRICAL CHARACTERISTICS

(values ± 5%)

NOMINAL VOLTAGE	V DC	12	24
RESISTANCE (AT 20°C)	Ω	3.8	15.6
NOMINAL CURRENT	A	1.88	0.86

DUTY CYCLE	100%
ELECTROMAGNETIC COMPATIBILITY (EMC)	According to 2014/30/EU
CLASS OF PROTECTION: Atmospheric agents Coil insulation (VDE 0580)	IP66/IP68 class H

6.1 - Wiring

In order to realise the electrical connection of the coil, it is necessary to access the terminal block (1) unscrewing the 4 screws (2) that fasten the cover (3) with the box (4) that contains the terminal block.

The electrical connection is polarity-independent.

By doing electrical connection it is important to connect also the grounding point (5) in the terminal block box (M4 screws), through suitable conductors with the general grounding line of the system.

On the external body of the coil, there is a grounding point (6) (M4 screw) that makes it possible to ensure equipotentiality between the valve and the general grounding line of the system; connecting this point, the regulation of the EN 13463-1 standard that requires verifying the equipotentiality of the elements included in a potentially explosive environment (the maximum resistance between the elements must be 100 Ω) is guaranteed.

At the end of the electrical wiring, it is necessary to reassemble the cover (3) on the box (4), checking the correct positioning of the seal located in the cover seat and fastening the 4 M5 screws with a torque of 4.9+6 Nm.

Electrical wiring must be done in compliance with standards about protection against explosion hazards.

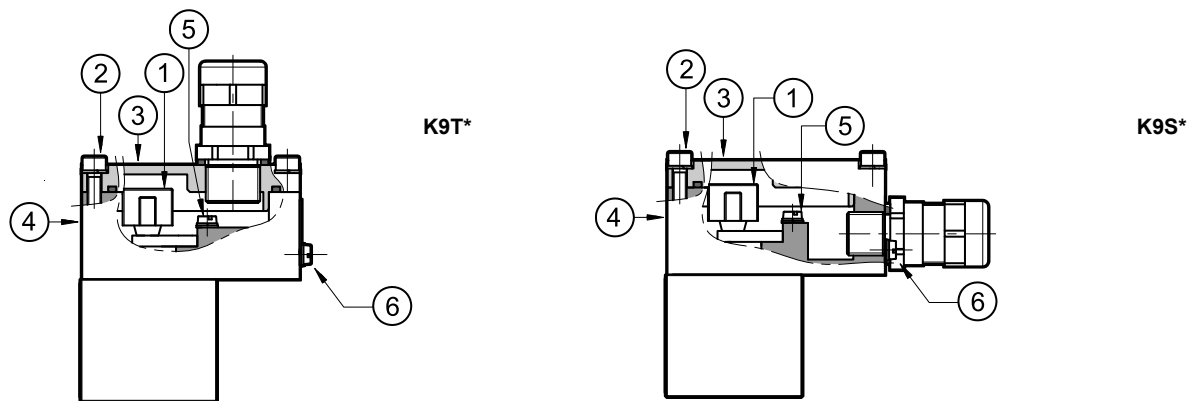

Characteristics of the cables connectable for wiring are indicated in the table below:

Function	Cable section
Operating voltage cables connection	max 2.5 mm ²
Connection for internal grounding point	max 2.5 mm ²
Connection for external equipotential grounding point	max 6 mm ²

Cables for wiring must be non-armoured cables, with external covering sheath and must be suitable for use in environments with temperatures from - 20 °C to +110 °C (for valves either with N or V seals) or from - 40 °C to +110 °C (for valves with NL seals).

Cable glands (which must be ordered separately, see point 15) allow to use cables with external diameter between 8 and 10 mm.

6.2 - Electrical diagram

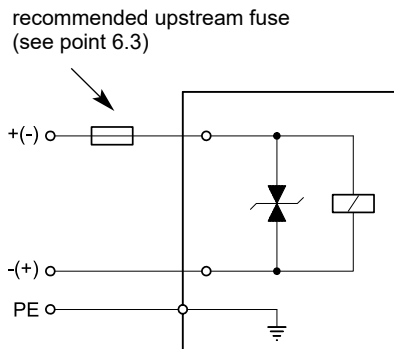

6.3 - Overcurrent fuse and switch-off voltage peak

Upstream of each valve, an appropriate fuse (max 3 x I_n according to IEC 60127) or a protective motor switch with short-circuit and thermal instantaneous tripping, as short-circuit protection, must be connected. The cut-off power of the fuse must correspond or exceed the short circuit current of the supply source. The breaking capacity of the fuse link shall be the same as or higher than the maximum short-circuit current expected to occur at the place of installation (normally 1500 A).

The fuse or the protective motor must be placed outside the dangerous area or they must be protected with an explosion-proof covering.

In order to safeguard the electronic device to which the valve is connected, there is a protection circuit in the coil that reduces voltage peaks, which can occur when inductances are switched off.

The table shows the type of fuse recommended according to the nominal voltage of the valve and to the value of the voltage peaks reduction.

Coil type	Nominal voltage [V]	Rated current [A]	Recommended pre-fuse characteristics medium time-lag according to DIN 41571 [A]	Maximum voltage value upon switch off [V]	Suppressor circuit
D12	12	1.88	2.5	- 49	Transient voltage suppressor bidirectional
D24	24	0.86	1.25	- 49	

7 - PILOTING AND DRAINAGE

The DZCE*K* valves are available with pilot and drain both internal and external. The version with external drain allows a higher back pressure on the discharge line.

NOTE: The configuration of pilots and drains must be chosen when ordering. Subsequent modifications are allowed only to specialized operators with authorization and in factory.

TYPE OF VALVE	Plug assembly	
	X	Y
IE internal pilot and external drain	NO	YES
II internal pilot and internal drain	NO	NO
EE external pilot and external drain	YES	YES
EI external pilot and internal drain	YES	NO

DZCE5K* and DZC5RK*

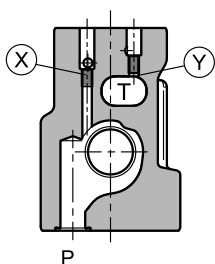

DZCE7K*

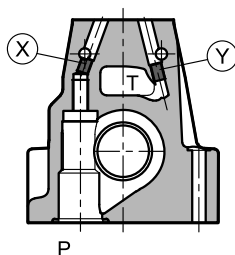

DZCE8K*

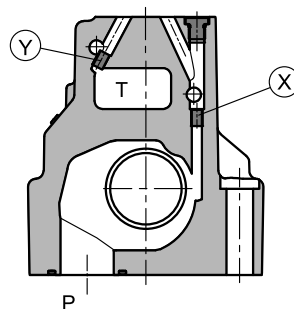

X: M5x6 plug for external pilot
Y: M5x6 plug for external drain

X: M6x8 plug for external pilot
Y: M6x8 plug for external drain

PRESSURES (bar)

Pressure	MAX
Piloting pressure on external X port	350 (NOTE)
Pressure on T port with internal drain	2
Pressure on T port with external drain	250

NOTE: Anyway, the pilot pressure must be 10% higher than the set value for the reduced pressure, in order to let the valve work properly.

8 - DZCE5K* AND DZCE5RK* WITH UPPER CONNECTION - OVERALL AND MOUNTING DIMENSIONS

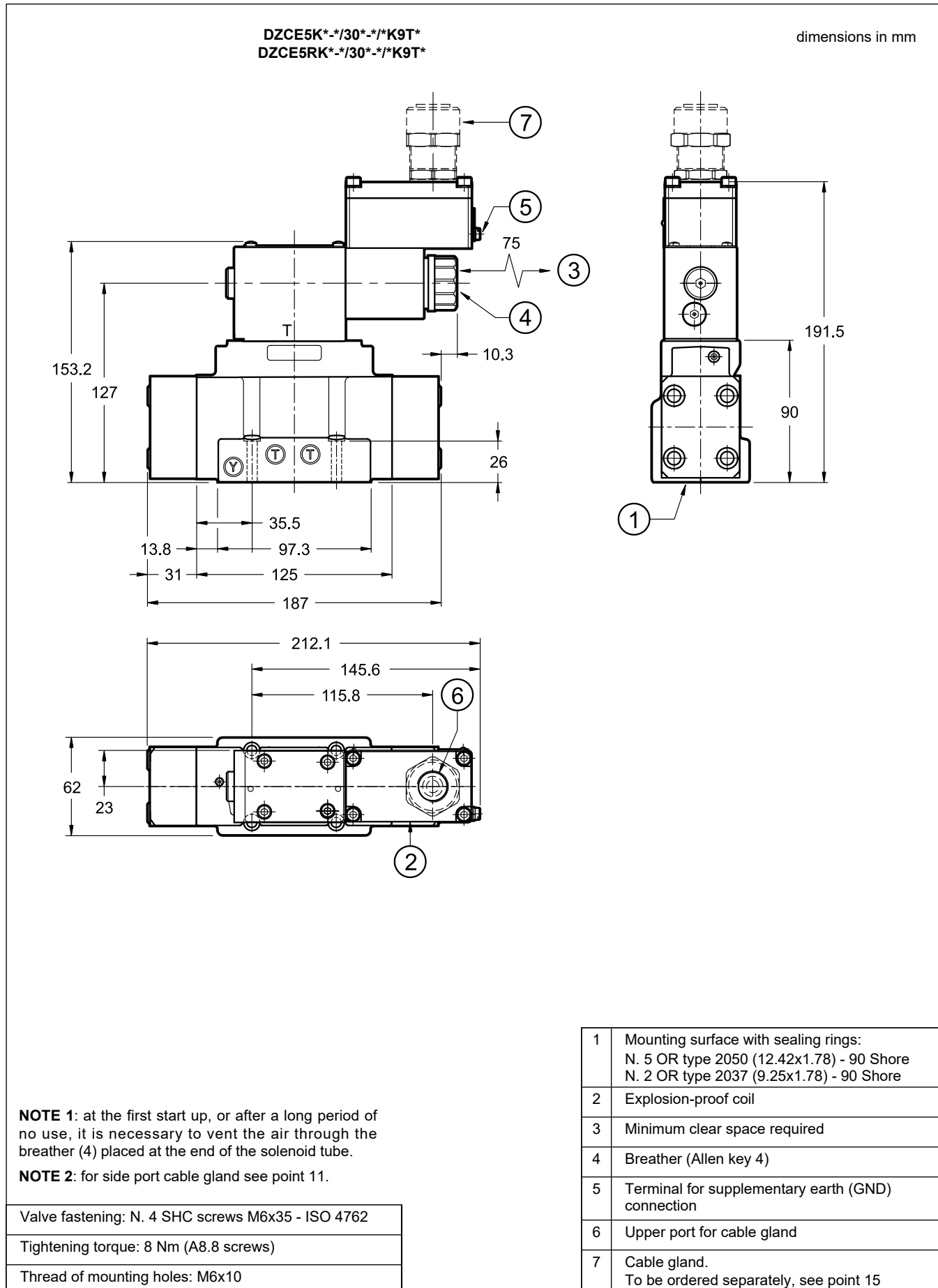

9 - DZCE7K* WITH UPPER CONNECTION - OVERALL AND MOUNTING DIMENSIONS

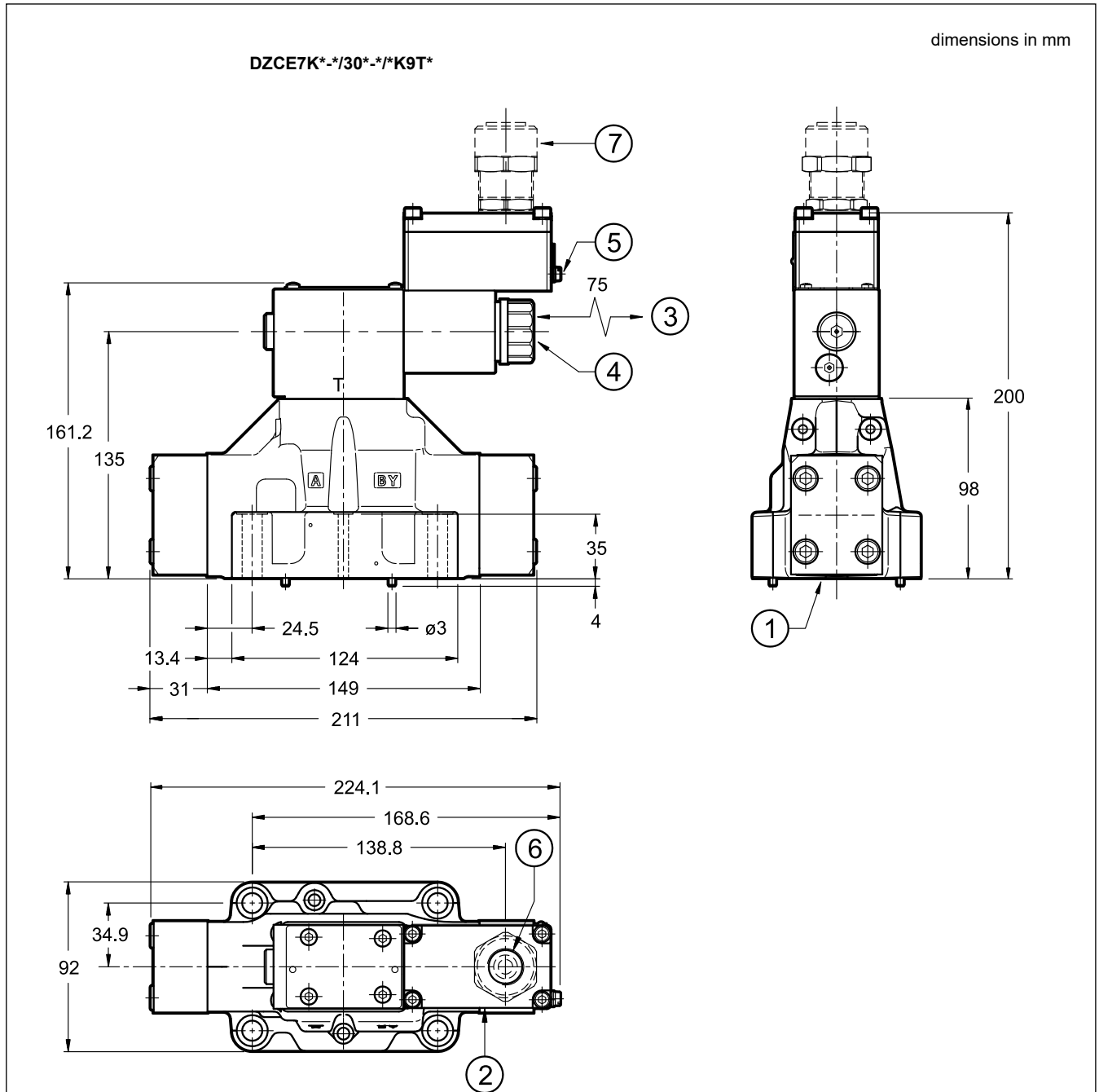

NOTE 1: at the first start up, or after a long period of no use, it is necessary to vent the air through the breather (4) placed at the end of the solenoid tube.

NOTE 2: for side port cable gland see point 11.

Single valve fastening:	N. 4 SHC screws M10x50 - ISO 4762 N. 2 SHC screws M6x50 - ISO 4762
Tightening torque	M10x50: 40 Nm (A8.8 screws) M6x50: 8 Nm (A8.8 screws)
Thread of mounting holes:	M6x18; M10x18

1	Mounting surface with sealing rings: 4 OR type 130 (22.22x2.62) - 90 Shore 2 OR type 2043 (10.82x1.78) - 90 Shore
2	Explosion-proof coil
3	Minimum clear space required
4	Breather (Allen key 4)
5	Terminal for supplementary earth (GND) connection
6	Upper port for cable gland
7	Cable gland. To be ordered separately, see point 15

10 - DZCE8K* WITH UPPER CONNECTION - OVERALL AND MOUNTING DIMENSIONS

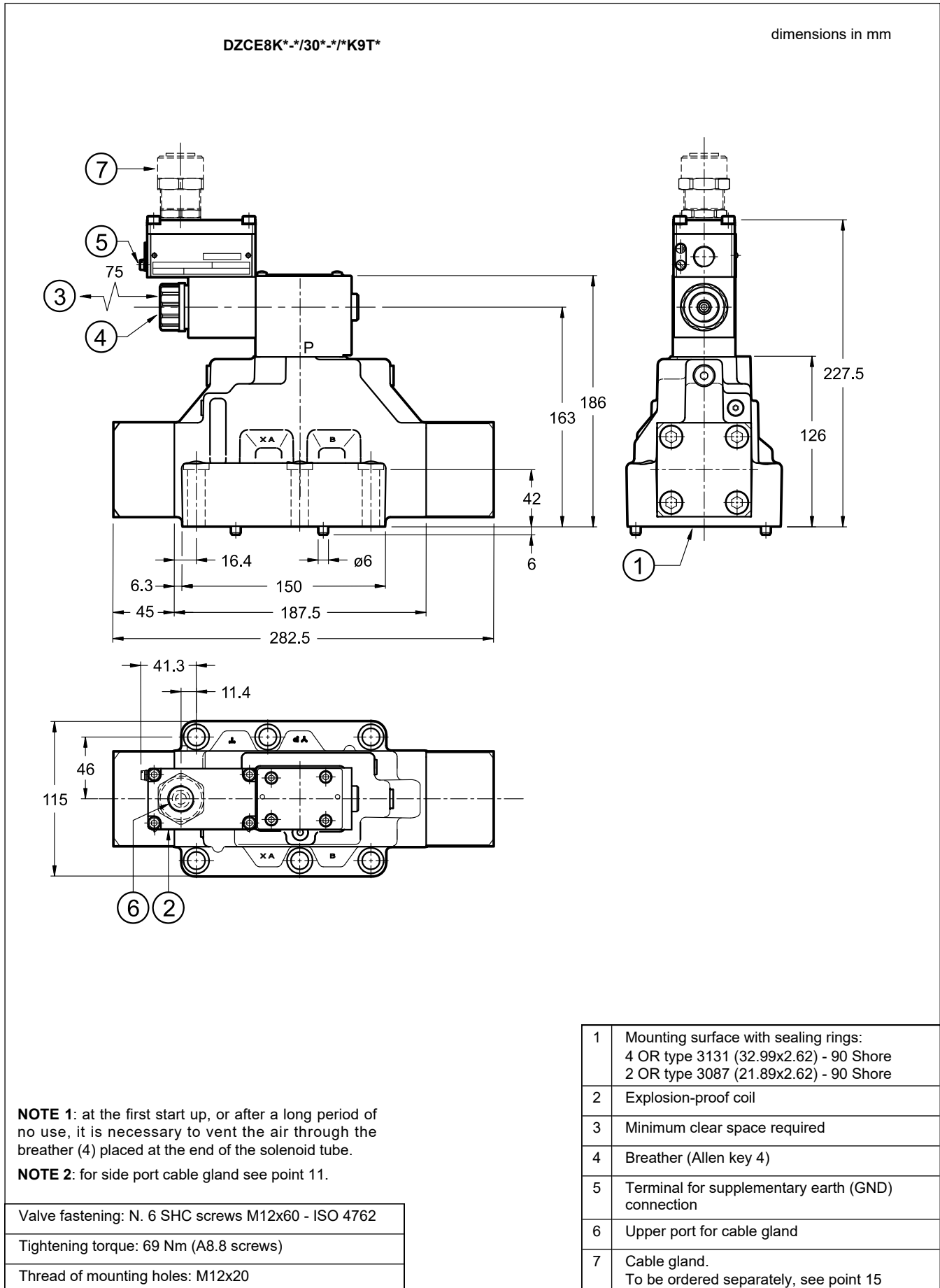

11 - DZCE*K* WITH SIDE CONNECTION - OVERALL AND MOUNTING DIMENSIONS

dimensions in mm

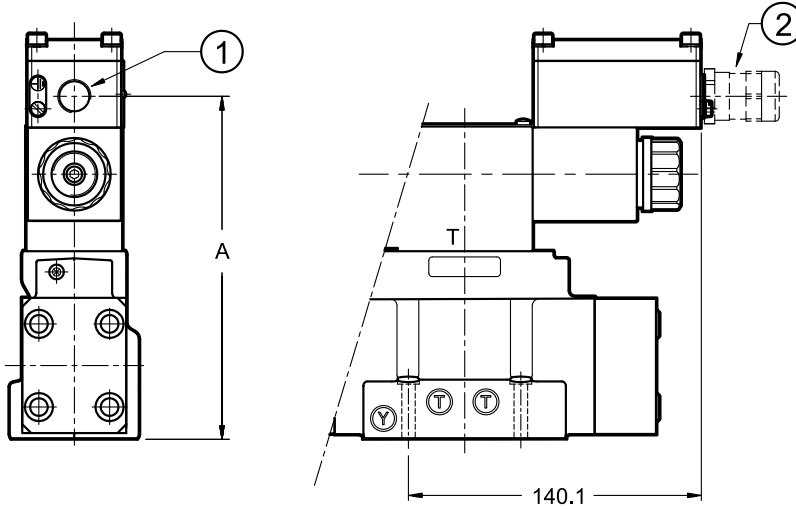

DZCE5K*/30*/K9S*
DZCE5RK*/30*/K9S*

Side port type	Dimension A
S01, S04	164.5
S02, S03	164

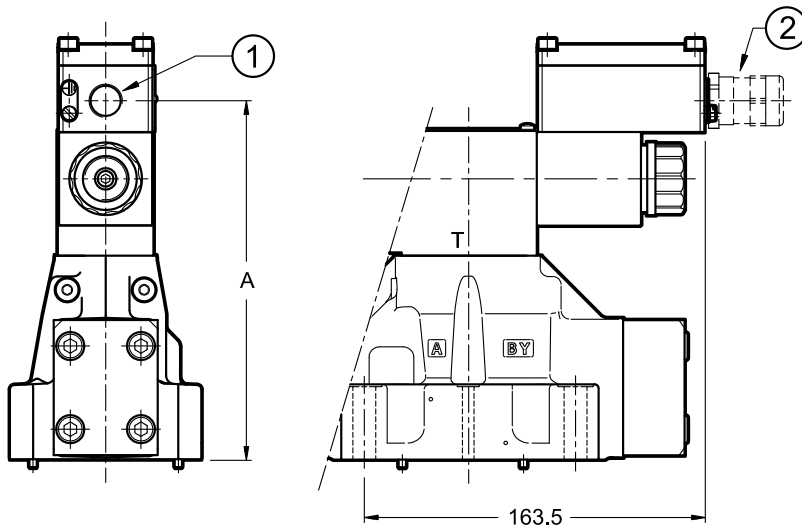

DZCE7K*/30*/K9S*

Side port type	Dimension A
S01, S04	172.5
S02, S03	170

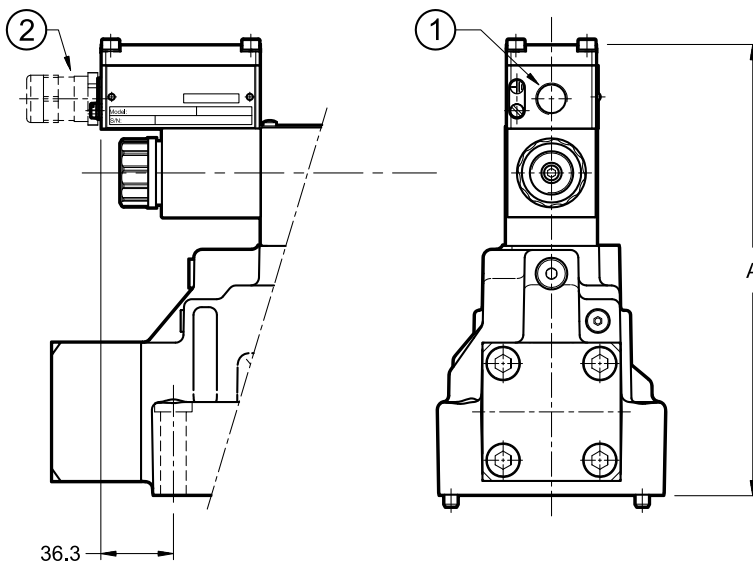

DZCE8K*/30*/K9S*

Side port type	Dimension A
S01, S04	227.5
S02, S03	227

1	Side port for cable gland
2	Cable gland. To be ordered separately, see p. 15



12 - MOUNTING SURFACES

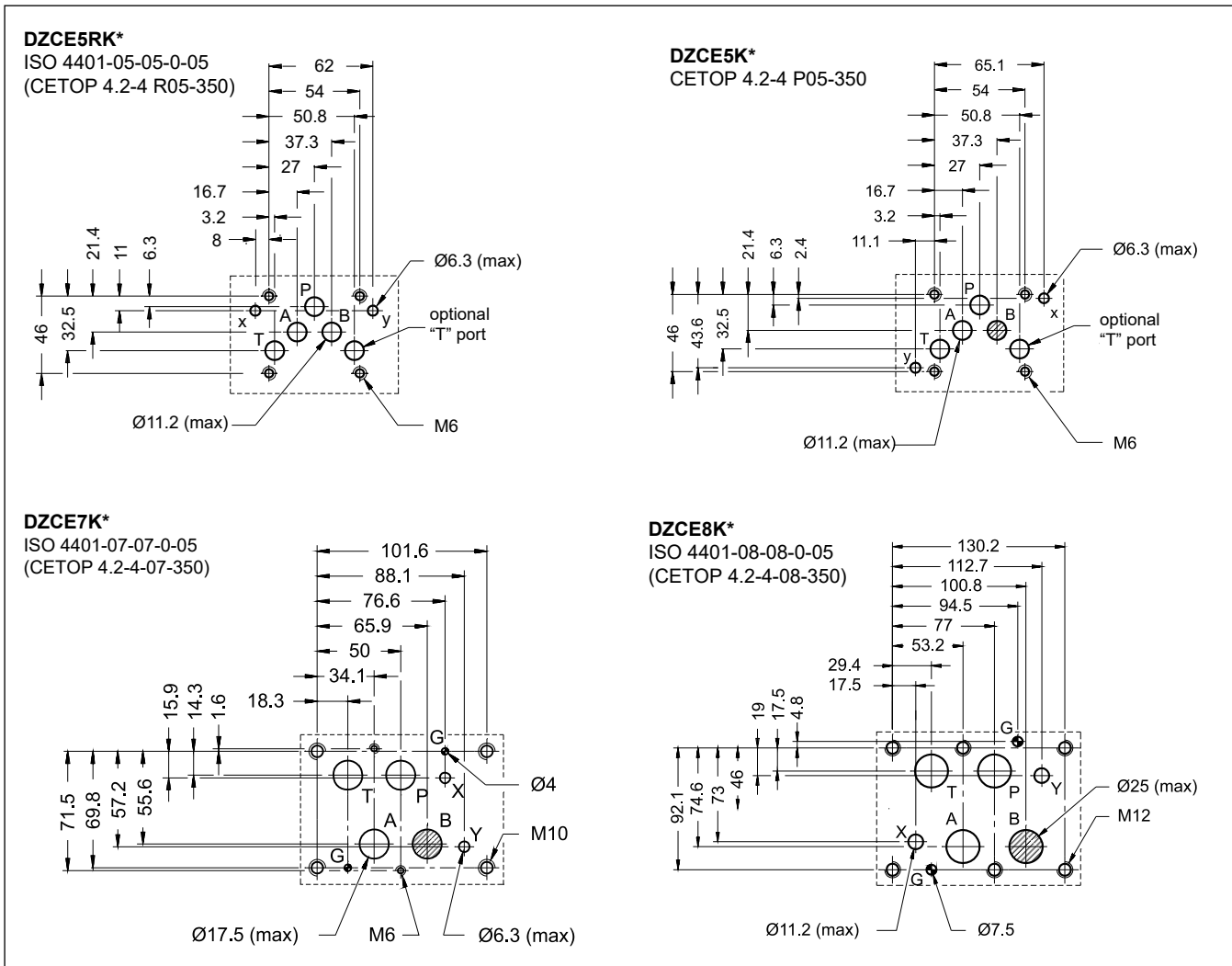

13 - HYDRAULIC FLUIDS

Use mineral oil-based hydraulic fluids HL or HM type, according to ISO 6743-4. For these fluids, use NBR seals (code N). For fluids HFDR type (phosphate esters) use FPM seals (code V). For the use of other kinds of fluid such as HFA, HFB, HFC, please consult our technical department. Using fluids at temperatures higher than 80 °C causes a faster degradation of the fluid and of the seals characteristics.

The fluid must be preserved in its physical and chemical characteristics.

14 - INSTALLATION



Installation must adhere to instructions reported in the Use and Maintenance manual, always attached to the valve. Unauthorized interventions can be harmful to people and goods because of the explosion hazards present in potentially explosive atmospheres.

The DZCE*K* valves can be installed in any position without impairing correct operation.

Ensure that there is no air in the hydraulic circuit. In particular applications, it can be necessary to vent the air entrapped in the solenoid tube, by using the appropriate drain screw in the solenoid tube. So, ensure the solenoid tube is always filled with oil. When finished, make sure you have screwed the screw back in correctly.

Connect the valve T port directly to the tank. Add any backpressure value detected in the T line to the controlled pressure value.

Maximum admissible backpressure in the T line, under operational conditions, is 2 bar.

Valves are fixed by means of screws or tie rods on a flat surface with planarity and roughness equal to or better than those indicated in the relative symbols. If minimum values are not observed, fluid can easily leak between the valve and support surface.

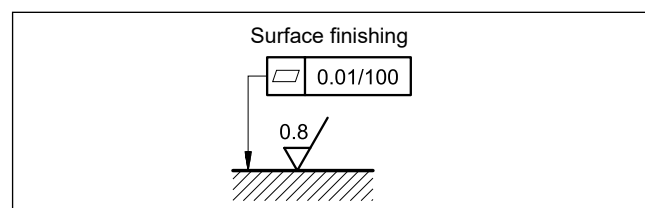

15 - CABLE GLANDS

Cable glands must be ordered separately; Duplomatic offers some types of cable glands with the following features:

- version for non-armoured cable, external seal on the cable (suitable for $\varnothing 8+10$ mm cables);
- ATEX II 2GD, I M2; IECEx Gb, Db, Mb;
- cable gland material: nickel brass
- inner rubber tip material: silicone
- ambient temperature range: $-65\text{ }^{\circ}\text{C} \div +220\text{ }^{\circ}\text{C}$
- protection degree: IP66/IP68

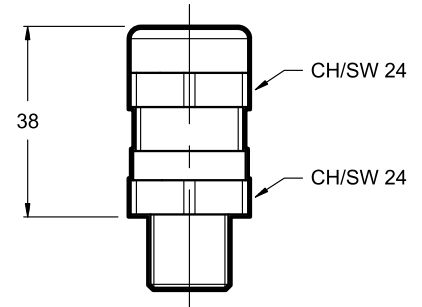

To order the desired cable glands, specify description, code and quantity.

Description: CGK2/NB-01/10

Code: 3908108001

M20x1.5 - ISO 261 male thread, suitable for coils with T01 and S01 connections. It is supplied equipped with copper washer, that must be assembled between the cable gland and the coil, so as to ensure IP66/IP68 protection degree.

Tightening torque: $45 \div 50$ Nm

Description: CGK2/NB-02/10

Code: 3908108002

Gk 1/2 - UNI EN 10226-2 male thread, suitable for coils with T02 and S02 connections. The customer must apply LOCTITE® 243™ threadlocker or similar between the cable gland connection thread and the coil in order to ensure IP66/IP68 protection degree.

Tightening torque: $20 \div 25$ Nm

Description: CGK2/NB-03/10

Code: 3908108003

1/2" NPT - ANSI B1.20.1 (ex ANSI B2.1), suitable for coils with T03 and S03 connections. The customer must apply LOCTITE® 243™ threadlocker or similar between the cable gland connection thread and the coil in order to ensure IP66/IP68 protection degree.

Tightening torque: $20 \div 25$ Nm

Description: CGK2/NB-04/10

Code: 3908108004

M16x1.5 - ISO 261 male thread, suitable for coils with S04 connection. It is supplied equipped with copper washer, that must be assembled between the cable gland and the coil, so as to ensure IP66/IP68 protection degree.

Tightening torque: $45 \div 50$ Nm

16 - ELECTRONIC CONTROL UNITS

EDM-M112	for solenoid 24V DC	DIN EN 50022 rail mounting	see cat. 89 252
EDM-M142	for solenoid 12V DC		

NOTE: electronic control units offered are not explosion-proof certified; therefore, they must be installed outside classified areas.

17 - SUBPLATES

(see catalogue 51 000)

	DZCE5K*	DZCE7K*	DZCE8K*
Type with rear ports	PME4-AI5G	PME07-AI6G	-
Type with side ports	PME4-AL5G	PME07-AL6G	PME5-AL8G
Thread of ports:	P - T - A - B X - Y	3/4" BSPP 1/4" BSPP	1 1/2" BSPP 1/4" BSPP

NOTE: Subplates (to be ordered separately) contain neither aluminium nor magnesium at a rate higher than the value allowed by norms according to ATEX directive for category II 2GD and I M2.

The user will bear to do the complete assessment of the ignition risk that can occur from the relative use in potentially explosive environments.



DZCE*K*
SERIES 30

DUPLOMATIC
MOTION SOLUTIONS
*a member of **DAIKIN** group*

DUPLOMATIC MS Spa

via Mario Re Depaolini, 24 | 20015 Parabiago (MI) | Italy

T +39 0331 895111 | E vendite.ita@duplomatic.com | sales.exp@duplomatic.com

duplomaticmotionsolutions.com

EXPLOSION-PROOF CLASSIFICATION

for

SOLENOID AND PROPORTIONAL VALVES

ref. catalogues:

pressure control valves

RQM*K*-P	21 515
P*E*K*	81 316
ZDE3K*	81 515
DZCE*K*	81 606

flow control valves

QDE3K*	82 225
---------------	---------------

directional valves

D*K*	41 515
DT3K*	42 215
DS(P)E*K*	83 510

GENERAL INFO

This informative technical datasheet displays information about **classification and marking** of Duplomatic explosion-proof valves range.

Duplomatic MS offers valves with the following certifications:

ATEX	II 2G	II 2D	I M2
IECEX	Gb	Db	Mb
PESO	Gb		

Instructions for use and maintenance can be found in the related manuals, always supplied together with valves.



1 - ATEX CLASSIFICATION AND TEMPERATURES

Diplomatic certificates the combination valve-coil for the valves suitable for application and installation in potentially explosive atmospheres, according to ATEX directive; the supply always includes the declaration of conformity to the directive and the operating and maintenance manual, that contains all the information needed for a correct use of the valve in potentially explosive environments.

Coils assembled on these valves have been separately certified according to ATEX directive and so they are suitable for use in potentially explosive atmospheres.

1.1 - ATEX classification for valves

Type examination certificate: AR18ATEX055

The valves are suitable for applications and installations in potentially explosive atmospheres that fall within:

ATEX II 2G ATEX II 2D	*KD2	equipment intended for use in areas in which explosive atmospheres caused by gases, vapours, mists or air/dust mixtures are likely to occur occasionally. The means of protection relating to equipment in this category ensure the requisite level of protection, even in the event of frequently occurring disturbances or equipment faults which normally have to be taken into account.
ATEX I M2	*KDM2	equipment intended for use in underground parts of mines as well as those parts of surface installations of such mines likely to be endangered by firedamp and/or combustible dust. This equipment is intended to be de-energised in the event of an explosive atmosphere.

1.2 - ATEX marking for valves

valve code		N and V seals	NL seals
*KD2	for gas	⊕ II 2G IIC T4 Gb (-20°C Ta +80°C)	⊕ II 2G IIC T4 Gb (-40°C Ta +80°C)
	for dusts	⊕ II 2D IIIC T154°C Db IP66/IP68 (-20°C Ta +80°C)	⊕ II 2D IIIC T154°C Db IP66/IP68 (-40°C Ta +80°C)
*KD2 /T5	for gas	⊕ II 2G IIC T5 Gb (-20°C Ta +55°C)	⊕ II 2G IIC T5 Gb (-40°C Ta +55°C)
	for dusts	⊕ II 2D IIIC T129°C Db IP66/IP68 (-20°C Ta +55°C)	⊕ II 2D IIIC T129°C Db IP66/IP68 (-40°C Ta +55°C)
*KDM2	mining	⊕ I M2 I T150°C Mb IP66/68 (-20°C Ta +75°C)	⊕ I M2 I T150°C Mb IP66/68 (-40°C Ta +75°C)

Specific marking as ATEX 2014/34/EU directive and related technical specifications

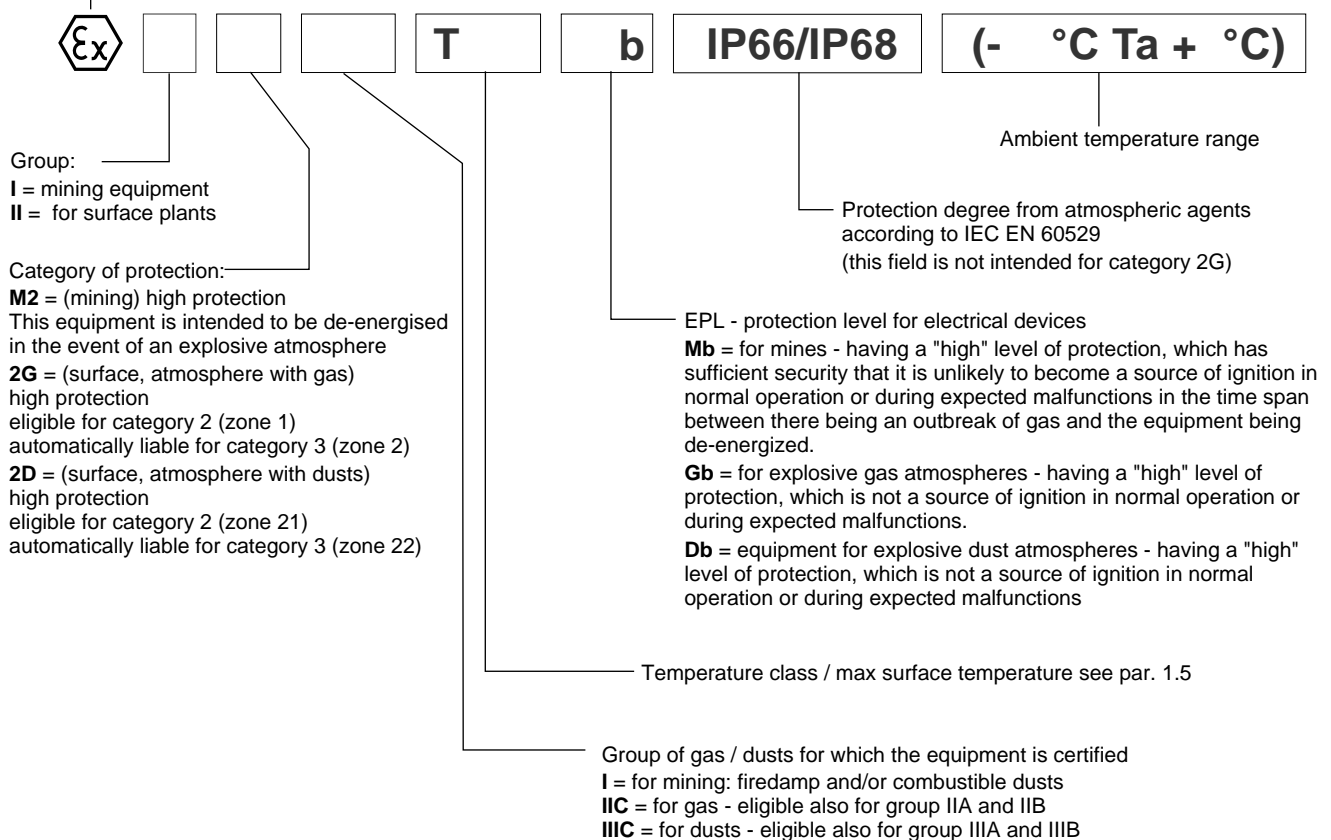



1.3 - ATEX classification of the coils

The coil of the explosion-proof valves is ATEX certified itself and, as such, is identified with its own tag, carries the relative ATEX marking. The mechanical construction of the coil housing is made in order to ensure its resistance to possible internal explosion and to avoid any explosion propagation to the outside environment, matching an "Ex db" type protection (explosion-proof coil).

Moreover, the solenoid is designed to maintain its surface temperature below the limits specified to the relevant class.

1.4 - ATEX marking on coils

for valve type *KD2	for gas for dusts	II 2G Ex db IIC T4 Gb (-40°C Ta +80°C) II 2D Ex tb IIIC T154°C Db IP66/IP68 (-40°C Ta +80°C)
for valve type *KD2 /T5	for gas for dusts	II 2G Ex db IIC T5 Gb (-40°C Ta +55°C) II 2D Ex tb IIIC T129°C Db IP66/IP68 (-40°C Ta +55°C)
for valve type *KDM2	mining	I M2 Ex db I T150°C Mb IP66/IP68 (-40°C Ta +75°C)

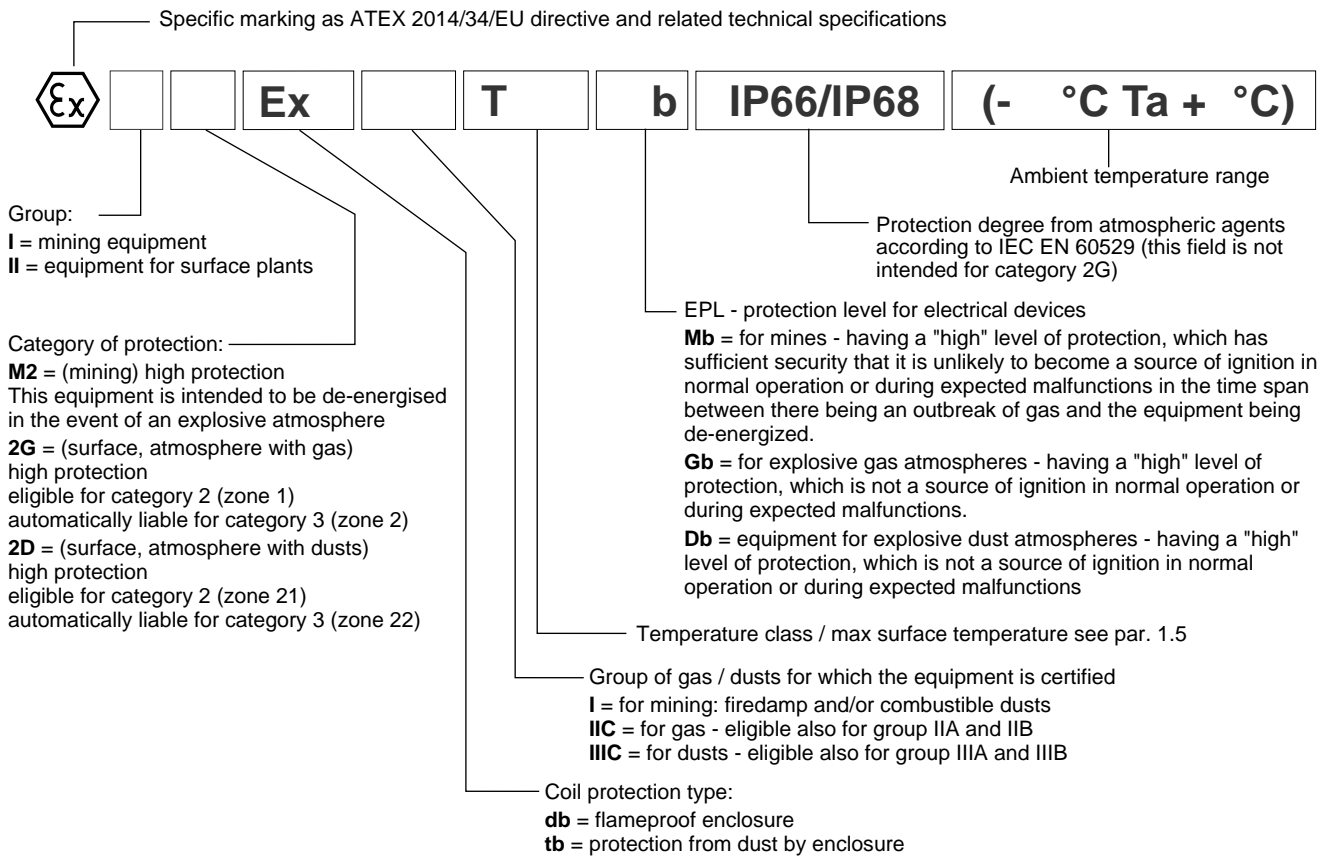

1.5 - Operating temperatures

These valves are classified according to their maximum surface temperature (EN 13463-1), which must be lower than the ignition temperature of the gases, vapors and dusts for which the area in which they will be used is classified.

The valves in group II can also be used for less limiting temperature classes (surface temperature allowed higher).

		temperature range	N and V seals	NL seals	Temperature class	eligible also for
ATEX II 2G ATEX II 2D	*KD2	of ambient	-20 / +80 °C	-40 / +80 °C	T4 (gas)	T3, T2, T1
		of fluid			T154°C (dusts)	T200°C and higher
	*KD2 /T5	of ambient	-20 / +55 °C	-40 / +55 °C	T5 (gas)	T4, T3, T2, T1
		of fluid			T129°C (dusts)	T135°C and higher
ATEX I M2	*KDM2	of ambient	-20 / +75 °C	-40 / +75 °C	T150°C	-
		of fluid				



2 - IECEX CLASSIFICATION AND TEMPERATURES

The IECEX certification requires the classification of the electrical equipment only.

Diplomatic supplies valves with IECEX certified coils, suitable for application and installation in potentially explosive atmospheres. The mechanical construction of the coil housing is made in order to ensure its resistance to possible internal explosion and to avoid any explosion propagation to the outside environment, matching an "Ex db" type protection (explosion-proof coil).

Moreover, the solenoid is designed to maintain its surface temperature below the limits specified to the relevant class.

The supply always includes the operating and maintenance manual, that contains all the information needed for a correct use of the valve in potentially explosive environment.

2.1 - IECEX classification

Certificate of conformity (CoC): IECEX TUN 15.0028X

The valves are suitable for applications and installations in potentially explosive atmospheres that fall within:

IECEX Gb IECEX Db	*KXD2	equipment intended for use in areas in which explosive atmospheres caused by gases, vapours, mists or air/dust mixtures are likely to occur occasionally. The means of protection relating to equipment in this category ensure the requisite level of protection, even in the event of frequently occurring disturbances or equipment faults which normally have to be taken into account.
IECEX Mb	*KXDM2	equipment intended for use in underground parts of mines as well as those parts of surface installations of such mines likely to be endangered by firedamp and/or combustible dust. This equipment is intended to be de-energised in the event of an explosive atmosphere.

2.2 - IECEX marking

There is a plate with the IECEX mark on each coil.

*KXD2 valves	for gas	Ex db IIC T4 Gb (-40°C Ta +80°C)
	for dusts	Ex tb IIIC T135°C Db (-40°C Ta +80°C)
*KXD2 /T5 valves	for gas	Ex db IIC T5 Gb (-40°C Ta +55°C)
	for dusts	Ex tb IIIC T100°C Db (-40°C Ta +55°C)
*KDM2 valves	mining	Ex db I Mb (-40°C Ta +80°C)

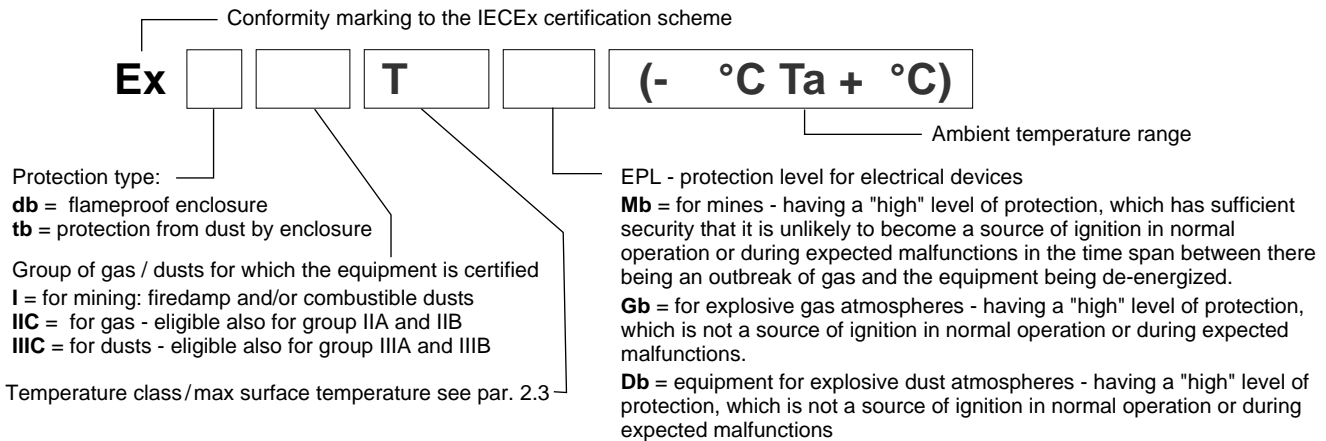

2.3 - Operating temperatures

These valves are classified according to their maximum surface temperature (EN 13463-1), which must be lower than the ignition temperature of the gases, vapors and dusts for which the area in which they will be used is classified.

Valves for surface plants can also be used for less limiting temperature classes (higher surface temperature allowed).

		temperature range	N and V seals	NL seals	Temperature class	eligible also for
IECEX Gb IECEX Db	*KXD2	of ambient	-20 / +80 °C	-40 / +80 °C	T4 (gas) T135°C (dusts)	T3, T2, T1 T200°C and higher
		of fluid				
IECEX Db	*KXD2 /T5	of ambient	-20 / +55 °C	-40 / +55 °C	T5 (gas) T100°C (dusts)	T4, T3, T2, T1 T135°C and higher
		of fluid				
IECEX Mb	*KXDM2	of ambient	-20 / +80 °C	-40 / +80 °C	-	-
		of fluid				

2.4 - Protection degree from atmospheric agents (IEC EN 60529)

Protection degree from atmospheric agents according to IEC EN 60529 is IP66/IP68.



3 - PESO CLASSIFICATION AND TEMPERATURES

The PESO certification requires the classification of the electrical equipment only.

Diplomatic supplies valves with PESO certified coils, suitable for application and installation in potentially explosive atmospheres. The mechanical construction of the coil housing is made in order to ensure its resistance to possible internal explosion and to avoid any explosion propagation to the outside environment, matching an “Ex db” type protection (explosion-proof coil).

Moreover, the solenoid is designed to maintain its surface temperature below the limits specified to the relevant class.

The supply always includes the operating and maintenance manual, that contains all the information needed for a correct use of the valve in potentially explosive environment.

3.1 - PESO classification

Certificate of conformity: P480801

The valves are suitable for applications and installations in potentially explosive atmospheres that fall within:

PESO Gb	*KPD2	equipment intended for use in areas in which explosive atmospheres caused by gases, vapours, mists are likely to occur occasionally. The means of protection relating to equipment in this category ensure the requisite level of protection, even in the event of frequently occurring disturbances or equipment faults which normally have to be taken into account.
---------	--------------	--

3.2 - PESO marking

There is a plate with the PESO mark on each coil.

*KPD2 valves	for gas	Ex db IIC T4 Gb (-40°C Ta +80°C)
*KPD2 /T5 valves	for gas	Ex db IIC T5 Gb (-40°C Ta +55°C)

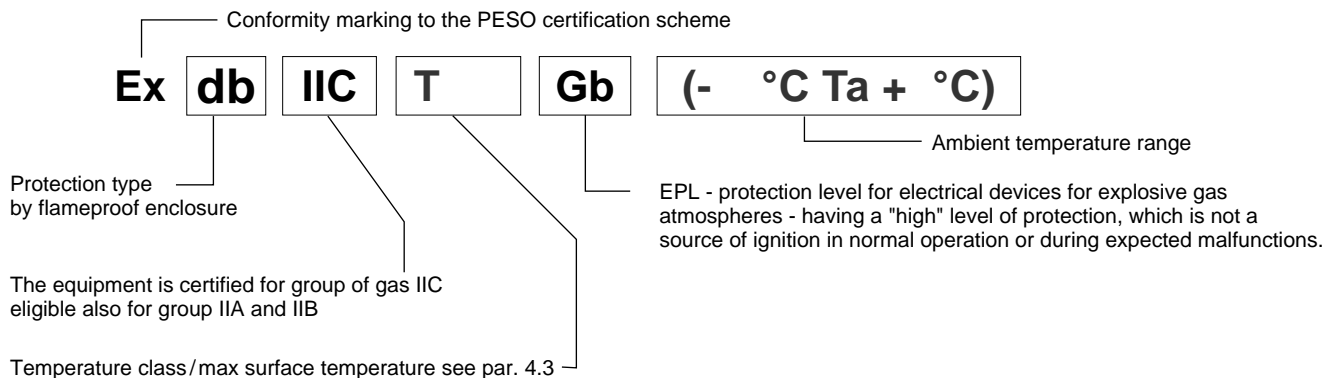

3.3 - Operating temperatures

These valves are classified according to their maximum surface temperature (EN 13463-1), which must be lower than the ignition temperature of the gases, vapors and dusts for which the area in which they will be used is classified.

Valves for surface plants can also be used for less limiting temperature classes (higher surface temperature allowed).

		temperature range	N and V seals	NL seals	Temperature class	eligible also for
PESO Gb	*KPD2	of ambient	-20 / +80 °C	-40 / +80 °C	T4 (gas)	T3, T2, T1
		of fluid				
	*KPD2 /T5	of ambient	-20 / +55 °C	-40 / +55 °C	T5 (gas)	T4, T3, T2, T1
		of fluid	-20 / +60 °C	-40 / +60 °C		

3.4 - Protection degree from atmospheric agents (IEC EN 60529)

Protection degree from atmospheric agents according to IEC EN 60529 is IP66/IP68.



DUPLOMATIC
MOTION SOLUTIONS
*a member of **DAIKIN** group*

DUPLOMATIC MS Spa

via Mario Re Depaolini, 24 | 20015 Parabiago (MI) | Italy
T +39 0331 895111 | E vendite.ita@duplomatic.com | sales.exp@duplomatic.com
duplomaticmotionsolutions.com