



DS(P)E*K*

EXPLOSION-PROOF PROPORTIONAL DIRECTIONAL VALVES ATEX, IECEx, PESO

DSE3K*	ISO 4401-03
DSPE5K*	CETOP P05
DSPE5RK*	ISO 4401-05
DSPE7K*	ISO 4401-07
DSPE8K*	ISO 4401-08
DSPE10K*	ISO 4401-10
DSPE11K*	ISO 4401-10 oversize ports

OPERATING PRINCIPLE

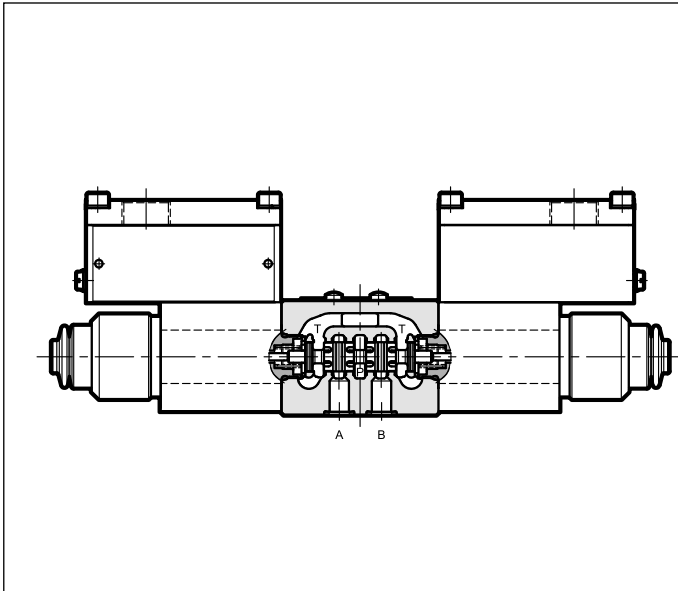

- These explosion-proof directional valves are available in size ISO 4401-03 for direct operated type. Pilot operated valves are available in CETOP P05, ISO 4401-05, ISO 4401-07, ISO 4401-08, ISO 4401-10 sizes and ISO 4401-10 size with oversize ports.
- They are compliant with ATEX, IECEx or PESO requirements and are suitable for use in potentially explosive atmospheres, for surface plants or mines.
- A low temperature version (up to -40 °C) is also available.
- The valves can be controlled directly by a current power supply or by means of an electronic control unit, to exploit valve performance to the full (see p. 20).
- The DSE3K* valves are supplied with a finishing surface treatment (zinc-nickel) suitable to ensure a salt spray resistance up to 600 hours; for DSPE*K* valves, this finishing is available upon request.
- **Details for classification, operating temperatures and electrical characteristics are in the technical data sheet 02 500 'Explosion proof classification'.**

PERFORMANCES

(obtained with viscosity of 36 cSt at 50 °C and electronic control card)

		DSE3K*	DSPE5K* DSPE5RK*	DSPE7K*	DSPE8K*	DSPE10K*	DSPE11K*
Max operating pressure: P - A - B ports T ports	bar	350 210	350 see point 8				320 see p. 8
Rated flow rate Δp 10 bar P-T	l/min	26	80	150	300	800	1000
Step response		see point 7					
Hysteresis	% of Q max	<6% (PWM 200 Hz)	< 4% (PWM 100 Hz)				
Repeatability	% of Q max	< $\pm 1.5\%$	< $\pm 2\%$				
Electrical characteristics		see point 3					
Temperature ranges (ambient and fluid)		see data sheet 02 500					
Fluid viscosity range	cSt	10 \div 400					
Fluid contamination degree		According to ISO 4406:1999 class 18/16/13					
Recommended viscosity	cSt	25					
Mass single solenoid valve double solenoid valve	kg	1.9 3.2	6.6 7.8	8.2 9.3	15.7 16.7	43.1 44.3	40.4 41.5

1 - IDENTIFICATION OF DIRECT OPERATED VALVES

	D	S	E	3	-			/	10	-		K9	/	
--	----------	----------	----------	----------	---	--	--	---	-----------	---	--	-----------	---	--

Direct operated solenoid valve

Electric proportional control

Size: ISO 4401-03

Explosion-proof certification: **See table 1.1**

Spool type:
C = closed center
A = open center

Spool nominal flow rate (see table p. 1.2)

Solenoid position
 (omit for double solenoid version):
SA = 1 solenoid for cross configuration
SB = 1 solenoid for parallel configuration

Series No.:
 (the overall and mounting dimensions do not change from 10 to 19)

Seals:
 For temperature range -20 / +80 °C
N = NBR seals for mineral oil (**standard**)
V = FPM seals for special fluids
 For temperature range -40 / +80 °C
NL = seal for low temperatures (for mineral oil)

Option: **/T5**
 version in T5 temperature class.
 Omit if not required.

Manual override:
CM = boot protected **standard for both N and V seals**
 not available for NL seals
CB = blind ring nut **standard for NL seals**
 available upon request for both N and V seals
CK = knob manual override
CH = lever manual override.
 Dimensions for CB and CH at p. 18

Connection type for cable gland upper connection:
T01 = M20x1.5 - ISO 261
T02 = Gk 1/2 - UNI EN 10226-2
T03 = 1/2" NPT - ANSI B1.20.1 (ex ANSI B2.1)
 side connection:
S01 = M20x1.5 - ISO 261
S02 = Gk 1/2 - UNI EN 10226-2
S03 = 1/2" NPT - ANSI B1.20.1 (ex ANSI B2.1)
S04 = M16x1.5 - ISO 261

Coil electrical connection: junction box

Nominal solenoid voltage:
D12 = 12V DC
D24 = 24V DC

NOTE: Valves are supplied with zinc-nickel surface treatment, that is suitable to ensure a salt spray resistance up to 600 h (test operated according to UNI EN ISO 9227 standards and test evaluation operated according to UNI EN ISO 10289 standards).

Version with monobloc steel coil
 Standard coils are made of zinc-nickel steel, with anodized aluminium junction box on it.
 Monobloc coils **MD24K9S01** completely made of steel are available upon request. They have zinc-nickel treatment, power supply voltage D24 and cable gland connection type S01. Other variants for voltage and cable gland connection are available, always on request.

1.1 - Names of valves per certification

	ATEX		IECEX		PESO	
for gases for dusts	KD2	II 2GD	KXD2	IECEX Gb IECEX Db	KPD2	PESO Gb not applicable for dust
for mines	KDM2	I M2	KXDM2	IECEX Mb	not applicable for mines	

NOTE: Refer to the technical data sheet 02 500 for marking, operating temperatures and available versions.

1.2 - Available configurations

Valve configuration depends on the combination of the following elements:
number of proportional solenoids, spool type, nominal flow rate.

2 solenoids configuration:
3 positions with spring centering

"SA" configuration: 1 solenoid on side A.
2 positions (central + external) with
return spring

"SB" configuration: 1 solenoid on side B.
2 positions (central + external) with
return spring

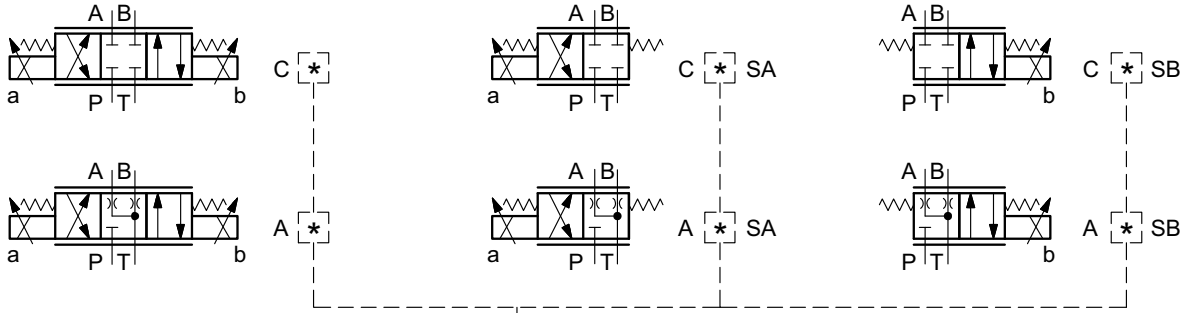

*	Nominal flow with $\Delta p 10$ bar P→T
01	1 l/min
04	4 l/min
08	8 l/min
16	16 l/min
16/08	16 (P→A) / 08 (B→T) l/min
26	26 l/min
26/13	26 (P→A) / 13 (B→T) l/min



2 - CHARACTERISTIC CURVES OF DIRECT OPERATED VALVES

(obtained with mineral oil with viscosity of 36 cSt at 50°C and electronic control card)

Typical flow control characteristics, according to current supply to the solenoid.
The reference Δp values are measured between ports P and T on the valve.

C01 / A01

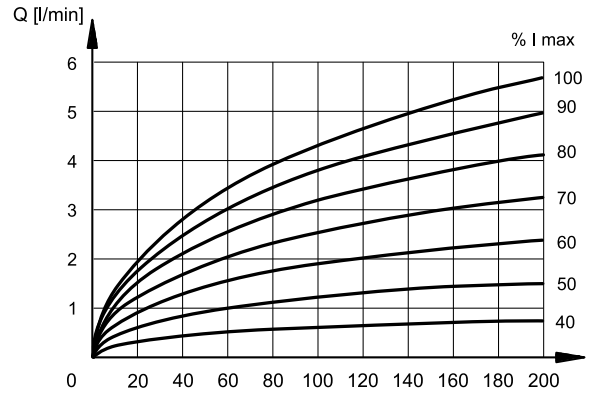
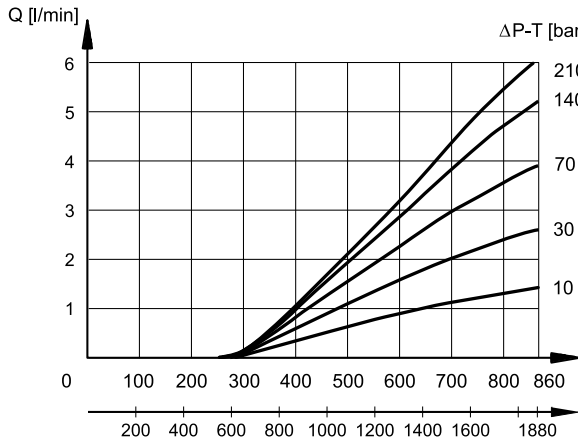

C04 / A04

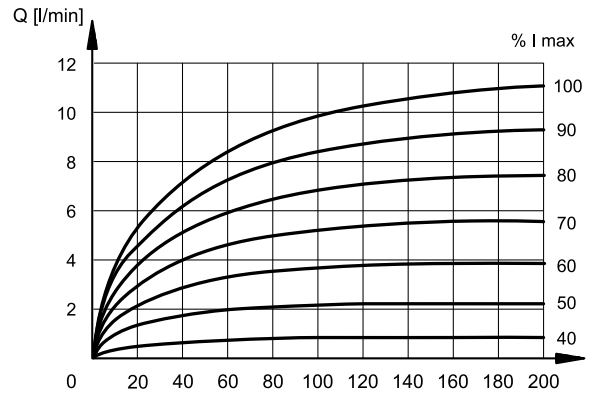
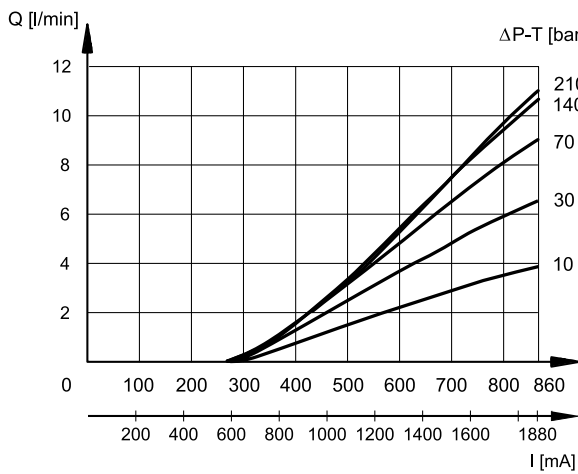

C08 / A08

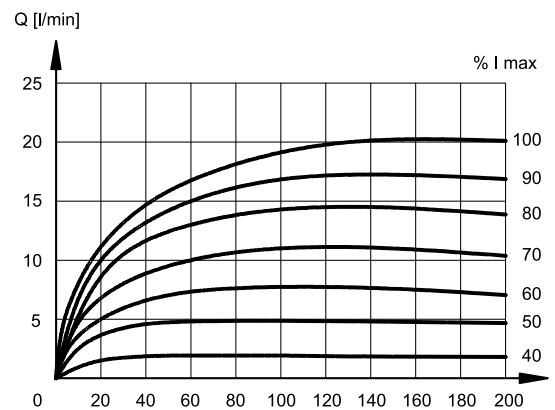
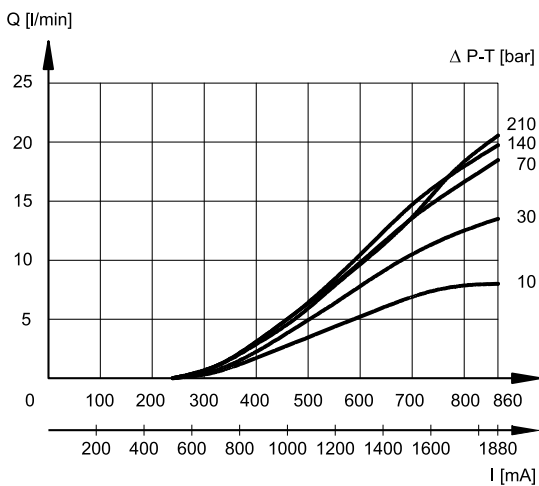



DS(P)E*K*

C16 / A16

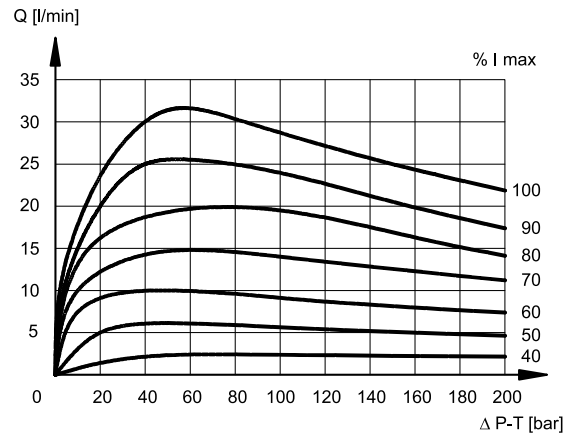
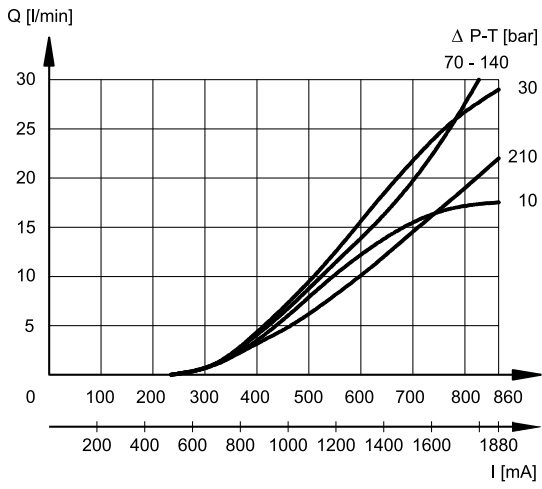

C26 / A26

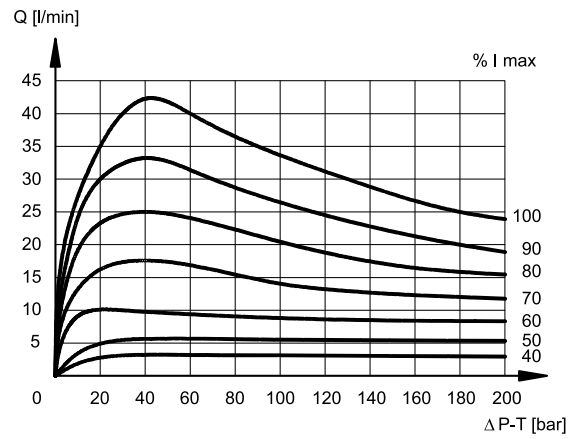
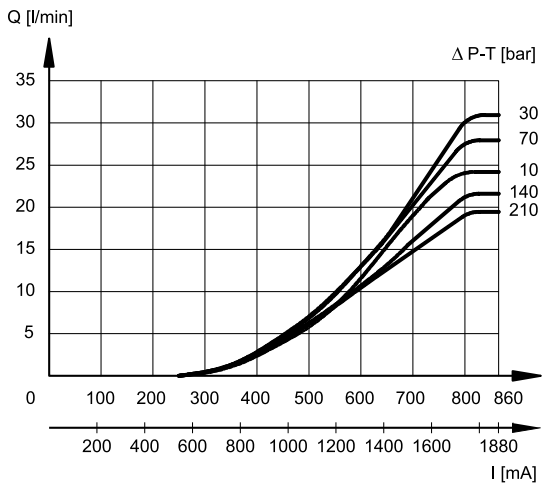

3 - ELECTRICAL CHARACTERISTICS

(values ± 5%)

NOMINAL VOLTAGE	V DC	12	24
RESISTANCE (AT 20°C)	Ω	3.8	15.6
NOMINAL CURRENT	A	1.88	0.86

DUTY CYCLE	100%
ELECTROMAGNETIC COMPATIBILITY (EMC)	According to 2014/30/EU
CLASS OF PROTECTION: Atmospheric agents Coil insulation (VDE 0580)	IP66/IP68 class H

3.1 - Wiring

In order to realise the electrical connection of the coil, it is necessary to access the terminal block (1) unscrewing the 4 screws (2) that fasten the cover (3) with the box (4) that contains the terminal block.

The electrical connection is polarity-independent.

By doing electrical connection, it is important to connect also the grounding point (5) in the terminal block box (M4 screws), through suitable conductors with the general grounding line of the system.

On the external body of the coil, there is a grounding point (6) (M4 screw) that makes it possible to ensure equipotentiality between the valve and the general grounding line of the system; connecting this point, the regulation of the EN 13463-1 standard that requires verifying the equipotentiality of the elements included in a potentially explosive environment (the maximum resistance between the elements must be 100 Ω) is guaranteed.

At the end of the electrical wiring, it is necessary to reassemble the cover (3) on the box (4), checking the correct positioning of the seal located in the cover seat and fastening the 4 M5 screws with a torque of 4.9÷6 Nm.

Electrical wiring must be done in compliance with standards about protection against explosion hazards.

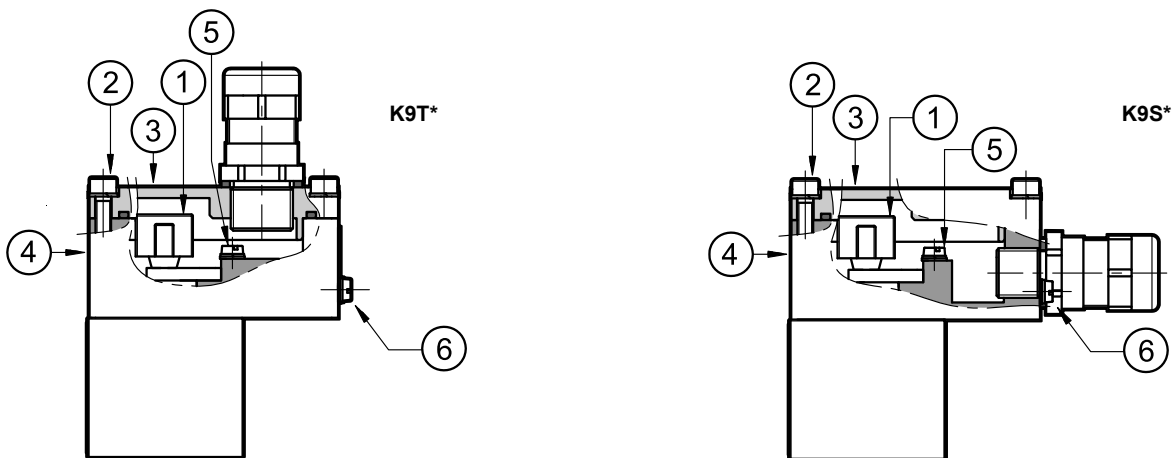

Characteristics of the cables connectable for wiring are indicated in the table below:

Function	Cable section
Operating voltage cables connection	max 2.5 mm ²
Connection for internal grounding point	max 2.5 mm ²
Connection for external equipotential grounding point	max 6 mm ²

Cables for wiring must be non-armoured cables, with external covering sheath and must be suitable for use in environments with temperatures from - 20 °C to +110 °C (for valves either with N or V seals) or from - 40 °C to +110 °C (for valves with NL seals).

Cable glands (which must be ordered separately, see point 19) make it possible to use cables with external diameter between 8 and 10 mm.

3.2 - Electrical diagrams

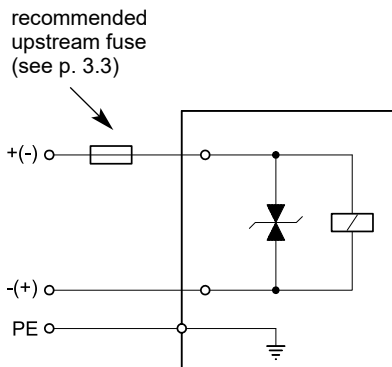

3.3 - Overcurrent fuse and switch-off voltage peak

Upstream of each valve, an appropriate fuse (max 3 x I_n according to IEC 60127) or a protective motor switch with short-circuit and thermal instantaneous tripping, as short-circuit protection, must be connected. The cut-off power of the fuse must correspond or exceed the short circuit current of the supply source. The breaking capacity of the fuse link shall be the same as or higher than the maximum short-circuit current expected to occur at the place of installation (normally 1500 A).

The fuse or the protective motor must be placed outside the dangerous area or they must be protected with an explosion-proof covering.

In order to safeguard the electronic device to which the valve is connected, there is a protection circuit in the coil that reduces voltage peaks, which can occur when inductances are switched off.

The table shows the type of fuse recommended according to the nominal voltage of the valve and to the value of the voltage peaks reduction.

Coil type	Nominal voltage [V]	Rated current [A]	Recommended pre-fuse characteristics medium time-lag according to DIN 41571 [A]	Maximum voltage value upon switch off [V]	Suppressor circuit
D12	12	1.88	2.5	- 49	Transient voltage suppressor bidirectional
D24	24	0.86	1.25	- 49	

4 - DSE3K* WITH UPPER CONNECTION - OVERALL AND MOUNTING DIMENSIONS

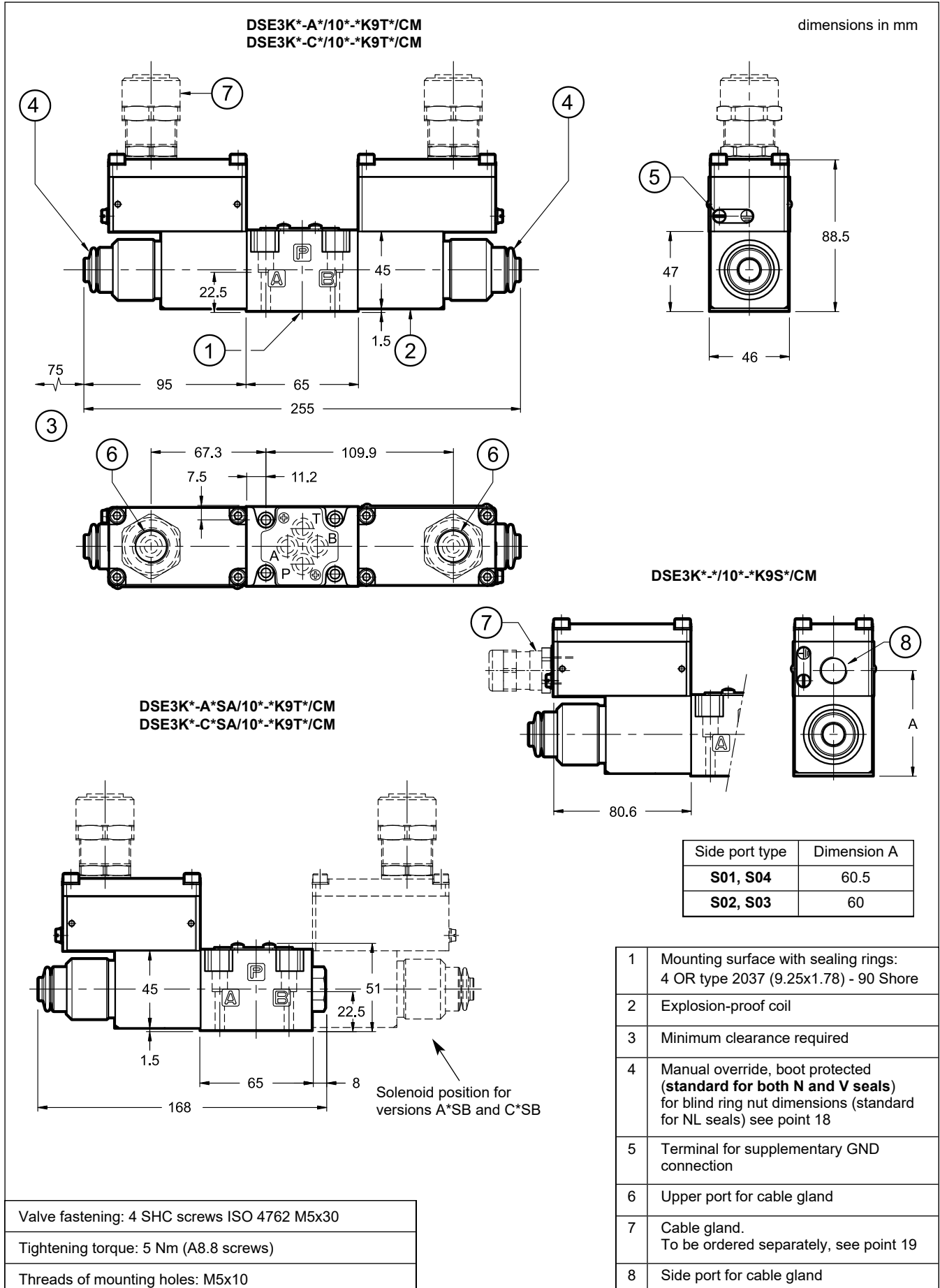

5.1 - Configurations

The valve configuration depends on the combination of the following elements: number of proportional solenoids, spool type, rated flow.

Configuration 2 solenoids:
3 positions with spring centering

1 solenoid for cross configuration "SA":
2 positions (central + external)
with return spring

1 solenoid for parallel configuration "SB":
2 positions (central + external)
with return spring

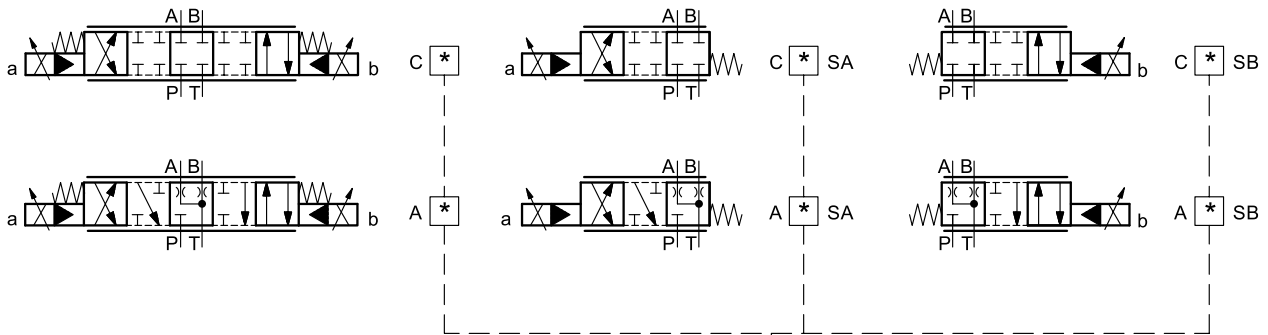

valve type	*	nominal flow rate with Δp 10 bar P-T
DSPE5K*	80	80 l/min
DSPE5RK*	80/40	80 (P-A) / 40 (B-T) l/min
DSPE7K*	100	100 l/min
	150	150 l/min
DSPE8K*	150/75	150 (P-A) / 75 (B-T) l/min
	200	200 l/min
DSPE8K*	300	300 l/min
	300/150	300 (P-A) / 150 (B-T) l/min
DSPE10K*	350	350 l/min
	500	500 l/min
	500/250	500 (P-A) / 250 (B-T) l/min
DSPE11K*	800	800 l/min
DSPE11K*	1000	1000 l/min

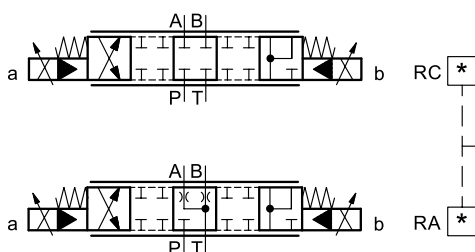

valve type	*	nominal flow rate with Δp 10 bar P-T
DSPE7K*	150/75	150 (P-A, A-T) / 75 (P-B, B-P) l/min
DSPE8K*	300/150	300 (P-A, A-T) / 150 (P-B, B-P) l/min
DSPE10K*	500/250	500 (P-A, A-T) / 250 (P-B, B-P) l/min

6 - CHARACTERISTIC CURVES OF PILOT OPERATED SOLENOID VALVES

(obtained with mineral oil with viscosity of 36 cSt at 50°C and electronic control card)

Typical flow rate control curves at constant Δp according to current supply to the solenoid, measured for the available spool types.

The reference Δp values are measured between valve ports P and T.

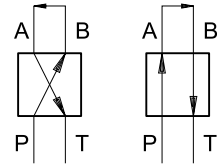

6.1 - Characteristic curves DSPE5K* and DSPE5RK

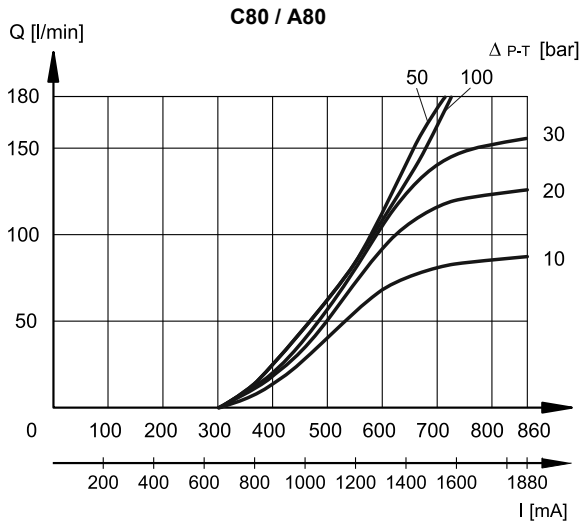

6.2 - Characteristic curves DSPE7K*

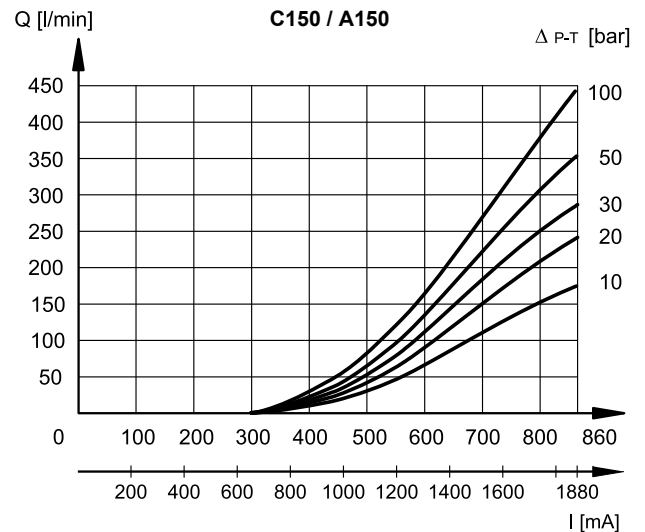
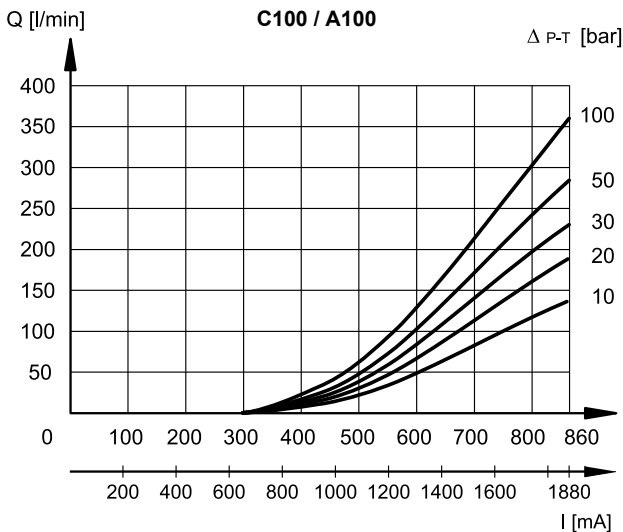

6.3 - Characteristic curves DSPE8K*

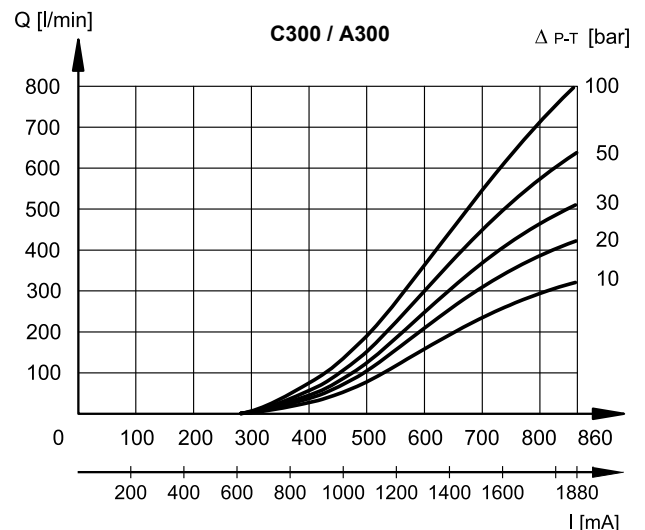
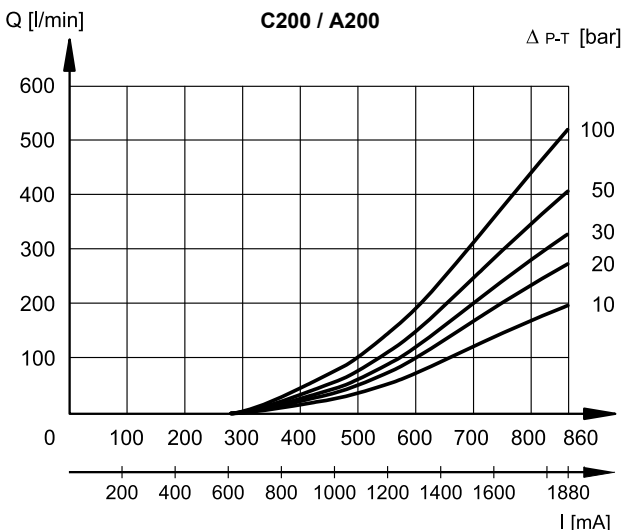



6.4 - Characteristic curves DSPE10K*

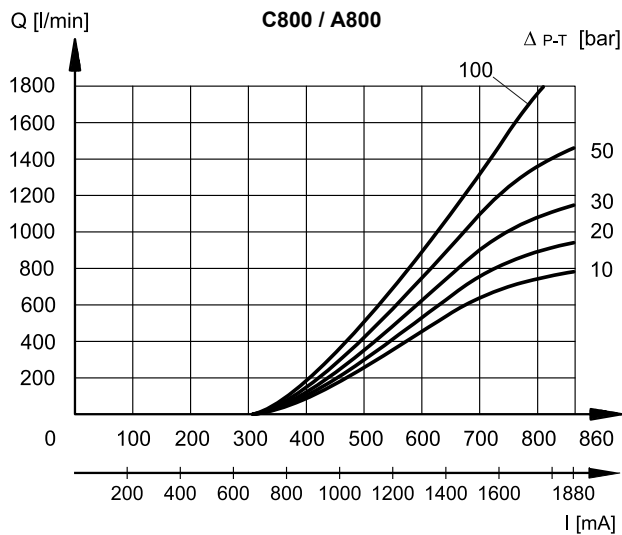
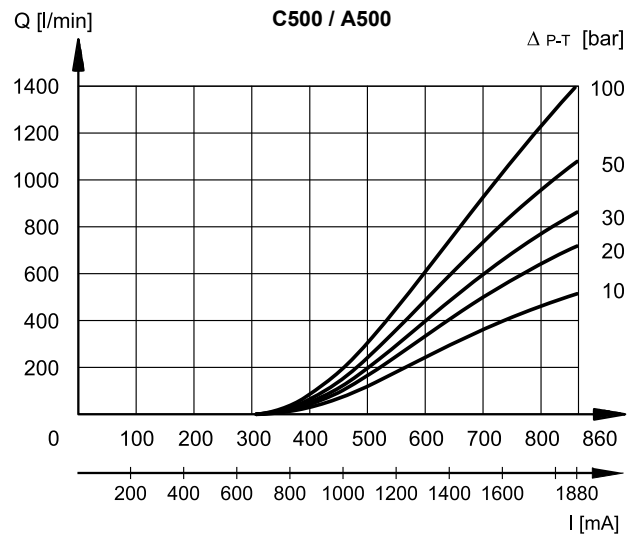
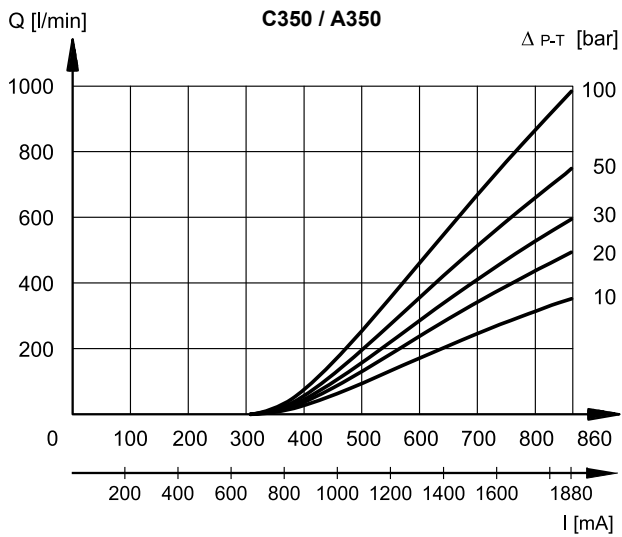

6.5 - Characteristic curves DSPE11K*

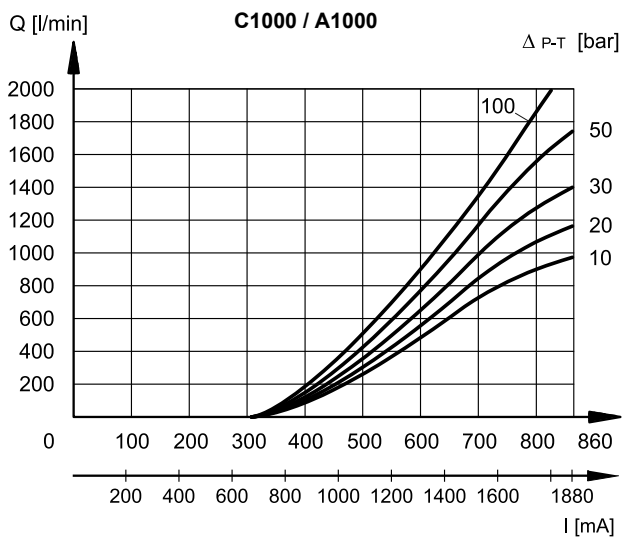



7 - STEP RESPONSE

(obtained with mineral oil with viscosity of 36 cSt at 50°C and electronic control card)

Step response is the time taken for the valve to reach 90% of the set pressure value following a step change of reference signal.

The table shows the typical step response tested with static pressure 100 bar.

REFERENCE SIGNAL	0 → 100%	100 → 0%
	Step response [ms]	
DSE3K*	50	40
DSPE5K* and DSPE5RK*	50	40
DSPE7K*	80	50
DSPE8K*	100	70
DSPE10K*	200	120

8 - HYDRAULICS CHARACTERISTICS

(obtained with mineral oil with viscosity of 36 cSt at 50°C and electronic control card)

		DSPE5K* DSPE5RK*	DSPE7K*	DSPE8K*	DSPE10K*	DSPE11K*
Max flow rate	l/min	180	450	800	1800	2000
Pilot supply flow requested with operation 0 →100%	l/min	2.1	2.4	5.5	6.5	6.5
Pilot supply volume requested with operation 0 →100%	cm ³	1.7	3.2	9.2	21.6	21.6

PRESSURES	MIN	MAX
Piloting pressure on X port	30	210 (NOTE)
Pressure on T port with internal drain	–	10
Pressure on T port with external drain	–	250

NOTE: if the valve operates with higher pressures it is necessary to use the version with external pilot and reduced pressure. Otherwise, the valve with internal pilot and pressure reducing valve with 30 bar fixed adjustment can be ordered.

Add the letter **Z** to the identification code to order this option (see p. 5).

9 - PILOT AND DRAIN

DSPE* valves are available with pilot and drain both internal or external. The version with external drain allows a higher back pressure on the unloading. The version with external pilot with reduced pressure must be used when higher pressures are needed.

NOTE: The configuration of pilots and drains must be chosen when ordering. Subsequent modifications are allowed only to specialized operators with authorization and in factory.

TYPE OF VALVE	Plug assembly	
	X	Y
IE internal pilot and external drain	NO	YES
II internal pilot and internal drain	NO	NO
EE external pilot and external drain	YES	YES
EI external pilot and internal drain	YES	NO

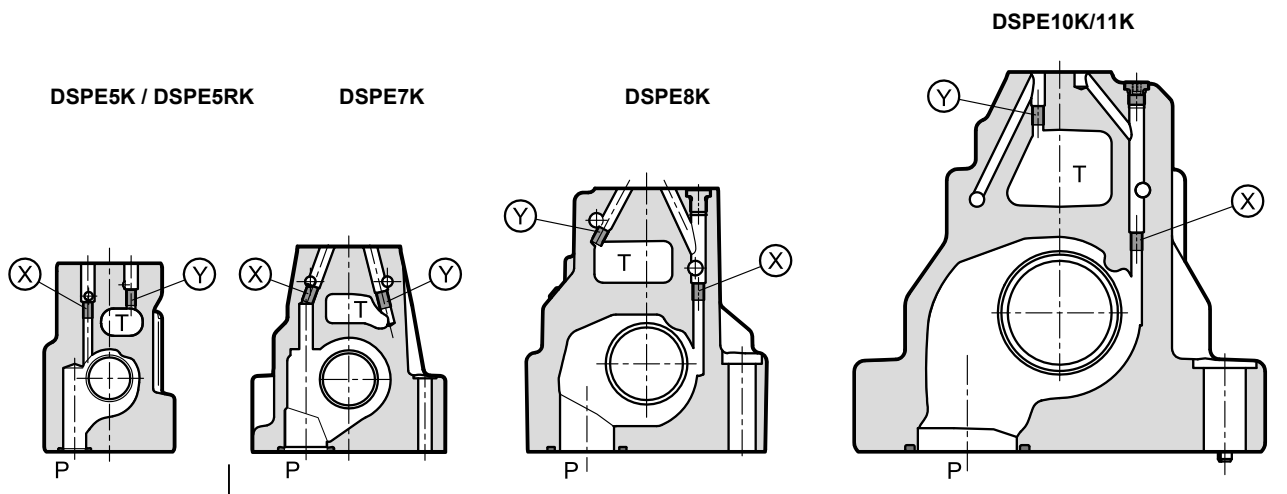

X: plug M5x6 for external pilot
Y: plug M5x6 for external drain

X: plug M6x8 for external pilot
Y: plug M6x8 for external drain

9.1 - Z type pilot supply: internal pilot supply with pressure reducing valve

The Z type pilot supply consists of an arrangement with internal pilot and 30 bar supply pressure to the pilot stage, by means of a fixed adjustment pressure reducing valve placed between the main stage and the pilot valve.

Consider an increase of 40 mm in height for valves ordered with Z option.

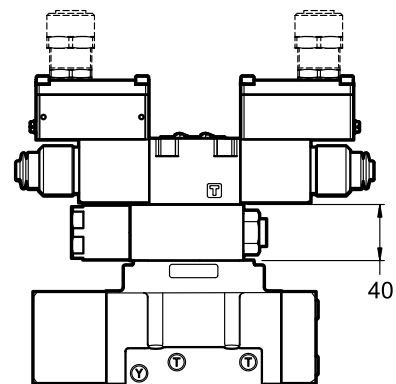

10 - DSPE5K* / DSPE5RK* WITH UPPER CONNECTION - OVERALL AND MOUNTING DIMENSIONS

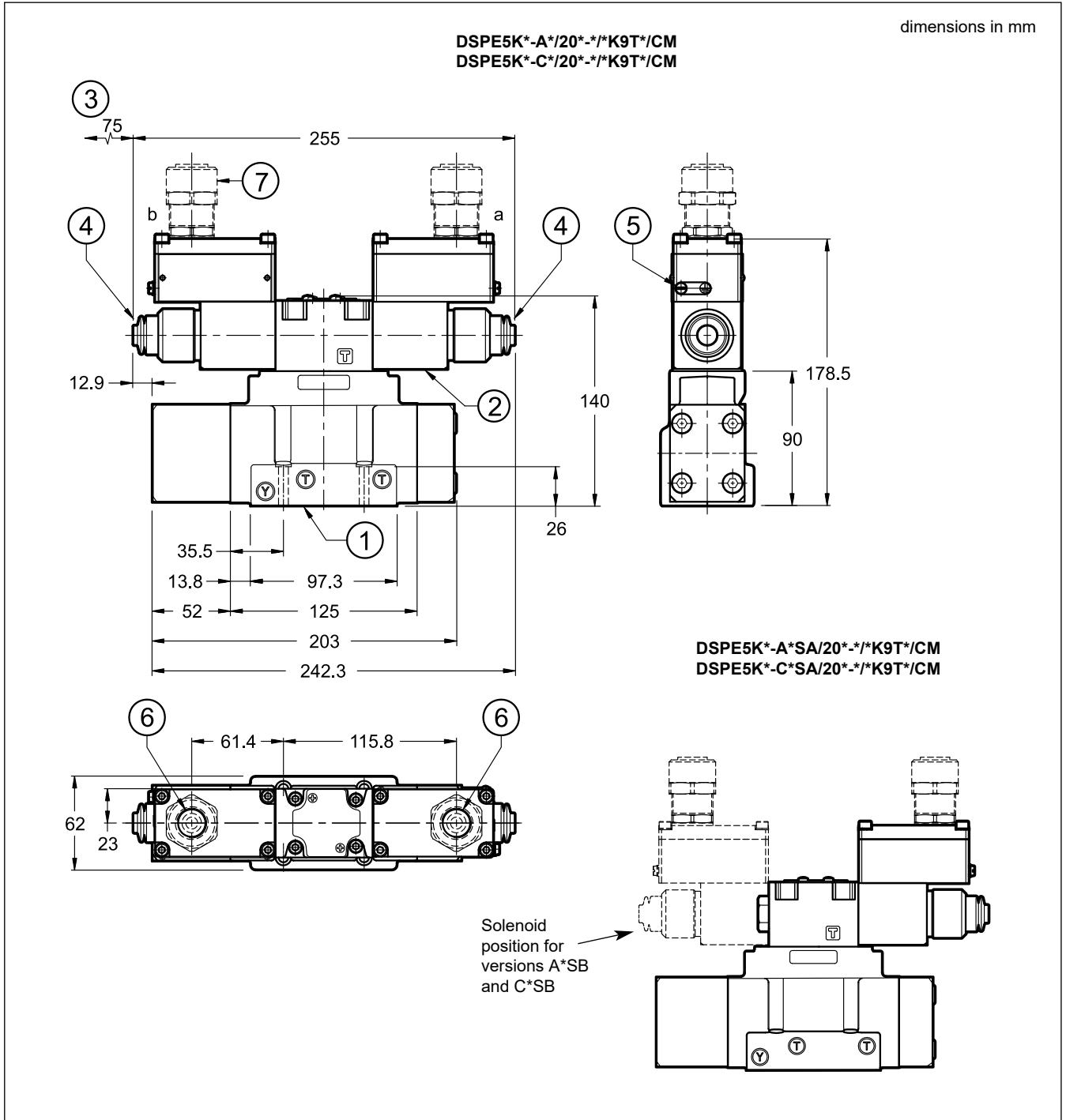

1	Mounting surface with sealing rings: 5 OR type 2050 (12.42x1.78) - 90 Shore 2 OR type 2037 (9.25x1.78) - 90 Shore
2	Explosion-proof coil
3	Minimum clearance required
4	Manual override, boot protected (standard for both N and V seals) - for blind ring nut dimensions (standard for NL seals) see point 18
5	Terminal for supplementary GND connection
6	Upper port for cable gland
7	Cable gland. To be ordered separately, see point 19

NOTE: for side port cable gland see point 14.

Valve fastening: 4 SHC ISO 4762 screws M6x35
Tightening torque: 8 Nm (A8.8 screws)
Threads of mounting holes: M6x10

11 - DSPE7K* WITH UPPER CONNECTION - OVERALL AND MOUNTING DIMENSIONS

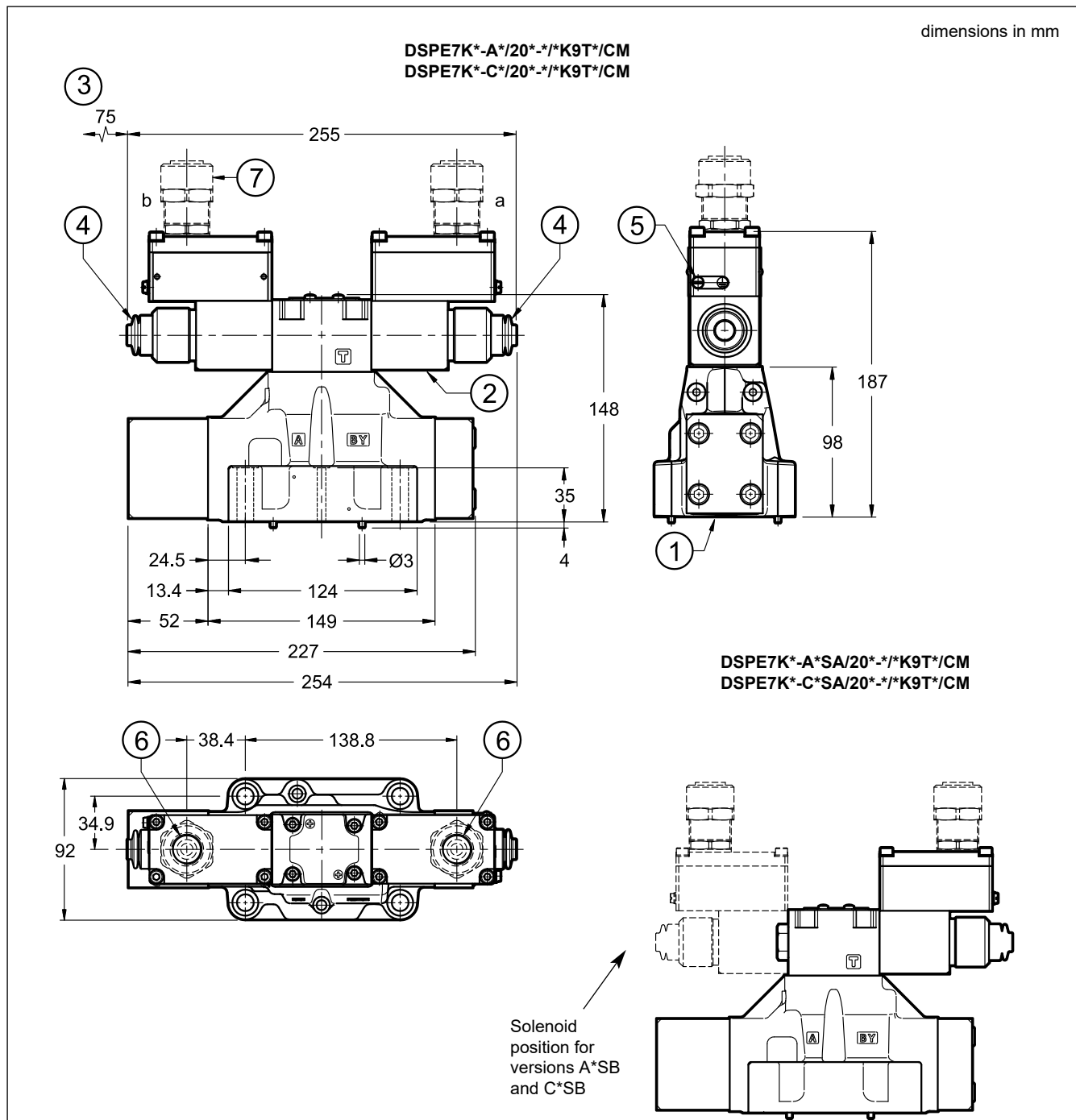

1	Mounting surface with sealing rings: 4 OR type 130 (22.22x2.62) - 90 Shore 2 OR type 2043 (10.82x1.78) - 90 Shore
2	Explosion-proof coil
3	Minimum clearance required
4	Manual override, boot protected (standard for both N and V seals) - for blind ring nut dimensions (standard for NL seals) see point 18
5	Terminal for supplementary GND connection
6	Upper port for cable gland
7	Cable gland. To be ordered separately, see point 19

NOTE: for side port cable gland see point 14.

Valve fastening: 4 SHC screws ISO 4762 M10x50 2 SHC screws ISO 4762 M6x50
Tightening torque: M10x50: 40 Nm (A8.8 screws) M6x50: 8 Nm (A8.8 screws)
Threads of mounting holes: M6x18; M10x18

12 - DSPE8K* WITH UPPER CONNECTION - OVERALL AND MOUNTING DIMENSIONS

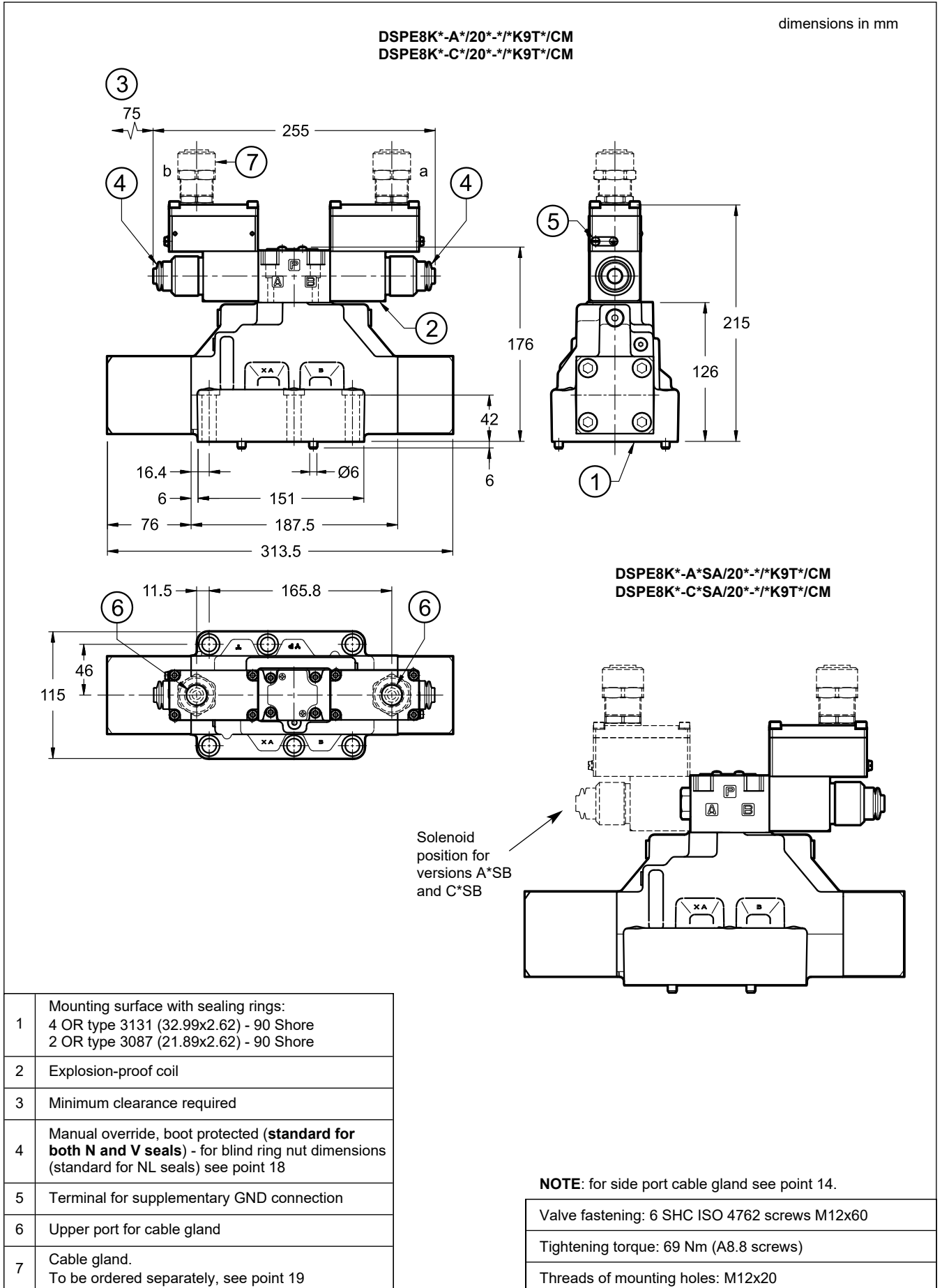

13 - DSPE10K* / DSPE11K* WITH UPPER CONNECTION - OVERALL AND MOUNTING DIMENSIONS

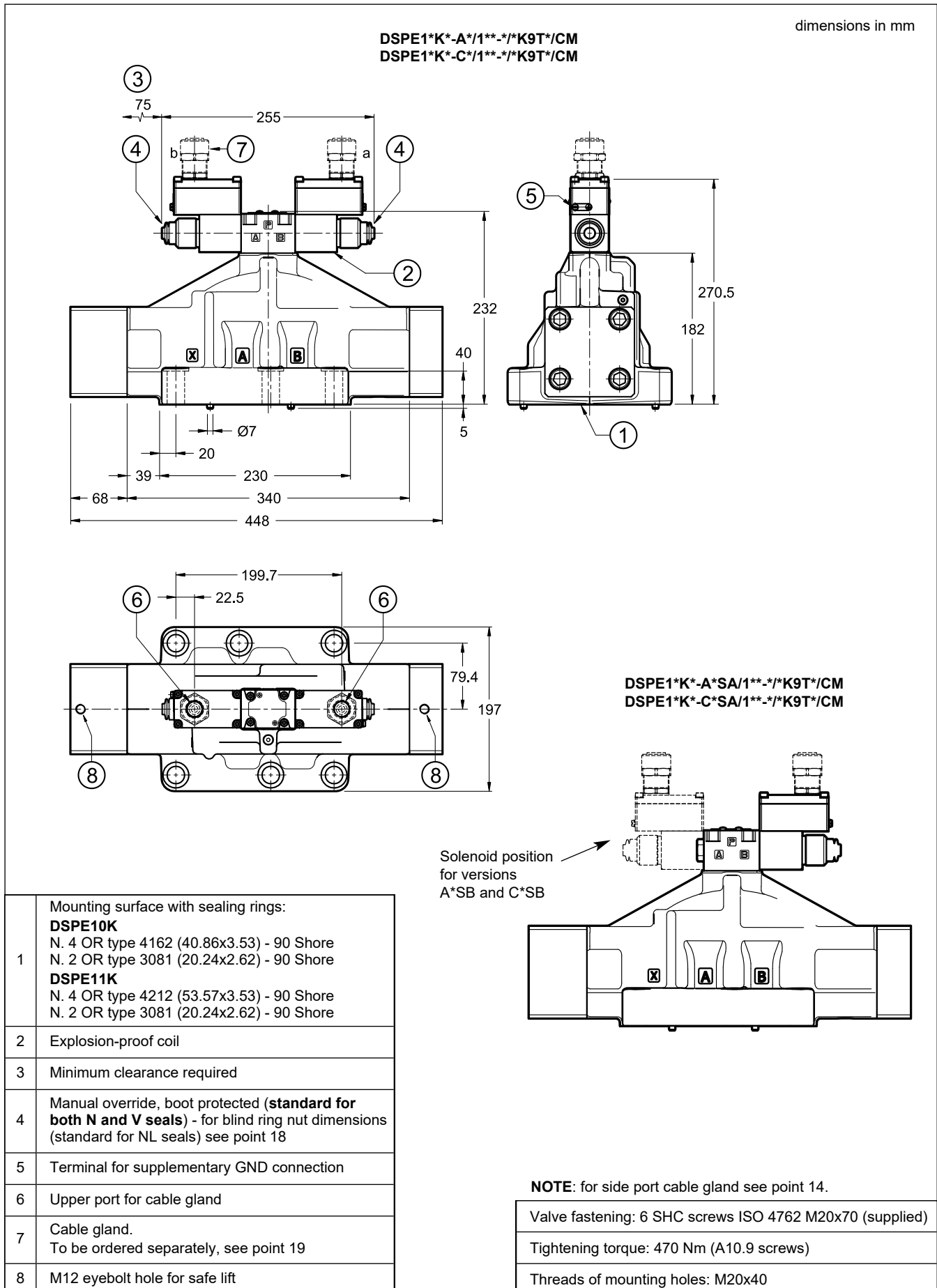

14 - DSPE*K*-*K9S* WITH SIDE CONNECTION - OVERALL AND MOUNTING DIMENSIONS

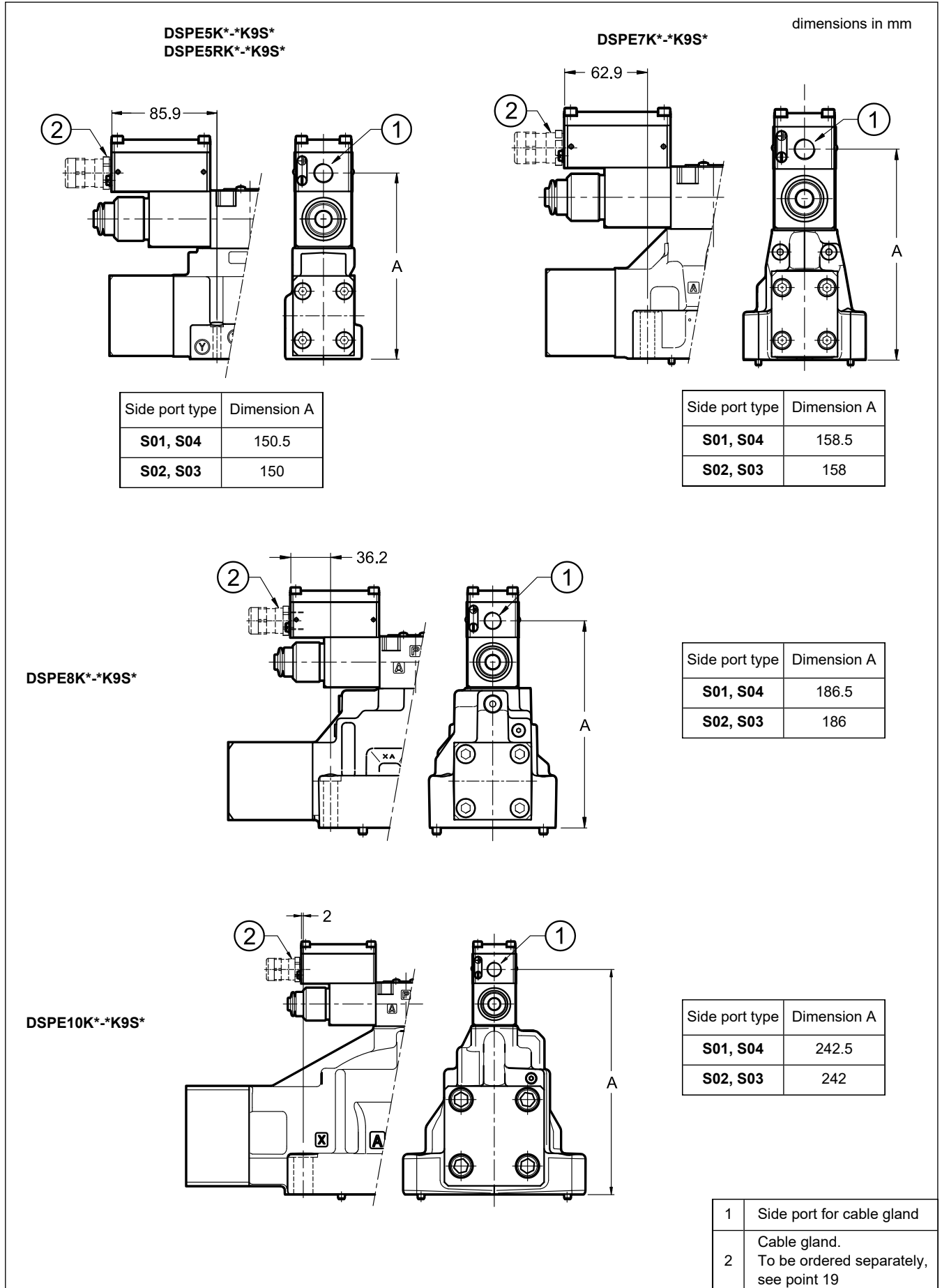

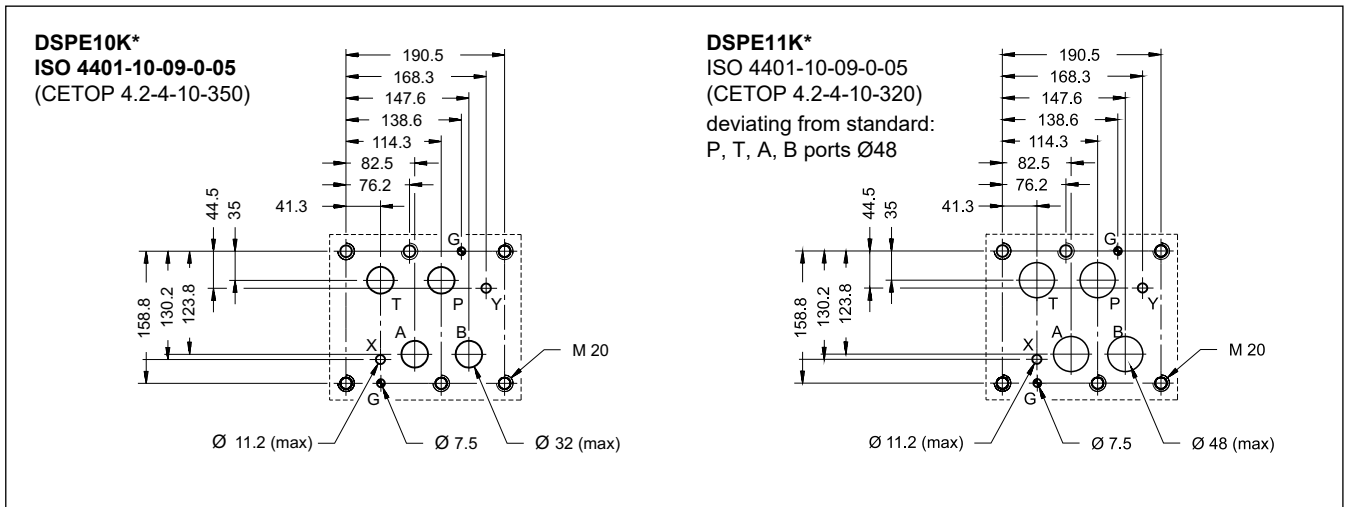

16 - HYDRAULIC FLUIDS

Use mineral oil-based hydraulic fluids HL or HM type, according to ISO 6743-4. For these fluids, use NBR seals (code N). For fluids HFDR type (phosphate esters) use FPM seals (code V). For the use of other fluid types such as HFA, HFB, HFC, please consult our technical department. Using fluids at temperatures higher than 80 °C causes a faster degradation of the fluid and of the seals characteristics. The fluid must be preserved in its physical and chemical characteristics.

17 - INSTALLATION



Installation must adhere to instructions reported in the *Use and Maintenance manual*, always attached to the valve. Unauthorized interventions can be harmful to people and goods because of the explosion hazards present in potentially explosive atmospheres.

The valves can be installed in any position without impairing correct operation.

Valve fastening takes place by means of screws or tie rods, laying the valve on a lapped surface, with values of planarity and smoothness that are equal to or better than those indicated in the drawing.

If the minimum values of planarity or smoothness are not met, fluid leakages between valve and mounting surface can easily occur.

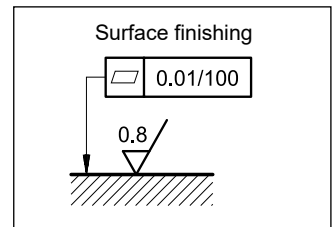

18 - MANUAL OVERRIDES

18.1 - CB - Blind ring nut

The metal ring nut protects the solenoid tube from atmospheric agents and isolates the manual override from accidental operations. The ring nut is tightened on a threaded fastener that keeps the coil in its position even without the ring nut.

To access the manual override loose the ring nut and remove it; then reassemble hand tightening, until it stops.

Activate the manual override always and only with non-sparking tools suitable for use in potentially explosive atmospheres.

More information on safe use of explosion-proof components is provided in the instruction manual, always supplied with the valve.



CAUTION! The manual override doesn't allow any proportional regulation; indeed using this kind of override, the main stage spool will open completely and the whole inlet pressure will pass through A or B line.

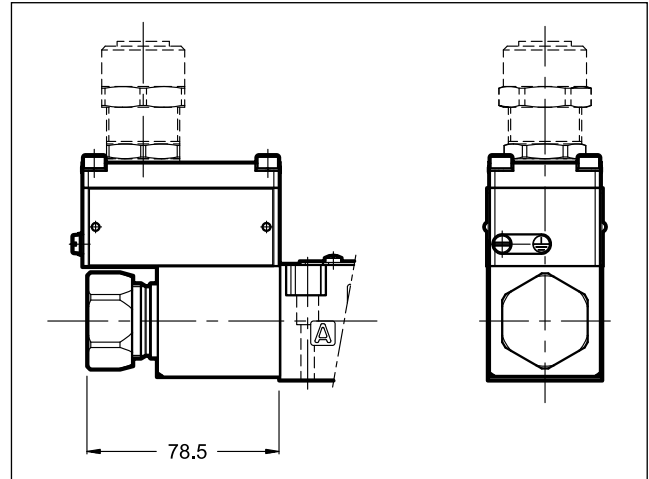

18.2 - CK Knob manual override

When the set screw is screwed and its point is aligned with the edge of the knob, tighten the knob till it touches the spool: in this position the override is not engaged and the valve is de-energized. After adjusting the override, tighten the set screw in order to avoid the knob loosening. Available for DC valves only.

Spanner: 3 mm

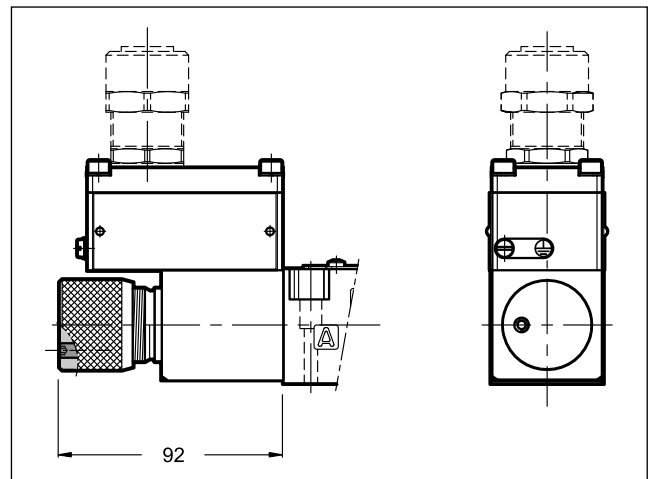

18.3 - CH - Lever manual override

The seals choice leads the type of the standard ring nut to be mounted. The lever device is always placed at valve side A.

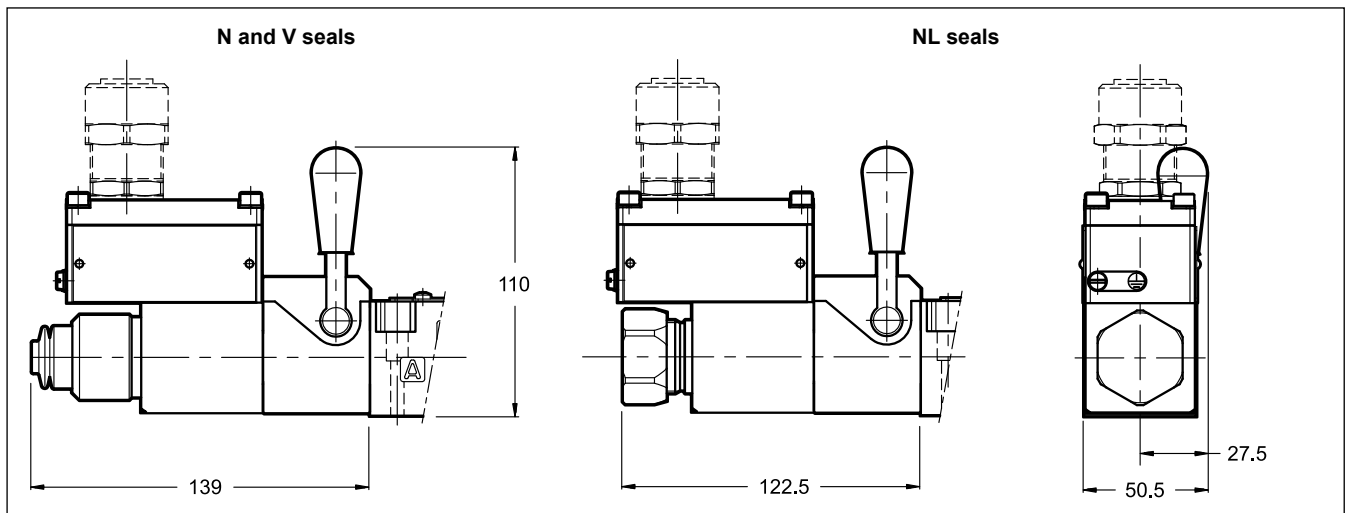

19 - CABLE GLANDS

Cable glands must be ordered separately; Duplomatic offers some types of cable glands with the following features:

- version for non-armoured cable, external seal on the cable (suitable for $\varnothing 8+10$ mm cables);
- ATEX II 2GD, I M2; IECEx Gb, Db, Mb;
- cable gland material: nickel brass
- inner rubber tip material: silicone
- ambient temperature range: $-65\text{ }^{\circ}\text{C} \div +220\text{ }^{\circ}\text{C}$
- protection degree: IP66/IP68

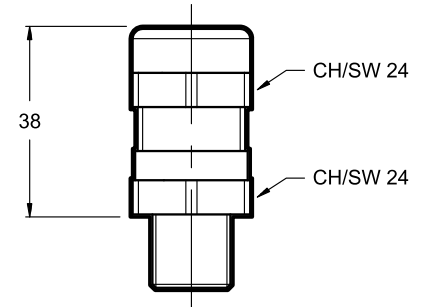

To order the desired cable glands, specify description, code and quantity.

Description: CGK2/NB-01/10

Code: 3908108001

M20x1.5 - ISO 261 male thread, suitable for coils with T01 and S01 connections. It is supplied equipped with copper washer, that must be assembled between the cable gland and the coil, so as to ensure IP66/IP68 protection degree.

Tightening torque: $45 \div 50$ Nm

Description: CGK2/NB-02/10

Code: 3908108002

Gk 1/2 - UNI EN 10226-2 male thread, suitable for coils with T02 and S02 connections. The customer must apply LOCTITE® 243™ threadlocker or similar between the cable gland connection thread and the coil in order to ensure IP66/IP68 protection degree.

Tightening torque: $20 \div 25$ Nm

Description: CGK2/NB-03/10

Code: 3908108003

1/2" NPT - ANSI B1.20.1 (ex ANSI B2.1), suitable for coils with T03 and S03 connections. The customer must apply LOCTITE® 243™ threadlocker or similar between the cable gland connection thread and the coil in order to ensure IP66/IP68 protection degree.

Tightening torque: $20 \div 25$ Nm

Description: CGK2/NB-04/10

Code: 3908108004

M16x1.5 - ISO 261 male thread, suitable for coils with S04 connection. It is supplied equipped with copper washer, that must be assembled between the cable gland and the coil, so as to ensure IP66/IP68 protection degree.

Tightening torque: $45 \div 50$ Nm

20 - ELECTRONIC CONTROL UNITS

DSE3K*-*SA, DSE3K*-*SB

EDM-M112	for solenoid 24V DC	DIN EN 50022 rail mounting	see cat. 89 252
EDM-M142	for solenoid 12V DC		

NOTE: electronic control units offered are not explosion proof certified; therefore, they must be installed outside the classified area.

DSE3K*-A*, DSE3K*-C*

EDM-M212	for solenoid 24V DC	DIN EN 50022 rail mounting	see cat. 89 252
EDM-M242	for solenoid 12V DC		

DSPE*K*-*SA, DSPE*K*-*SB

EDM-M111	for solenoid 24V DC	DIN EN 50022 rail mounting	see cat. 89 252
EDM-M141	for solenoid 12V DC		

DSPE*K*-A*, DSPE*K*-C*

EDM-M211	for solenoid 24V DC	DIN EN 50022 rail mounting	see cat. 89 252
EDM-M241	for solenoid 12V DC		



DS(P)E*K*

21 - SUBPLATES

(see catalogue 51 000)

No subplates are available for DSPE5RK*, DSPE10K* and DSPE11K*.

	DS3K*	DSP5K*	DSP7K*	DSP8K*
Type with rear ports	PMMD-AI3G	PME4-AI5G	PME07-AI6G	-
Type with side ports	PMMD-AL3G	PME4-AL5G	PME07-AL6G	PME5-AL8G
P, T, A, B ports dimensions	3/8" BSP	3/4" BSP	1" BSP	1 1/2" BSP
X, Y ports dimensions	-	1/4" BSP	1/4" BSP	1/4" BSP

NOTE: Subplates (to be ordered separately) contain neither aluminium nor magnesium at a rate higher than the value allowed by norms according to ATEX directive for category II 2GD and I M2.

The user will bear to do the complete assessment of the ignition risk that can occur from the relative use in potentially explosive environments.

EXPLOSION-PROOF CLASSIFICATION

for

SOLENOID AND PROPORTIONAL VALVES

ref. catalogues:

pressure control valves

RQM*K*-P	21 515
P*E*K*	81 316
ZDE3K*	81 515
DZCE*K*	81 606

flow control valves

QDE3K*	82 225
---------------	---------------

directional valves

D*K*	41 515
DT3K*	42 215
DS(P)E*K*	83 510

GENERAL INFO

This informative technical datasheet displays information about **classification and marking** of Duplomatic explosion-proof valves range.

Duplomatic MS offers valves with the following certifications:

ATEX	II 2G	II 2D	I M2
IECEX	Gb	Db	Mb
PESO	Gb		

Instructions for use and maintenance can be found in the related manuals, always supplied together with valves.



1 - ATEX CLASSIFICATION AND TEMPERATURES

Diplomatic certificates the combination valve-coil for the valves suitable for application and installation in potentially explosive atmospheres, according to ATEX directive; the supply always includes the declaration of conformity to the directive and the operating and maintenance manual, that contains all the information needed for a correct use of the valve in potentially explosive environments.

Coils assembled on these valves have been separately certified according to ATEX directive and so they are suitable for use in potentially explosive atmospheres.

1.1 - ATEX classification for valves

Type examination certificate: AR18ATEX055

The valves are suitable for applications and installations in potentially explosive atmospheres that fall within:

ATEX II 2G ATEX II 2D	*KD2	equipment intended for use in areas in which explosive atmospheres caused by gases, vapours, mists or air/dust mixtures are likely to occur occasionally. The means of protection relating to equipment in this category ensure the requisite level of protection, even in the event of frequently occurring disturbances or equipment faults which normally have to be taken into account.
ATEX I M2	*KDM2	equipment intended for use in underground parts of mines as well as those parts of surface installations of such mines likely to be endangered by firedamp and/or combustible dust. This equipment is intended to be de-energised in the event of an explosive atmosphere.

1.2 - ATEX marking for valves

valve code		N and V seals	NL seals
*KD2	for gas	II 2G IIC T4 Gb (-20°C Ta +80°C)	II 2G IIC T4 Gb (-40°C Ta +80°C)
	for dusts	II 2D IIIC T154°C Db IP66/IP68 (-20°C Ta +80°C)	II 2D IIIC T154°C Db IP66/IP68 (-40°C Ta +80°C)
*KD2 /T5	for gas	II 2G IIC T5 Gb (-20°C Ta +55°C)	II 2G IIC T5 Gb (-40°C Ta +55°C)
	for dusts	II 2D IIIC T129°C Db IP66/IP68 (-20°C Ta +55°C)	II 2D IIIC T129°C Db IP66/IP68 (-40°C Ta +55°C)
*KDM2	mining	I M2 I T150°C Mb IP66/68 (-20°C Ta +75°C)	I M2 I T150°C Mb IP66/68 (-40°C Ta +75°C)

Specific marking as ATEX 2014/34/EU directive and related technical specifications

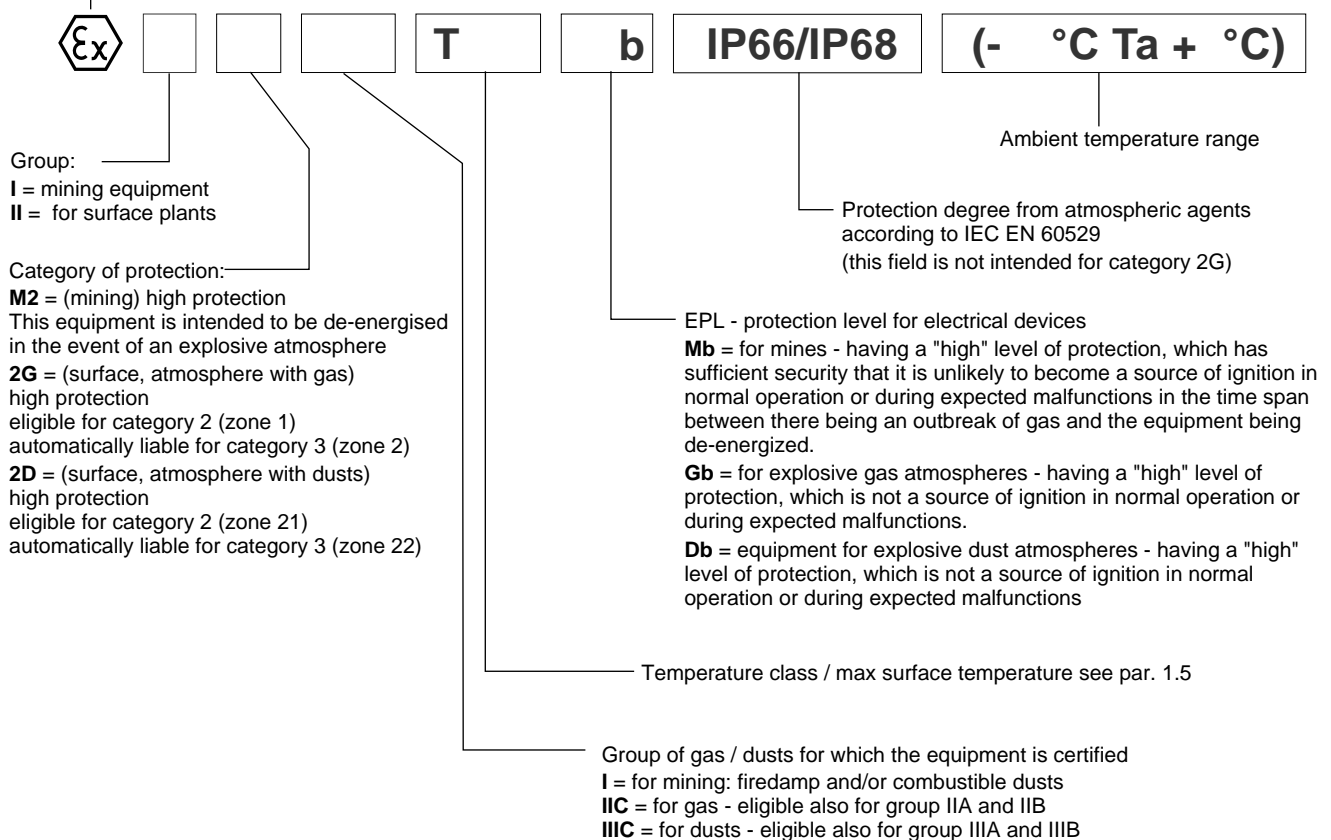







1.3 - ATEX classification of the coils

The coil of the explosion-proof valves is ATEX certified itself and, as such, is identified with its own tag, carries the relative ATEX marking. The mechanical construction of the coil housing is made in order to ensure its resistance to possible internal explosion and to avoid any explosion propagation to the outside environment, matching an "Ex db" type protection (explosion-proof coil).

Moreover, the solenoid is designed to maintain its surface temperature below the limits specified to the relevant class.

1.4 - ATEX marking on coils

for valve type *KD2	for gas for dusts	 II 2G Ex db IIC T4 Gb (-40°C Ta +80°C)  II 2D Ex tb IIIC T154°C Db IP66/IP68 (-40°C Ta +80°C)
for valve type *KD2 /T5	for gas for dusts	 II 2G Ex db IIC T5 Gb (-40°C Ta +55°C)  II 2D Ex tb IIIC T129°C Db IP66/IP68 (-40°C Ta +55°C)
for valve type *KDM2	mining	 I M2 Ex db I T150°C Mb IP66/IP68 (-40°C Ta +75°C)

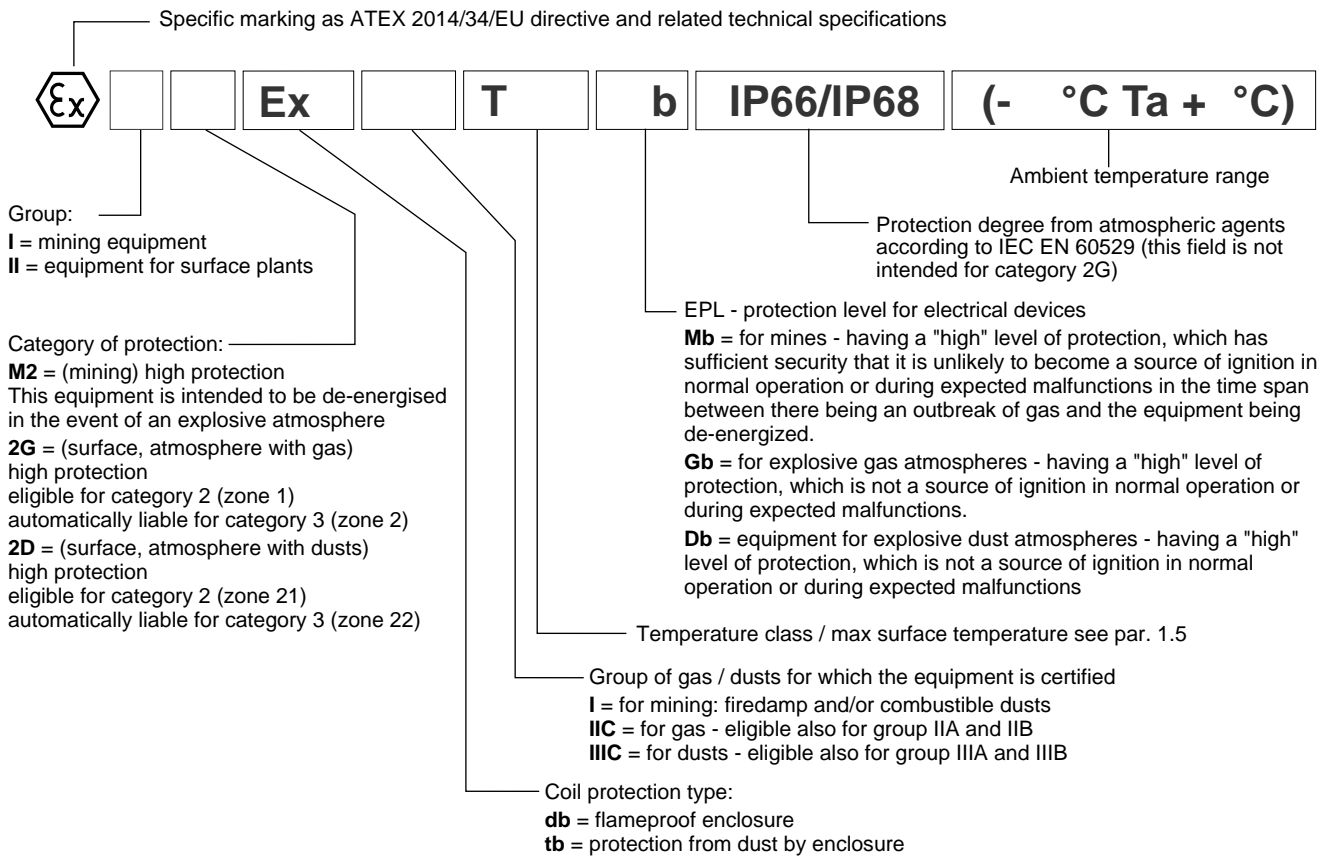

1.5 - Operating temperatures

These valves are classified according to their maximum surface temperature (EN 13463-1), which must be lower than the ignition temperature of the gases, vapors and dusts for which the area in which they will be used is classified.

The valves in group II can also be used for less limiting temperature classes (surface temperature allowed higher).

		temperature range	N and V seals	NL seals	Temperature class	eligible also for
ATEX II 2G ATEX II 2D	*KD2	of ambient	-20 / +80 °C	-40 / +80 °C	T4 (gas)	T3, T2, T1
		of fluid			T154°C (dusts)	T200°C and higher
	*KD2 /T5	of ambient	-20 / +55 °C	-40 / +55 °C	T5 (gas)	T4, T3, T2, T1
		of fluid	-20 / +60 °C	-40 / +60 °C	T129°C (dusts)	T135°C and higher
ATEX I M2	*KDM2	of ambient	-20 / +75 °C	-40 / +75 °C	T150°C	-
		of fluid				



2 - IECEX CLASSIFICATION AND TEMPERATURES

The IECEX certification requires the classification of the electrical equipment only.

Diplomatic supplies valves with IECEX certified coils, suitable for application and installation in potentially explosive atmospheres. The mechanical construction of the coil housing is made in order to ensure its resistance to possible internal explosion and to avoid any explosion propagation to the outside environment, matching an "Ex db" type protection (explosion-proof coil).

Moreover, the solenoid is designed to maintain its surface temperature below the limits specified to the relevant class.

The supply always includes the operating and maintenance manual, that contains all the information needed for a correct use of the valve in potentially explosive environment.

2.1 - IECEX classification

Certificate of conformity (CoC): IECEX TUN 15.0028X

The valves are suitable for applications and installations in potentially explosive atmospheres that fall within:

IECEX Gb IECEX Db	*KXD2	equipment intended for use in areas in which explosive atmospheres caused by gases, vapours, mists or air/dust mixtures are likely to occur occasionally. The means of protection relating to equipment in this category ensure the requisite level of protection, even in the event of frequently occurring disturbances or equipment faults which normally have to be taken into account.
IECEX Mb	*KXDM2	equipment intended for use in underground parts of mines as well as those parts of surface installations of such mines likely to be endangered by firedamp and/or combustible dust. This equipment is intended to be de-energised in the event of an explosive atmosphere.

2.2 - IECEX marking

There is a plate with the IECEX mark on each coil.

*KXD2 valves	for gas	Ex db IIC T4 Gb (-40°C Ta +80°C)
	for dusts	Ex tb IIIC T135°C Db (-40°C Ta +80°C)
*KXD2 /T5 valves	for gas	Ex db IIC T5 Gb (-40°C Ta +55°C)
	for dusts	Ex tb IIIC T100°C Db (-40°C Ta +55°C)
*KDM2 valves	mining	Ex db I Mb (-40°C Ta +80°C)

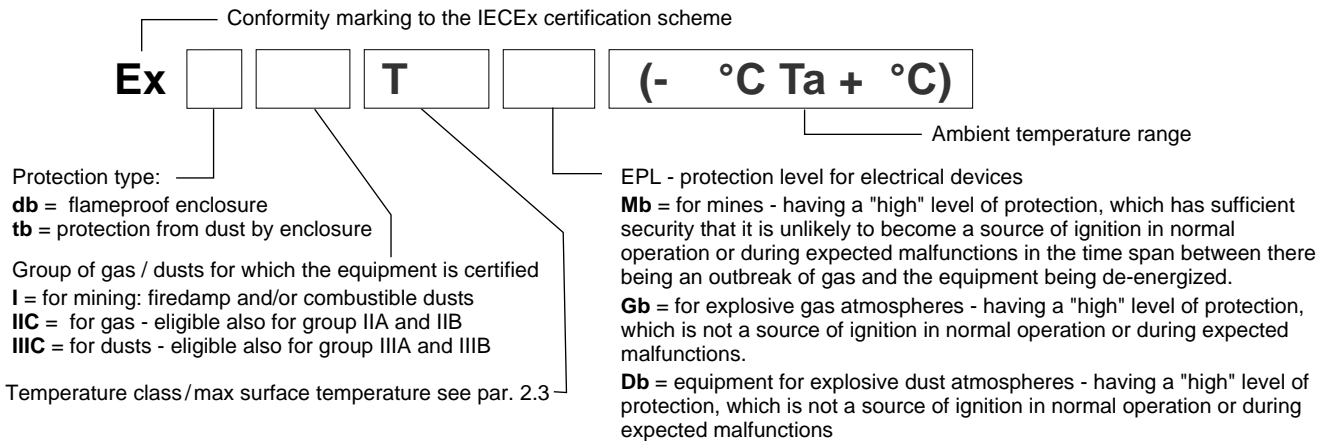

2.3 - Operating temperatures

These valves are classified according to their maximum surface temperature (EN 13463-1), which must be lower than the ignition temperature of the gases, vapors and dusts for which the area in which they will be used is classified.

Valves for surface plants can also be used for less limiting temperature classes (higher surface temperature allowed).

		temperature range	N and V seals	NL seals	Temperature class	eligible also for
IECEX Gb IECEX Db	*KXD2	of ambient	-20 / +80 °C	-40 / +80 °C	T4 (gas) T135°C (dusts)	T3, T2, T1 T200°C and higher
		of fluid				
IECEX Db	*KXD2 /T5	of ambient	-20 / +55 °C	-40 / +55 °C	T5 (gas) T100°C (dusts)	T4, T3, T2, T1 T135°C and higher
		of fluid				
IECEX Mb	*KXDM2	of ambient	-20 / +80 °C	-40 / +80 °C	-	-
		of fluid				

2.4 - Protection degree from atmospheric agents (IEC EN 60529)

Protection degree from atmospheric agents according to IEC EN 60529 is IP66/IP68.



3 - PESO CLASSIFICATION AND TEMPERATURES

The PESO certification requires the classification of the electrical equipment only.

Diplomatic supplies valves with PESO certified coils, suitable for application and installation in potentially explosive atmospheres. The mechanical construction of the coil housing is made in order to ensure its resistance to possible internal explosion and to avoid any explosion propagation to the outside environment, matching an “Ex db” type protection (explosion-proof coil).

Moreover, the solenoid is designed to maintain its surface temperature below the limits specified to the relevant class.

The supply always includes the operating and maintenance manual, that contains all the information needed for a correct use of the valve in potentially explosive environment.

3.1 - PESO classification

Certificate of conformity: P480801

The valves are suitable for applications and installations in potentially explosive atmospheres that fall within:

PESO Gb	*KPD2	equipment intended for use in areas in which explosive atmospheres caused by gases, vapours, mists are likely to occur occasionally. The means of protection relating to equipment in this category ensure the requisite level of protection, even in the event of frequently occurring disturbances or equipment faults which normally have to be taken into account.
---------	--------------	--

3.2 - PESO marking

There is a plate with the PESO mark on each coil.

*KPD2 valves	for gas	Ex db IIC T4 Gb (-40°C Ta +80°C)
*KPD2 /T5 valves	for gas	Ex db IIC T5 Gb (-40°C Ta +55°C)

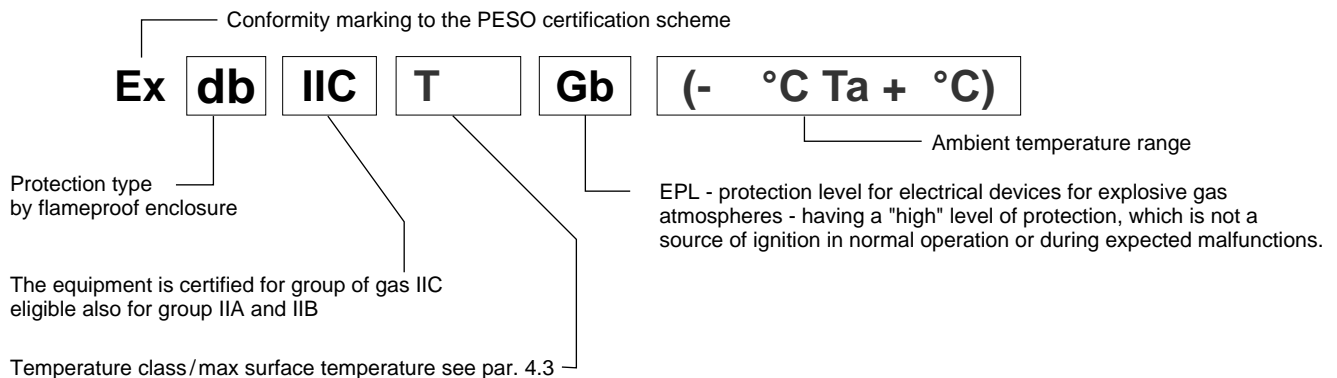

3.3 - Operating temperatures

These valves are classified according to their maximum surface temperature (EN 13463-1), which must be lower than the ignition temperature of the gases, vapors and dusts for which the area in which they will be used is classified.

Valves for surface plants can also be used for less limiting temperature classes (higher surface temperature allowed).

		temperature range	N and V seals	NL seals	Temperature class	eligible also for
PESO Gb	*KPD2	of ambient	-20 / +80 °C	-40 / +80 °C	T4 (gas)	T3, T2, T1
		of fluid				
	*KPD2 /T5	of ambient	-20 / +55 °C	-40 / +55 °C	T5 (gas)	T4, T3, T2, T1
		of fluid	-20 / +60 °C	-40 / +60 °C		

3.4 - Protection degree from atmospheric agents (IEC EN 60529)

Protection degree from atmospheric agents according to IEC EN 60529 is IP66/IP68.



DUPLOMATIC
MOTION SOLUTIONS
*a member of **DAIKIN** group*

DUPLOMATIC MS Spa

via Mario Re Depaolini, 24 | 20015 Parabiago (MI) | Italy
T +39 0331 895111 | E vendite.ita@duplomatic.com | sales.exp@duplomatic.com
duplomaticmotionsolutions.com