

# DXJ3

## DIRECT DRIVE SERVOVALVE WITH INTEGRATED ELECTRONICS SERIES 20



### SUBPLATE MOUNTING ISO 4401-03

**p** max **350** bar

**Q** max see performance table

### MOUNTING INTERFACE

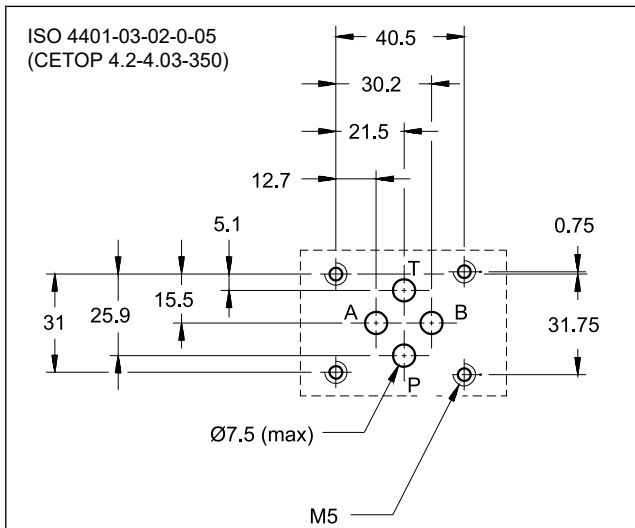

### OPERATING PRINCIPLE

- The DXJ3 valve is a four-port direct drive servo valve with integrated electronics. Its rotary-linear motor ensures high dynamic performance independent of system pressure.
- The advanced design minimises the overall dimensions without affecting the flow rate of the valve.
- DXJ3 valves are available in four flow rate control ranges up to 40 l/min, zero overlap spool and a mounting surface compliant with the ISO 4401-03 standards.
- They are suitable for control applications with closed loop of position, velocity and pressure.
- In case of power loss or missing enable signal, the spool moves towards the center position. For applications requiring a safety function, an external cut-off solenoid valve must be installed.

### PERFORMANCES

(with mineral oil of viscosity 32 cSt at 40 °C)

Maximum operating pressure Ports P - A - B Port T	bar	350 250
Rated flow Q nom (with $\Delta p$ 70 bar P - T)	l/min	5 - 10 - 20 - 40
Hysteresis	%	< 0.2
Threshold	%	< 0.05
Thermal drift (with $\Delta T = 40$ °C)	%	< 1%
Response time (0 to 100%)	ms	$\leq 12$
Vibration on all axes	g	30
Ambient temperature range	°C	-20 / +60
Power consumption	W	< 5
Fluid temperature range	°C	-20 / +80
Fluid viscosity range	cSt	5 ÷ 500
Fluid contamination degree	according to ISO 4406:1999 class 18/16/13	
Recommended viscosity	cSt	25
Mass	kg	1

### HYDRAULIC SYMBOL

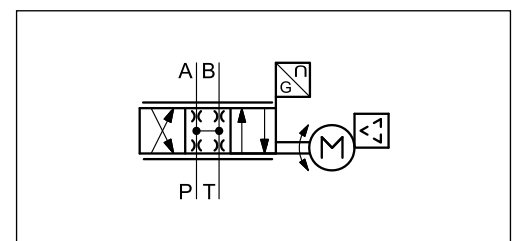

## 1 - IDENTIFICATION CODE

	<b>D</b>	<b>X</b>	<b>J</b>	<b>3</b>	<b>-</b>	<b>D</b>	<b>0</b>	<b>L</b>	<b>/</b>	<b>20</b>	<b>/</b>	<b>K11</b>	
--	----------	----------	----------	----------	----------	----------	----------	----------	----------	-----------	----------	------------	--

Direct drive servoproportional valve

Integrated electronics and position feedback

Mounting pattern ISO 4401-03

Symmetric spool

Spool lap  
**0** = zero overlap (1% linearized)  
 Others spool laps upon request.

Linear flow rate curve

Pin C function:  
**A** = external enable  
**C** = 0V monitor

6 pin + PE connection

Reference signal:  
**E0** = voltage  $\pm 10V$   
**E1** = current  $4 \div 20$  mA  
**E2** = current  $\pm 20$  mA

Seals:  
**N** = NBR seals for mineral oil (**standard**)  
**V** = FPM seals for special fluids

Series No. (from 20 to 29 size and mounting pattern do not change)

Rated flow (with p = 70 bar P - T)

<b>05</b> = 5 l/min	<b>20</b> = 20 l/min
<b>10</b> = 10 l/min	<b>40</b> = 40 l/min

### 1.1 - Available versions

**POWER OFF POSITION**

When a power failure occurs, the spool moves towards the center position, but the position is not determined.

For applications requiring a safety function, an external cut-off solenoid valve must be installed.

	<b>leakage flow</b> according to ISO 10770-1 at 100 bar [l/min]
rated flow	center position
<b>05</b>	< 0,1
<b>10</b>	< 0,3
<b>20</b>	< 0,5
<b>40</b>	< 0,5

### 2 - ELECTRONICS DATA

Duty cycle			100% (continuous operation)
Protection class according to IEC EN 60529			IP65 ( <b>NOTE 1</b> )
Supply voltage		V DC	24 (22 to 30 V DC)
Power consumption:	max typical	A	5 >1
Fuse protection, external		A	(timed), max current 5A
Command signal:	voltage (E0) current (E1) current (E2)	V DC mA mA	±10 (Impedance Ri = 200 kohm) 4 ÷ 20 (Impedance Ri = 392 ohm) ( <b>NOTE 2</b> ) ±20 (Impedance Ri = 392 ohm) ( <b>NOTE 3</b> )
Output signal:	voltage (E0) current (E1) current (E2)	V DC mA mA	±10 (Impedance Ro > 750 ohm) 4 ÷ 20 (Impedance Ro < 650 ohm) ( <b>NOTE 3</b> ) ±20 (Impedance Ro < 650 ohm)
Enabling / disabling (Pin C function = A) ( <b>NOTE 4</b> ): min / max voltage for drive enable min / max voltage for drive disable		V DC	9 / 28 (Impedance Ri >10 kohm) 0 / 4 (Impedance Ri >10 kohm)
Connection			6 pin + PE (MIL-C-5015-G - DIN EN 175201-804)
Electromagnetic compatibility (EMC) emissions EN55011:1998+A1 immunity EN 61000-6-2			According to 2014/30/EU standards

**NOTE 1:** The IP degree is guaranteed only with mating connector of equivalent IP degree, installed and tightened correctly.

**NOTE 2:** Valves with a current command signal (E1, E2 versions) use a 0.1% tolerance shunt resistor to measure demand current.

**NOTE 3:** The value of the shunt resistor to measure output current should not exceed stated maximum value.

**NOTE 4:** This function is available only for codes ending with K11A. Valves with a code E1 command type can also be enabled or disabled using the command signal; see the corresponding table at point 2.2 for further details.

#### 2.1 - Version with voltage command (E0)

The reference signal must be between -10 V and +10 V.

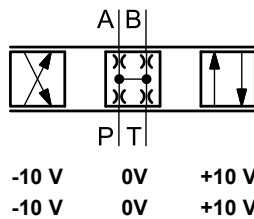

**COMMAND  
MONITOR**

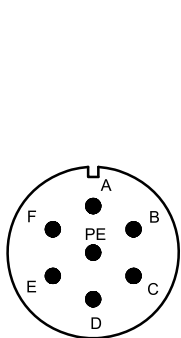

Pin	Values	A version	C version
A	24 V DC	Supply Voltage	
B	0V		
C		Enable see table in point 2	PIN F reference 0 V
D	± 10V	Command (differential input)	
E	0V	Command reference	
F	± 10V	Monitor signal ( <b>NOTE 5</b> )	
PE	GND	Ground (Earth)	

**NOTE 5:** The monitor signal is unaffected by variations resulting from null shift adjustment via the adjustment screw.

### 2.2 - Versions with current command (E1)

The reference signal is supplied in current  $4 \div 20$  mA. A current value in the range  $-20 \div 2$  mA will disable the motor drive until a current inside the range  $4 \div 20$  mA is received at the command input.

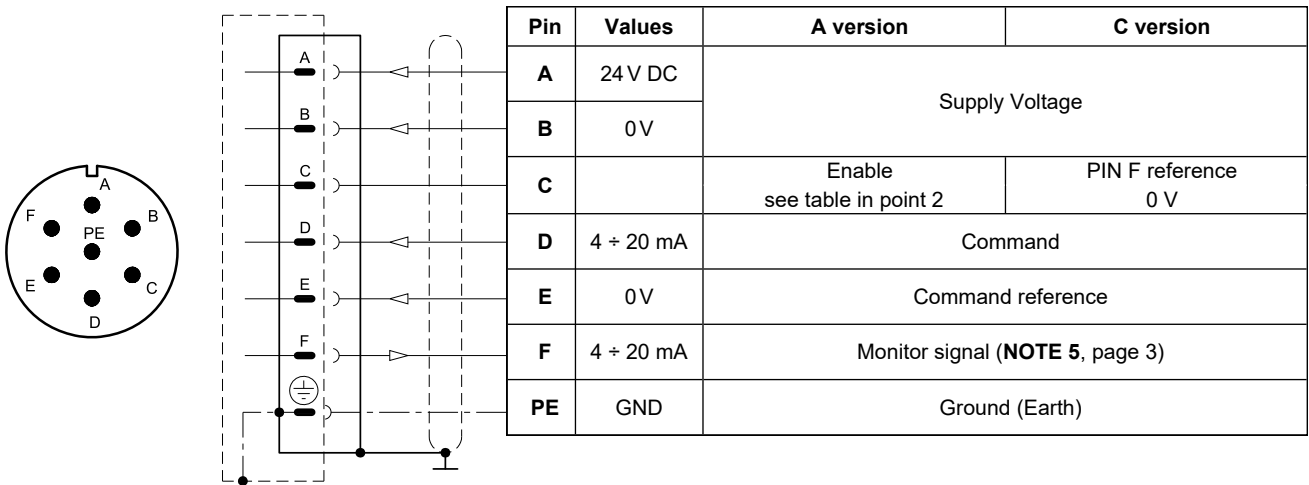

### 2.3 - Versions with current command (E2)

The reference signal is supplied in current  $-20 \div 20$  mA.

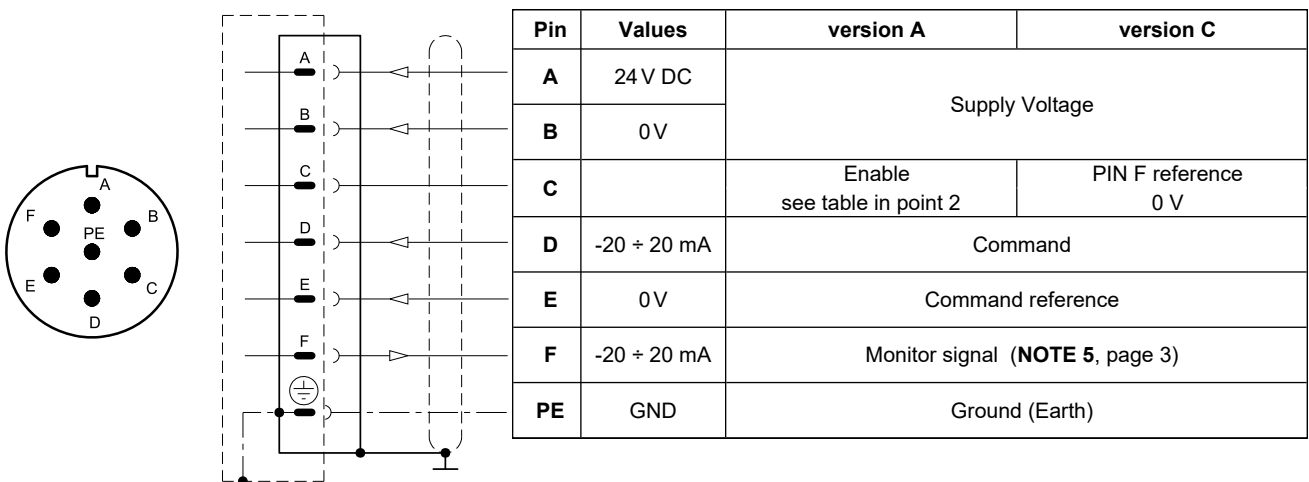

### 3 - CHARACTERISTIC CURVES

(measured with viscosity of 36 cSt at 50 °C)

REFERENCE / FLOW RATE CURVE

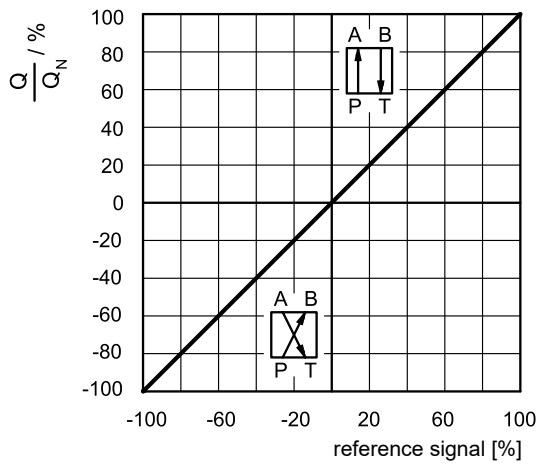

FLOW RATE CURVE ACCORDING TO  $\Delta p$

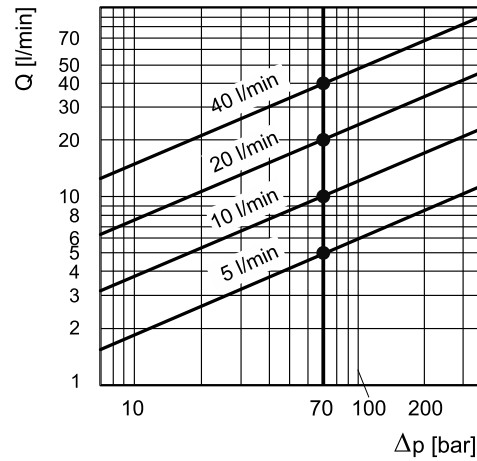

Typical flow rate curves at constant  $\Delta p = 70$  bar P-T according to the reference signal.

**NOTE:** with positive reference signal connected to pin D the valve regulates P - A / B - T.

The diagram states the maximum valve controlled flow rate according to the pressure drop between the P and T ports.

PRESSURE GAIN

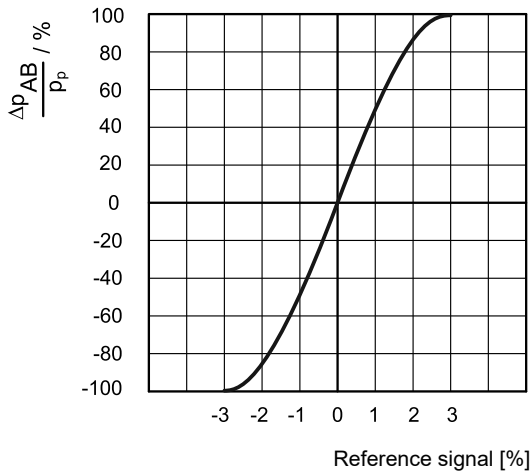

The diagram states the valve pressure gain, expressed as % of the ratio between the port pressure variation in A or B ( $\Delta p_{AB}$ ) and the P system pressure, according to the reference signal.

In practice, the pressure gain states the valve reaction to external disturbances aimed at changing the actuator position.

RESPONSE TIME

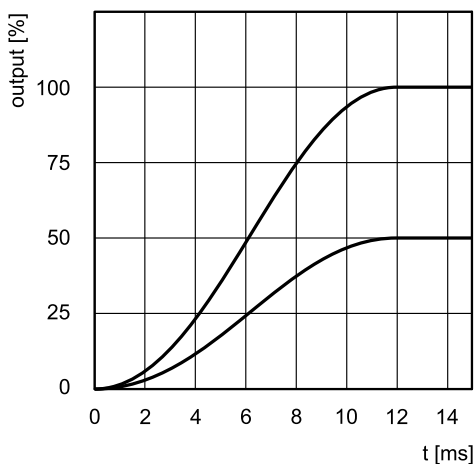

$\Delta p = 70$  bar

### FREQUENCY RESPONSE

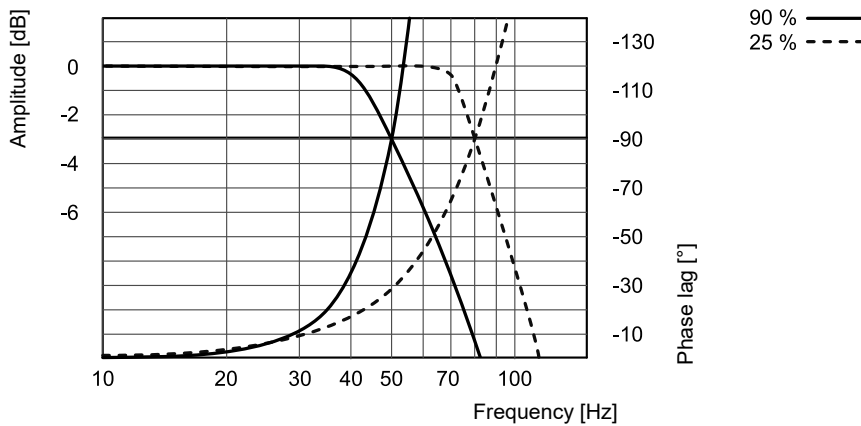

### 4 - DXJ3 - OVERALL AND MOUNTING DIMENSIONS

dimensions in mm

**NOTE:** The potentiometer's angular adjustment range is 270°; adjusting ±3% of the maximum flow.  
 Clockwise rotation to increase flow P→A  
 Counterclockwise rotation to increase flow P→B  
**(NOTE 5, page 3)**  
 Proceed with the adjustment gently. Excessive force may damage the potentiometer.

Fastening bolts: 4 SHC screws M5x60	
Torque: 7.5 Nm ± 10% (A10.9)	
Threads of mounting holes: M5x12	

1	Mounting surface with sealing rings: N. 4 OR type 2037 (9.25x1.78) 70 Shore
2	Main connection
3	Status LED: Solid green: valve okay, drive On Solid red: valve okay, drive Off Flashing red: fault
4	Null adjustment: 1.7 mm (0.067 in.) cross-slot tool.
5	Mating connector 6 poles + PE, female type MIL-5015-G To be ordered separately. See catalogue 89 000

### 5 - HYDRAULIC FLUIDS

Use mineral oil-based hydraulic fluids HL or HM type, according to ISO 6743-4. For these fluids, use NBR seals. For fluids HFDR type (phosphate esters) use FPM seals (code V). For the use of other kinds of fluid such as HFA, HFB, HFC, please consult our technical department.

Using fluids at temperatures higher than 80 °C causes a faster degradation of the fluid and of the seals characteristics.

The fluid must be preserved in its physical and chemical characteristics.

### 6 - INSTALLATION

The valves can be installed in any position without impairing correct operation. Valves are fixed by means of screws or tie rods on a flat surface with planarity and roughness equal to or better than those indicated in the relative symbols.

If minimum values are not observed, fluid can easily leak between the valve and support surface.

Take care to the cleanliness of the mounting surfaces and surrounding environment upon installation.

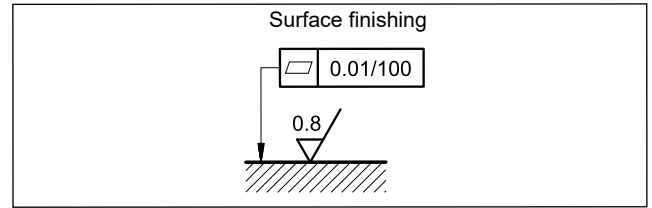

### 7 - ACCESSORIES

(to be ordered separately)

#### 7.1 - Mating connector

Mating connector must be ordered separately. See catalogue 89 000.



The use of a metal connector is recommended to avoid electromagnetic disturbances and to ensure compliance with EMC regulations on electromagnetic compatibility. If a plastic connector is used, it must guarantee and maintain the IP rating and the EMC protection characteristics of the valve.

Duplomatic offers spare parts to be wired and also ready-to-use cord sets. Please refer to cat. 89 000.

#### 7.2 - Connection cable

The optimal wiring provides for 7 isolated conductors, with separate screen for the signal wires (command, monitor) and an overall screen.

Cross section for power supply:

- up to 20 m cable length: 1.0 mm<sup>2</sup>
- up to 40 m cable length: 1.5 mm<sup>2</sup>

Cross section for signals (command, monitor):

- 0.50 mm<sup>2</sup>

### 8 - SUBPLATES

(see catalogue 51 000)

Type PMMD-AL3G ports on rear
Type PMMD-AL3G side ports
P, T, A, B port threading: 3/8" BSP



**DXJ3**  
SERIES 20

**DUPLOMATIC**  
MOTION SOLUTIONS  
*a member of **DAIKIN** group*

**DUPLOMATIC MS Spa**

via Mario Re Depaulini, 24 | 20015 Parabiago (MI) | Italy

T +39 0331 895111 | E vendite.ita@duplomatic.com | sales.exp@duplomatic.com  
duplomaticmotionsolutions.com