



# FPHM

## PRESSURE FILTER

### SERIES 10

#### MODULAR VERSION

**p** max **320** bar  
**Q** max (see table of performances)

#### OPERATING PRINCIPLE

- The FPHM filters are designed for modular mounting, directly under proportional valves or servovalves with ISO 4401 mounting interfaces.
- They are available in two nominal dimensions with mounting surface ISO 4401-03 and ISO 4401-05.
- These filters are designed for working pressures up to 320 bar. Filter elements are made of high efficiency filtering materials and they are available with three different filtration degrees, with a collapsing differential pressure of 210 bar:

F05 = 5  $\mu$ m absolute  
( $\beta_5 > 100$  - ISO 4406:1999 class 17/15/12)  
F10 = 10  $\mu$ m absolute  
( $\beta_{10} > 100$  - ISO 4406:1999 class 18/16/13)  
F25 = 25  $\mu$ m absolute  
( $\beta_{25} > 100$  - ISO 4406:1999 class 19/17/14)

- All the FPHM filters are supplied without by-pass valve.
- Filters are arranged for clogging indicator, which must be always ordered separately and mandatorily installed by the customer (see point 5).

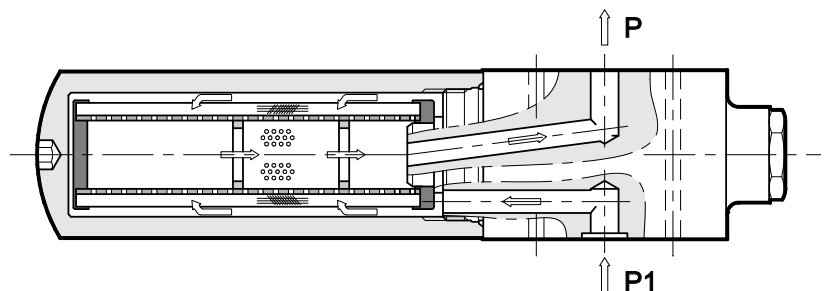

#### PERFORMANCES

Filter	Dimensions	Mass [kg]	Rated flow (indicative) [l/min]		
			F05	F10	F25
<b>FPHM3</b>	ISO 4401-03	2,6	12	13,5	16
<b>FPHM5</b>	ISO 4401-05	4,7	22	25	28

**NOTE 1:** Flow rates stated in the table correspond to a 3 bar pressure drop, measured with mineral oil of viscosity 36 cSt at 50°C.

As for a different viscosity range, see **NOTE 2 - p. 2.2.**

Maximum operating pressure	bar	320
Collapsing differential pressure of the filter element	bar	210
Ambient temperature range	°C	-25 / +50
Fluid temperature range	°C	-25 / +110
Fluid viscosity range	cSt	10 ÷ 400

#### HYDRAULIC SYMBOL

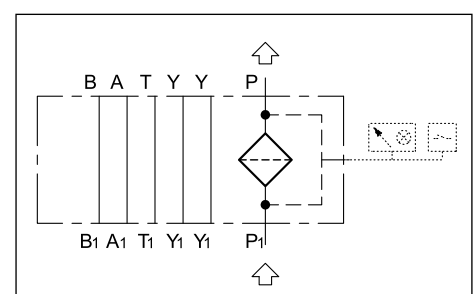

## 1 - IDENTIFICATION CODE

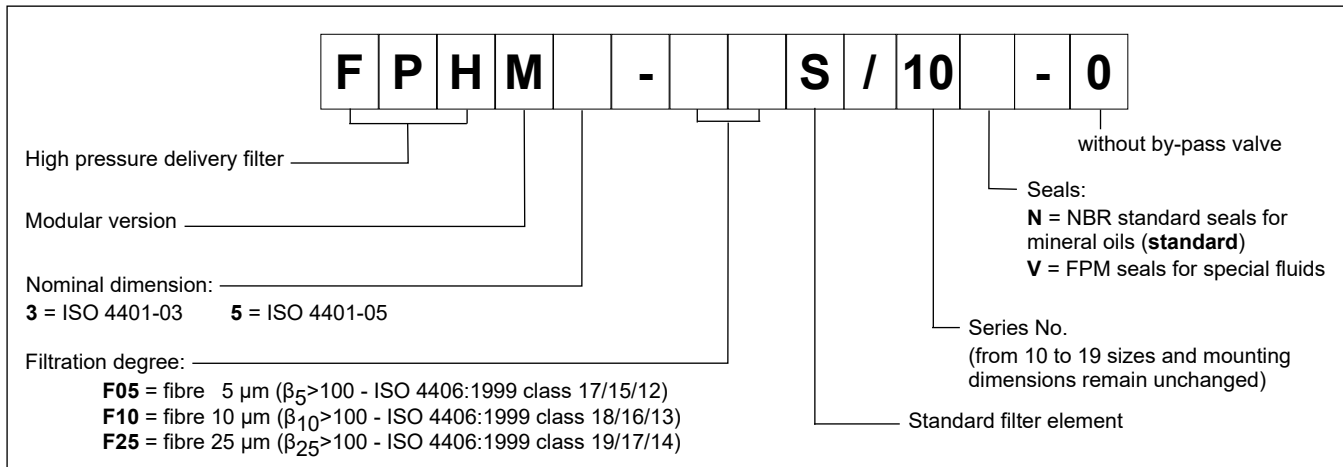

## 2 - CHARACTERISTIC CURVES

(values measured with viscosity of 36 cSt at 50°C)

### 2.1 - Pressure drops through the filter body

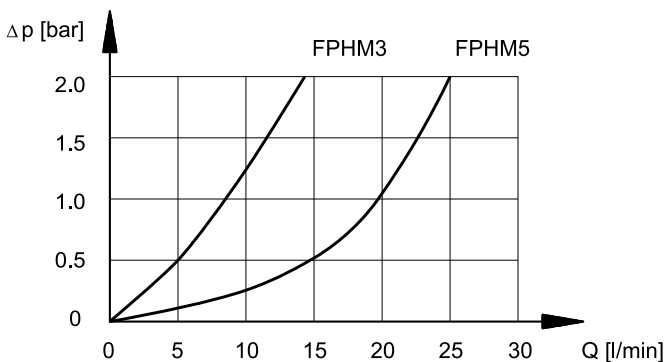

### 2.2 - Pressure drops through FPHME filter element

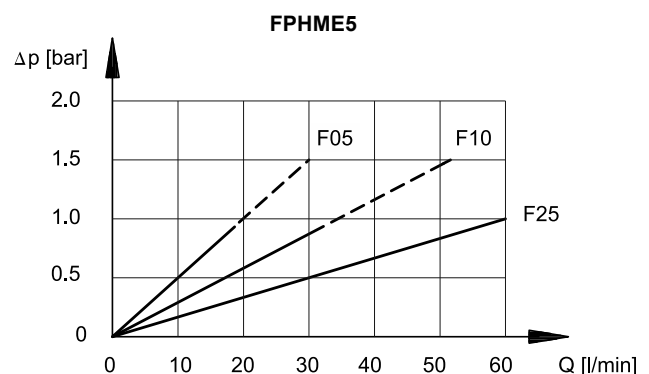
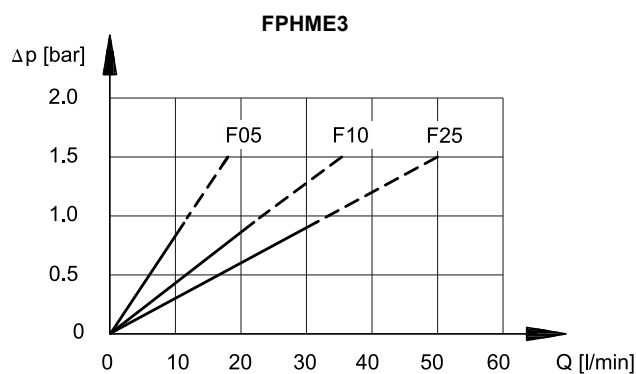

**NOTE 2: The filter size has to be selected so that with nominal flow rate, the total pressure drop is less than 1.2 bar.**

The total pressure drop through the filter is given by adding the body pressure drop values to those of the filter element. As for fluids whose viscosity degree at a specific operating pressure is different from 36 cSt, the filter total pressure drop has to be changed according to the following ratio:

$$\text{total } \Delta p \text{ value} = \text{body } \Delta p \text{ value} + (\text{real } \Delta p \text{ value of the filter element} \times \text{real viscosity value (cSt)} / 36)$$

$$\text{real } \Delta p \text{ value of the filter element} = \text{value obtainable through the diagrams in p. 2.2}$$

Such ratio is valid for a viscosity value up to 200 cSt. For a higher viscosity please consult our technical department.

### 3 - HYDRAULIC FLUIDS

Use mineral oil-based hydraulic fluids HL or HM type, according to ISO 6743-4. For these fluids, use NBR seals. For fluids HFDR type (phosphate esters) use FPM seals (code V). For the use of other kinds of fluid such as HFA, HFB, HFC, please consult our technical department. Using fluids at temperatures higher than 80 °C causes a faster degradation of the fluid and of the seals characteristics.

The fluid must be preserved in its physical and chemical characteristics.

### 4 - OVERALL AND MOUNTING DIMENSIONS

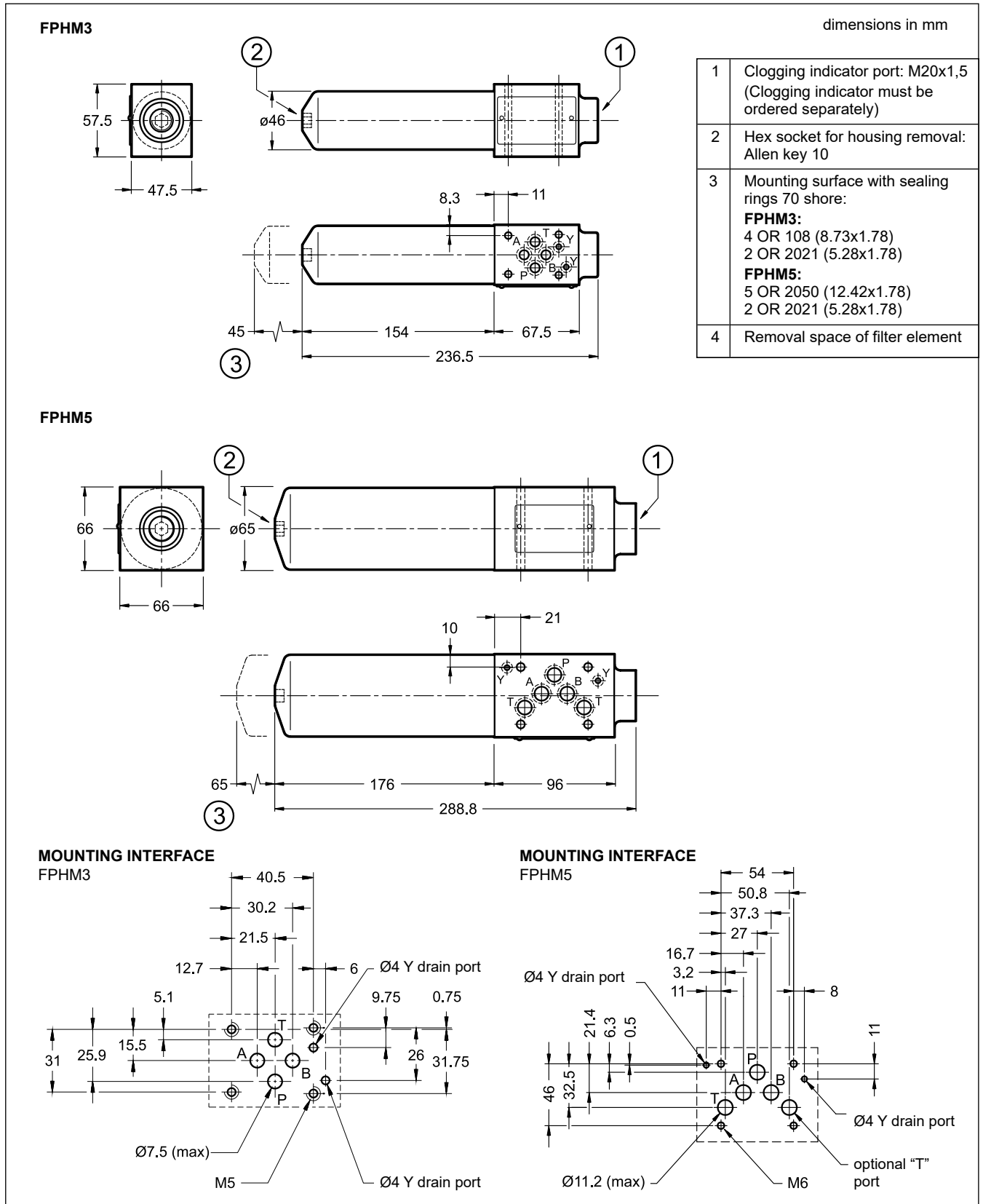

## 5 - CLOGGING INDICATORS

The filters are all designed to incorporate clogging indicators, which have to be ordered separately. Tightening torque 90 Nm

### 5.1 - Visual indicator for modular filters

Identification code: **VM/10**

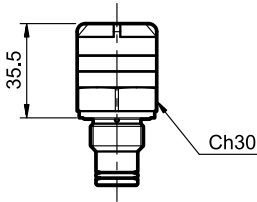

This indicator measures the differential pressure between the filter input and output.

The indicator is supplied with coloured bands, which informs you about the clogging condition of the filter element:

WHITE: efficient filter element  
 $\Delta p < 8 \text{ bar } (\pm 10\%)$

RED: the filter element has to be replaced  
 $\Delta p > 8 \text{ bar } (\pm 10\%)$

### 5.2 - Electric-visual indicator for modular filters

Identification code: **EM/10**

This type of indicator, in addition to giving a visual indication as the VM model, operates by switching an electric contact when the filter element has reached the clogging limit.

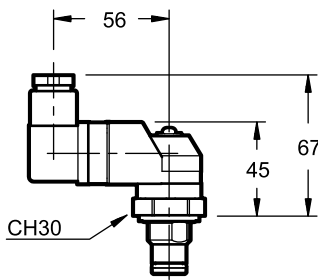

The contact can be wired in an open or closed condition (see scheme).

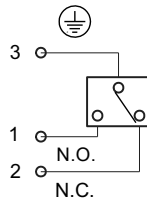

## TECHNICAL SPECIFICATIONS

		AC	DC
Differential operating pressure	bar	8	
Operating voltage	V	125 - 250	14 - 30
Max. load on contacts	A	1	4
		1	3
Electric connector	EN 175301-803 (ex DIN 43650)		
Class of protection according to EN 60529 (atmospheric agents)	IP65		

## 6 - FILTER ELEMENTS

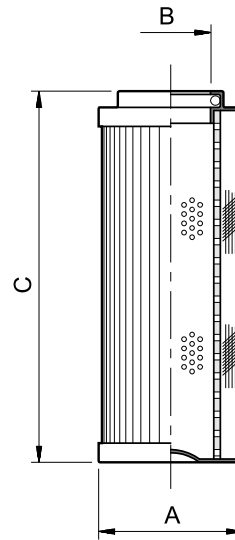

Filter element code	ØA	ØB	C	Average filtering surface [cm <sup>2</sup> ]
<b>FPHME3</b>	33	16	100	270
<b>FPHME5</b>	45	25	115	475

## FILTER ELEMENTS IDENTIFICATION CODE

**FPHME** - **S / 10**

Filter element for FPHM modular filter

Nominal dimension:  
**3** = ISO 4401-03  
**5** = ISO 4401-05

Filtration degree : **F05** = fibre 5 µm  
**F10** = fibre 10 µm  
**F25** = fibre 25 µm

Standard filter element

Series No.  
 (from 10 to 19 sizes and mounting dimensions remain unchanged)

**N** = NBR seals for mineral oils (**standard**)  
**V** = FPM seals for special fluids (upon request)