

# SUT

## HIGH PRECISION SUPER UNIT (HYBRID HYDRAULIC SERVO PUMP) SERIES 40

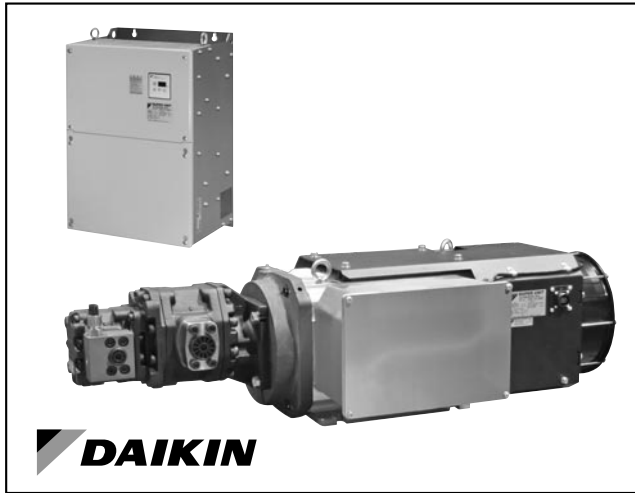

**MOTOR PUMP FLOW RATE**  
50 to 200 l/min

### DESCRIPTION

The high precision SUPER UNITS are designed and manufactured by Daikin Industries LTD.

The unit is made of the motor-pump and its controller, plus the pressure sensor, supplied with the pump.

A kit with the electrical accessories needed to wire the controller according to EC standards is offered separately. The kit also includes the cables for the pressure sensor and the encoder.

The SUT is designed for industrial machinery, such as presses and moulding machines.

This hybrid power unit achieves high torque and precision control with up to 1% hysteresis and linearity over the entire range of pressure/flow rate.

As an alternative to analogue command values for pressure and flow rate, the operation conditions can be selected easily by using 3-bit ON/OFF digital signals that can call eight different preset pressure/flow rate patterns (8-PQ type: settable using a parameter).

The flow is controlled during the cylinder operation. When the load pressure exceeds the pressure command, the rotation speed is reduced to control the pressure. The SUT allows bigger energy saving and more precise control of the machine, compared to conventional hydraulic control methods.

This technology leads to a real advantage for the machinery on which the SUT works in terms of oil and heat-sensitive parts lifetime, and less heat dissipation in the surrounding ambient.

On SUTs equipped with a double pump, the primary pump delivers high pressure and limited flow. When the flow rate request is higher than the flow rate that the primary pump can supply, the second pump is also activated guaranteeing the required flow, but lowering the pressure.

The switching from single to combined operation is done by a solenoid valve. This solenoid valve can be managed automatically by the SUT or can be activated by an external signal from the PLC.

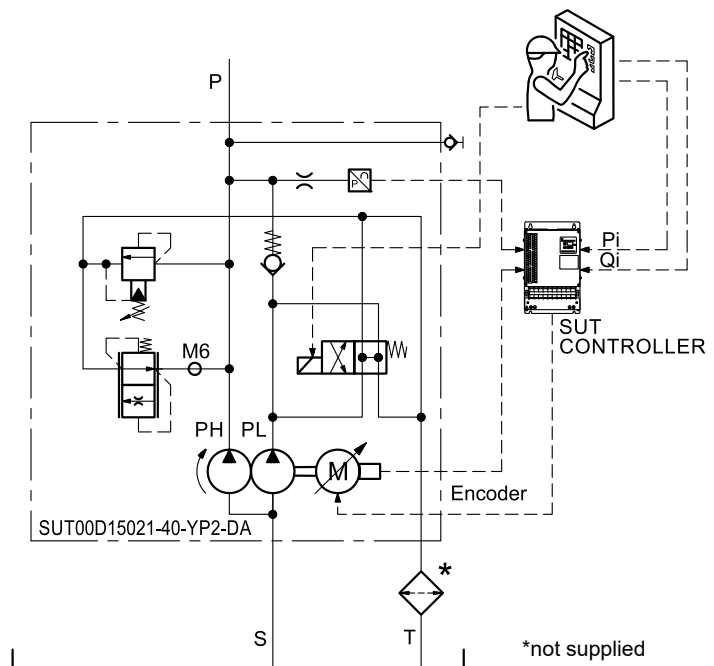

## 1 - IDENTIFICATION CODE

The delivery of codes below includes the motor pump controller.

Each controller is associated with its own motor pump and cannot be exchanged, even between machines of the same model, as the controller and the motor pump are tuned and tested as a unit.

### 1.1 - Single pump versions

<b>SUT00</b>	<b>S</b>		<b>-</b>	<b>40</b>	<b>Y</b>	<b>-</b>	<b>DA</b>
--------------	----------	--	----------	-----------	----------	----------	-----------

High Precision SUPER UNIT

Single pump

**5021** = max flow rate **50 l/min**; max op. pressure **210 bar**  
**10021** = max flow rate **100 l/min**; max op. pressure **210 bar**  
**13021** = max flow rate **130 l/min**; max op. pressure **210 bar**

Series No. \_\_\_\_\_  
 (from 40 to 49 sizes and mounting dimensions remain unchanged)

Suction port at bottom

**N** = Basic version, without manifold  
**P1** = With manifold for unloading

3-phase AC power supply  
 380/440 V 50/60 Hz  
 without transformer

### 1.2 - Double pump versions

<b>SUT00</b>	<b>D</b>		<b>-</b>	<b>40</b>	<b>Y</b>	<b>-</b>	<b>DA</b>
--------------	----------	--	----------	-----------	----------	----------	-----------

High precision SUPER UNIT

Double pump

**8021** = max flow rate **80 l/min**; max op. pressure **210 bar**  
**15021** = max flow rate **150 l/min**; max op. pressure **210 bar**  
**20025** = max flow rate **200 l/min**; max op. pressure **250 bar**

Series No. \_\_\_\_\_  
 (from 40 to 49 sizes and mounting dimensions remain unchanged)

Suction port at bottom

**N** = basic version, without manifold  
**P2** = with manifold for pressure selection and unloading (not available for SUT00D20025)

3-phase AC power supply  
 380/440 V 50/60 Hz  
 without transformer

**NOTE:** The suction flange for SUT00D20025-40YN-DA is a customized part. It must be ordered separately. See details and ordering code in p. 9.4.

**2 - SPECIFICATIONS**

		SUT00S*			SUT00D*		
		5021	10021	13021	8021	15021	20025
Maximum operating pressure	bar	206			206		250
Operating pressure range: - 1 <sup>st</sup> pump (HP) - 1 <sup>st</sup> + 2 <sup>nd</sup> pump (HP+LP)	bar	2.1 ÷ 206 -			2.1 ÷ 206 2.1 ÷ 176		2.5 ÷ 250 2.5 ÷ 165
Operating flow range ( <b>NOTE 1</b> ): - 1 <sup>st</sup> pump (HP) - 1 <sup>st</sup> + 2 <sup>nd</sup> pump (HP+LP)	l/min	0.5 ÷ 50 -	1 ÷ 100 -	1.3 ÷ 130 -	0.8 ÷ 38.4 0.8 ÷ 80	1.5 ÷ 70.9 1.5 ÷ 150	2 ÷ 56 2 ÷ 200
Pump type		gear pump			double gear pump		
Pump displacement: - 1 <sup>st</sup> pump (HP) - 1 <sup>st</sup> + 2 <sup>nd</sup> pump (HP+LP)	cm <sup>3</sup>	20.7 -	38.6 -	44 -	15 31.2	24.9 52.7	20.8 74.1
Controller input power ( <b>NOTE 2</b> )		3-phase AC 380 V to 440 V 50/60 Hz					
Permissible voltage fluctuation		-15% to +10%			-20% to +10%		
Required power supply capacity	kVA	20.1	34.8	34.8	20.1	34.8	52
Recommended breaker capacity	A	30	40	40	30	40	50
Nominal motor power	kW	11	15	15	11	15	22
Motor rated input current	A	21	29	29	21	29	45
Leak current ( <b>NOTE 4</b> )	mA	2.1	3.9	3.9	2.1	3.9	2.8
Motor cooling fan power		1-phase AC 200 to 240 V 50/60 Hz					
Pump switching valve power		-	-	-	DC 24 V ±10% - ( <b>NOTE 3</b> )		
Ambient temperature range	°C	motor pump 0 to +40; controller 0 to +55 (no freezing)					
Fluid temperature range	°C	0 to +60 (recommended +15 to +50)					
Fluid contamination degree		ISO 4406:1999 class 20/18/15					
Viscosity		Viscosity grade: ISO VG32 to 68 • Viscosity range: 15 to 400 mm <sup>2</sup> /s					
Operating ambient humidity	RH	< 85%, without condensation					
Protection class		motor pump IP44 ( <b>NOTE 5</b> ); controller IP00 (IP54 cabinet needed)					
Vibration resistance: - Motor pump - Controller		30.0 m/s <sup>2</sup> 33.3 Hz, 3 directions, X/Y: 2 Hr Z: 4 Hr 21.6 m/s <sup>2</sup> 33.3 Hz, 3 directions, X/Y: 2 Hr Z: 4 Hr					
Installation		Altitude max 1000 m, indoor. Motor pump: horizontally on the base for the hydraulic unit Controller: inside cooled electrical cabinet IP54, vertical position					
Communication port		RS232C					
Mass: - motor pump without manifold - motor pump with manifold - controller	kg	59 61.8 10	89 94.5 10.4	89 94.5 10.4	61 71 10	89 99 10.4	115 - 14

**NOTE 1:** The maximum flow rate is the theoretical flow rate and is not guaranteed.

**NOTE 2:** Even if the unit is used within the permissible power voltage fluctuation range, the p/Q output characteristics may deteriorate if undervoltage occurs. Also note that overvoltage fluctuation may cause alarms, due to overloading of regenerative operation, depending on the operation conditions. You are therefore recommended to use the unit in an environment with limited power voltage fluctuation as far as possible.

**NOTE 3:** For models without delivery manifold (codes ending with N-DA), the Customer must arrange the discharge manifold with switching valve, or provide a flow rate selection mechanism in the hydraulic circuit.

**NOTE 4:** Representative values when using the recommended noise filter. Protection against noise, in accordance with Daikin recommendations, may be required depending on the operating environment.

**NOTE 5:** The shaft through hole, encoder connector, motor cooling fan and terminal block are excluded.

### 3 - SUT00S5021 (11 KW MOTOR)

Values obtained and rated for ambient temperature  $\leq 40\text{ }^{\circ}\text{C}$  and fluid temperature  $\leq 60\text{ }^{\circ}\text{C}$ .

#### 3.1 - Continuous and Short-Time Operation Limits

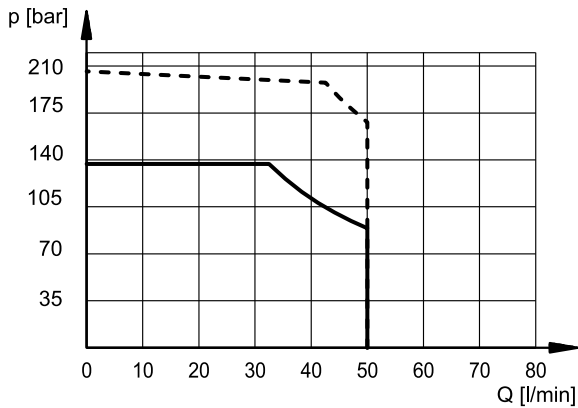

— continuous operation  
 - - - short-time operation ( $\leq 20\%$  of duty cycle time)

The unit is designed for continuous operation (S1) within the range specified in the characteristic chart. Operation may be extended up to 60 seconds within the short-time rating, provided it does not exceed 20% of the duty cycle.

#### 3.2 - p/Q command

The accuracy of both pressure and flow command is  $\leq 0.1\%$  within the entire working cycle.

The 0 V command corresponds to the minimum operating pressure/flow value as specified on page 3, Table 2.

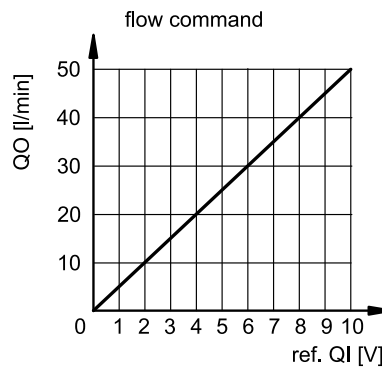
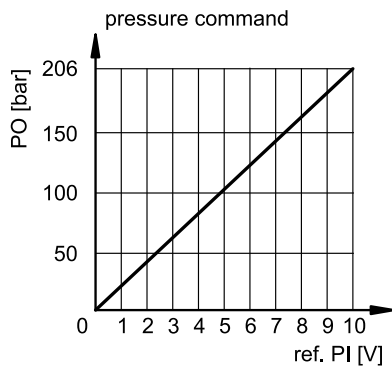

#### 3.3 - SUT00S5021-40YN-DA circuit diagram (basic version)

The customer is responsible for the discharge manifold of the motor pump. Reference example in point 4.7. The pressure sensor is supplied. For technical details, please refer to section 12.

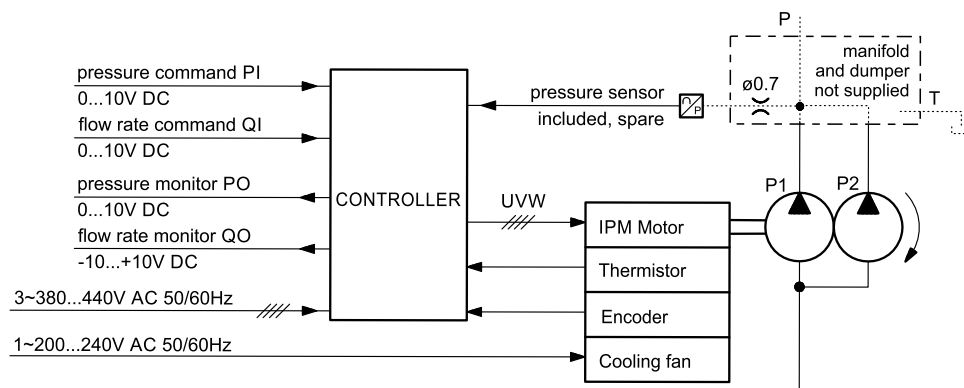

#### 3.4 - SUT00S5021-40YP1-DA circuit diagram (with manifold)

The manifold mounted on the motor pump is equipped with a pressure relief valve to protect the pump and the pressure sensor. See details at point 3.7.

See instructions for the pressure relief valve at point 7.4.

### 3.5 - SUT00S5021-40YN-DA overall dimensions (basic version)

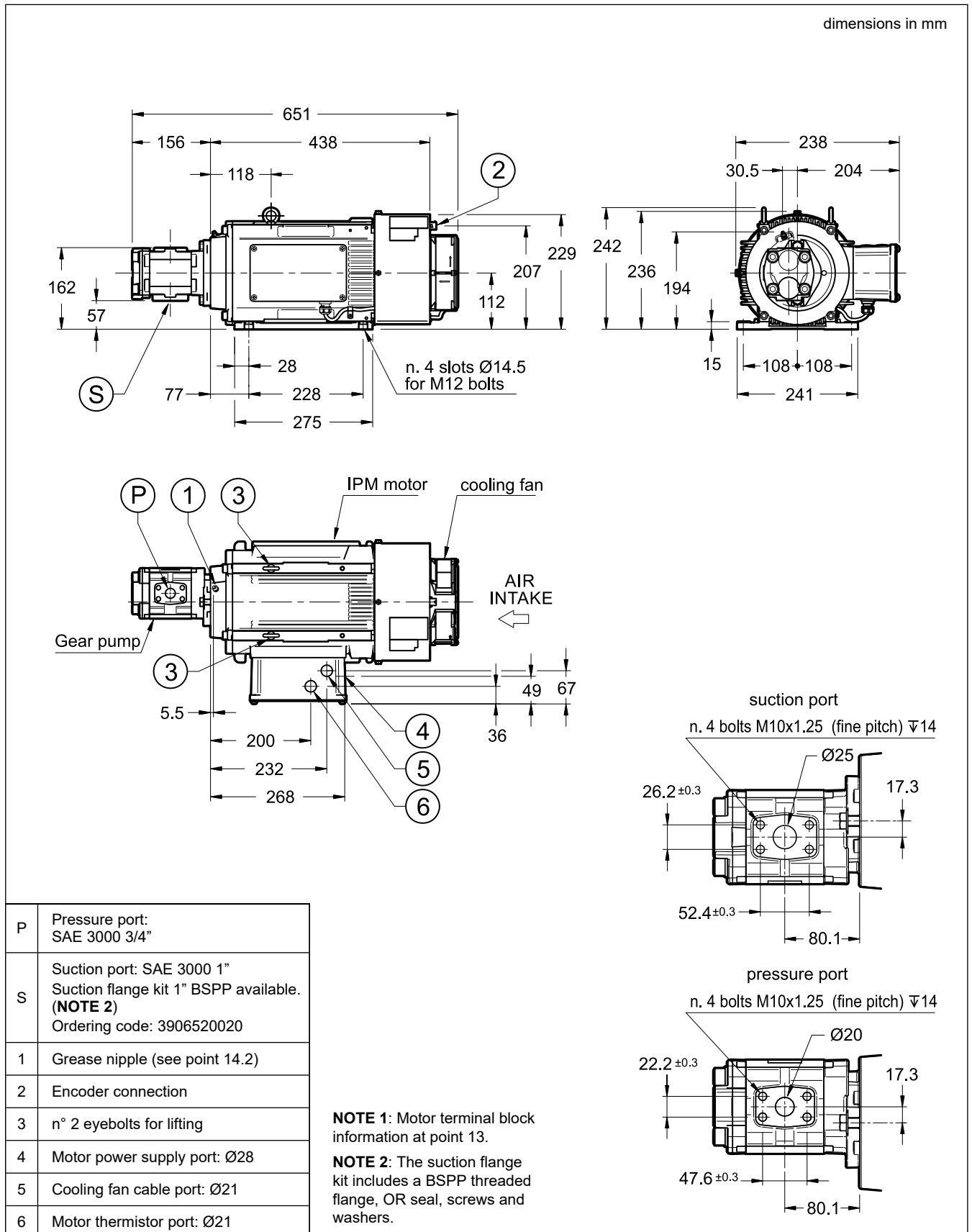

### 3.6 - Controller

Please refer to point 10 to find information relating to the controller for this motor pump.

### 3.7 - SUT00S5021-40YP1-DA overall dimensions (with manifold)

Please refer to the drawing of SUT00S5021-40YN-DA for missing dimensions.

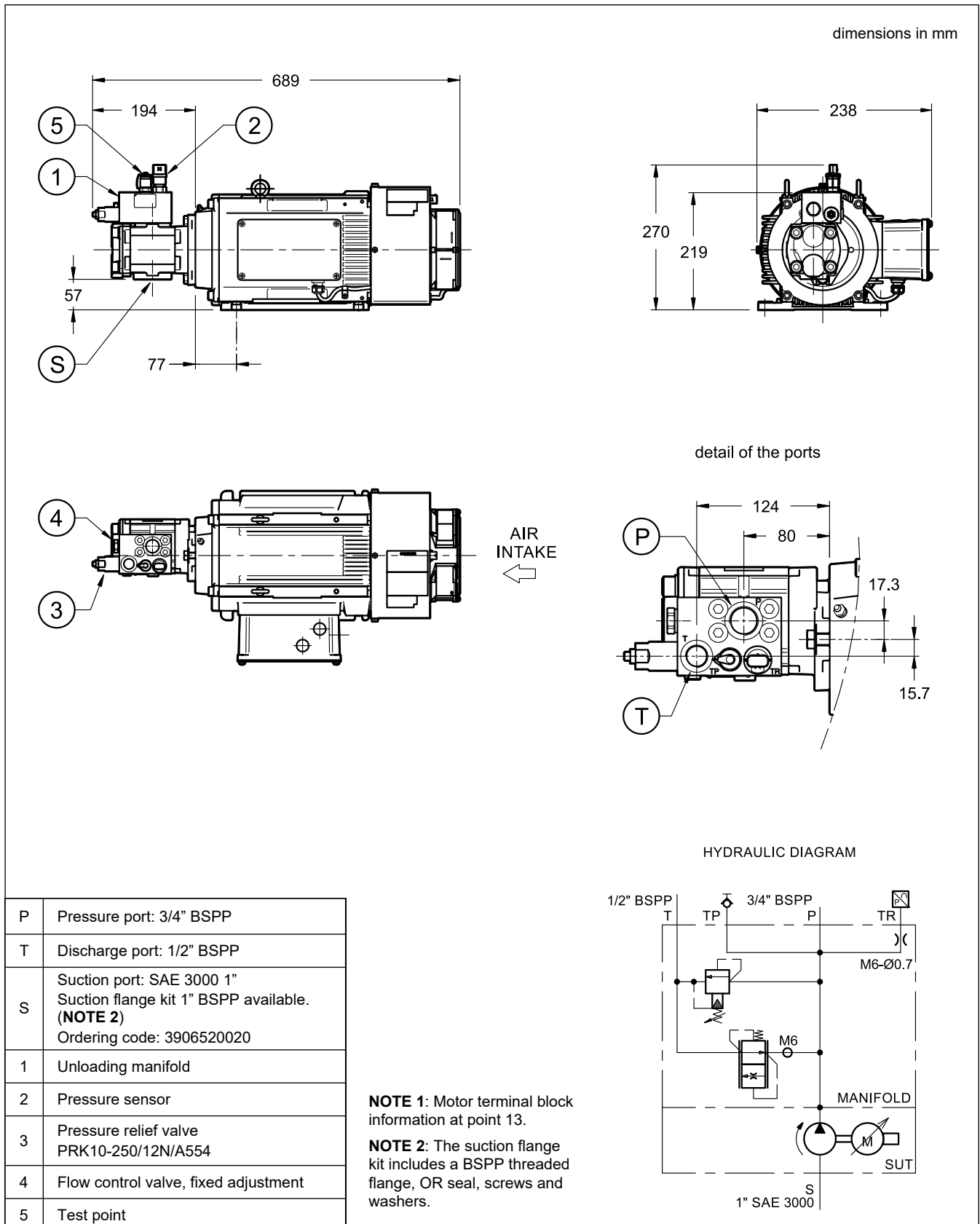

### 3.8 - Controller

Please refer to point 10 to find information related to the controller for this motor pump.

## 4 - SUT00S10021 (15 KW MOTOR)

Values obtained and rated for ambient temperature  $\leq 40\text{ }^{\circ}\text{C}$  and fluid temperature  $\leq 60\text{ }^{\circ}\text{C}$ .

### 4.1 - Continuous and Short-Time Operation Limits

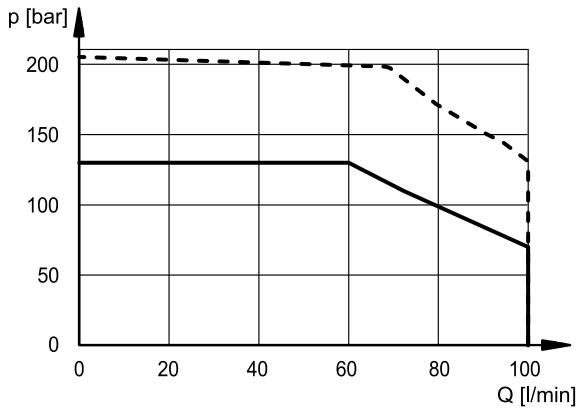

— continuous operation  
 - - - short-time operation ( $\leq 20\%$  of duty cycle time)

The unit is designed for continuous operation (S1) within the range specified in the characteristic chart. Operation may be extended up to 60 seconds within the short-time rating, provided it does not exceed 20% of the duty cycle.

### 4.2 - p/Q command

The accuracy of both pressure and flow command is  $\leq 0.1\%$  within the entire working cycle.

The 0 V command corresponds to the minimum operating pressure/flow value as specified on page 3, Table 2.

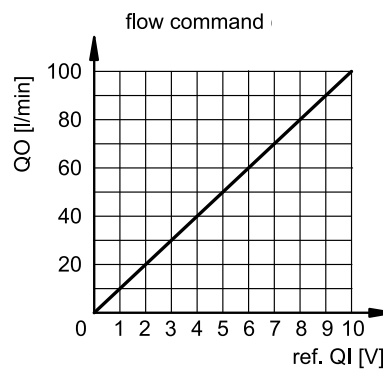
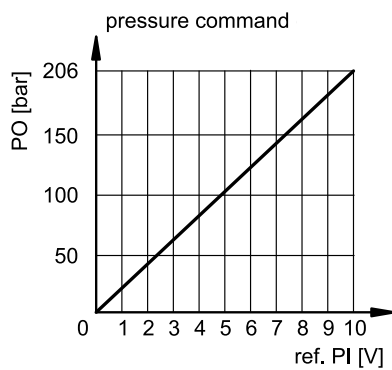

### 4.3 - SUT00S10021-40YN-DA circuit block diagram (basic version)

The customer is responsible for the discharge manifold of the motor pump. Reference example in point 4.7. The pressure sensor is supplied. For technical details, please refer to section 12.

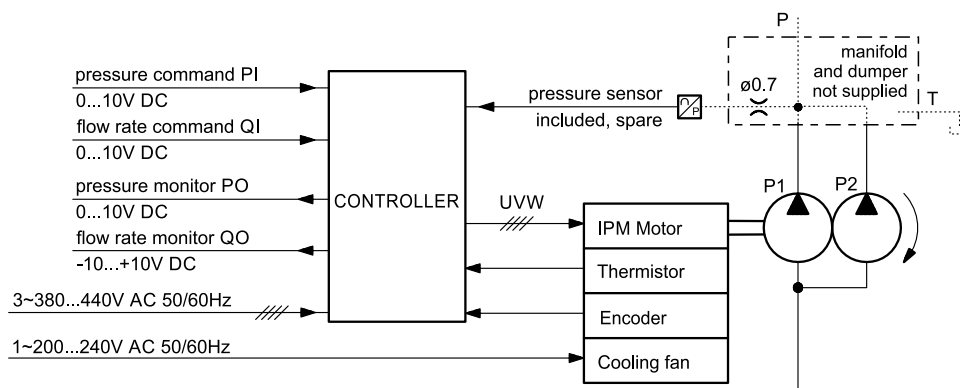

### 4.4 - SUT00S10021-40YP1-DA circuit diagram (with manifold)

The manifold mounted on the motor pump is equipped with a pressure relief valve to protect the pump and the pressure sensor. See details at point 4.7.

See instructions for the pressure relief valve in point 7.4.

### 4.5 - SUT00S10021-40YN-DA overall dimensions (basic version)

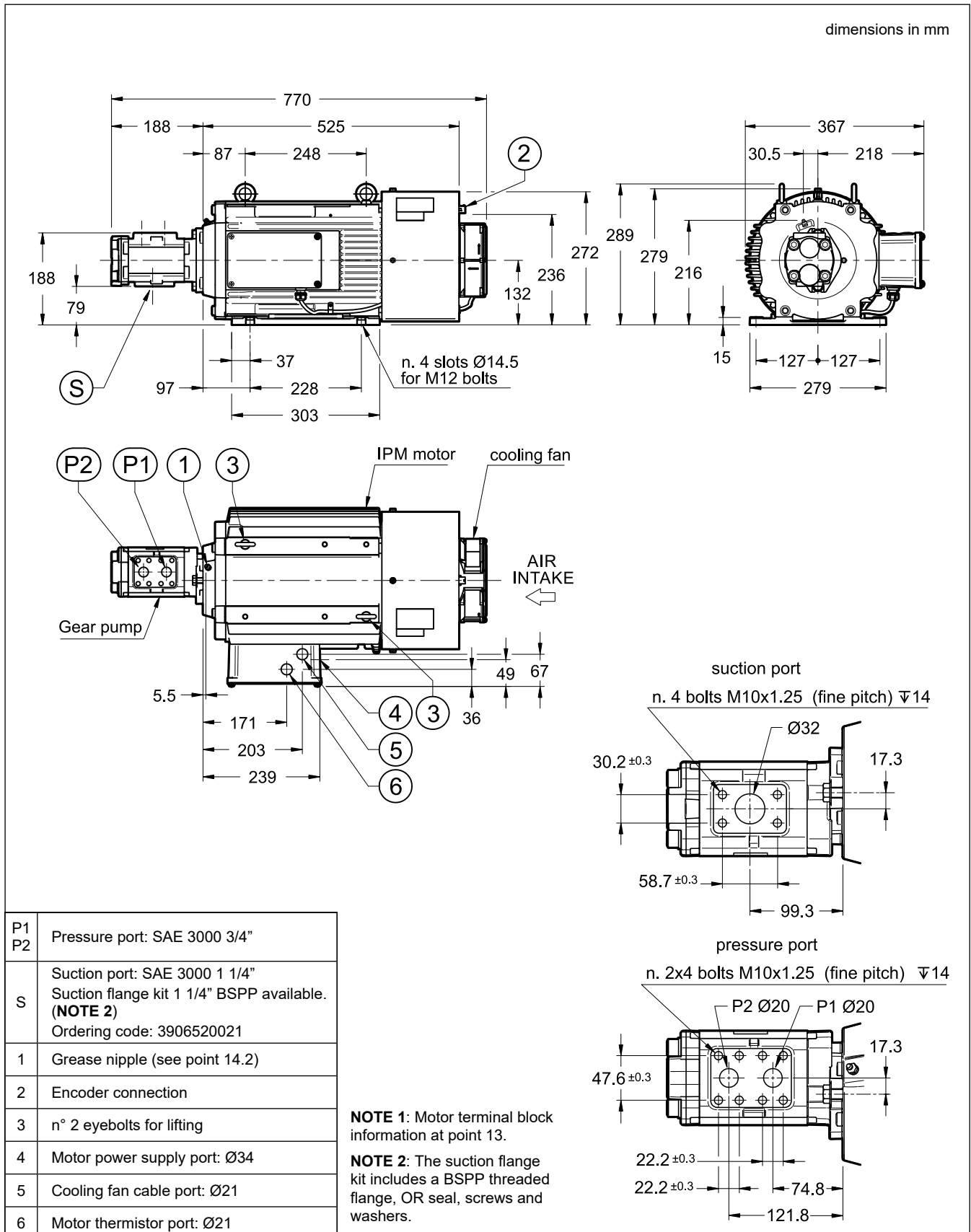

### 4.6 - Controller

Please refer to point 10 to find information relating to the controller for this motor pump.

### 4.7 - SUT00S10021-40YP1-DA overall dimensions (with manifold)

Please refer to the drawing of SUT00S10021-40-YN-DA for missing dimensions.

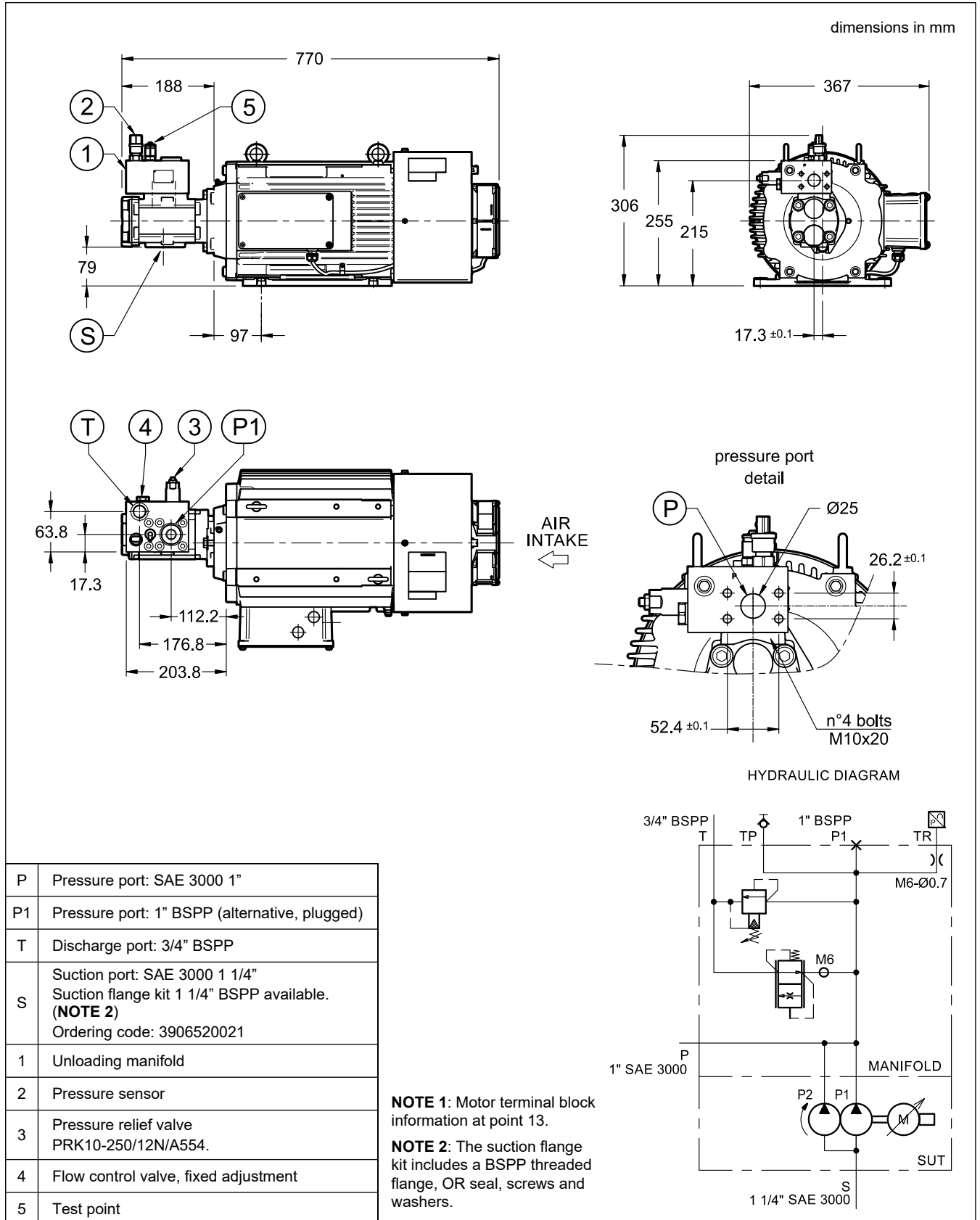

### 4.8 - Controller

Please refer to point 10 to find information relating to the controller for this motor pump.

### 5 - SUT00S13021 (15 KW MOTOR)

Values obtained and rated for ambient temperature  $\leq 40\text{ }^{\circ}\text{C}$  and fluid temperature  $\leq 60\text{ }^{\circ}\text{C}$ .

#### 5.1 - Continuous and Short-Time Operation Limits

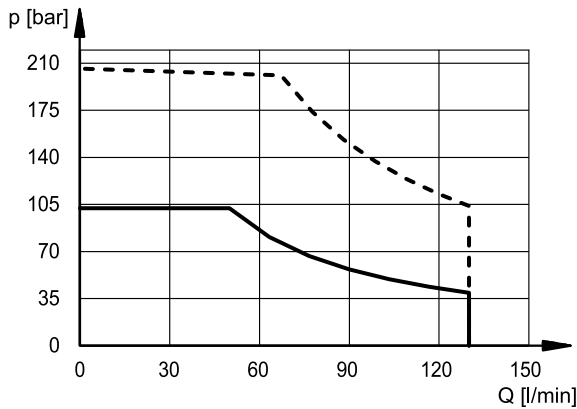

— continuous operation  
 - - - short-time operation ( $\leq 20\%$  of duty cycle time)

The unit is designed for continuous operation (S1) within the range specified in the characteristic chart. Operation may be extended up to 60 seconds within the short-time rating, provided it does not exceed 20% of the duty cycle.

#### 5.2 - p/Q command

The accuracy of both pressure and flow command is  $\leq 0.1\%$  within the entire working cycle.

The 0 V command corresponds to the minimum operating pressure/flow value as specified on page 3, Table 2.

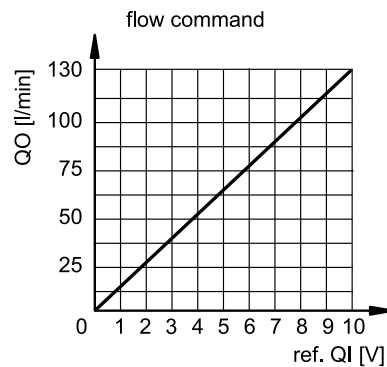
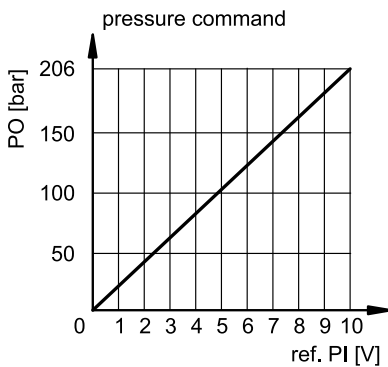

#### 5.3 - SUT00S13021-40YN-DA Circuit block diagram (basic version)

The customer is responsible for the discharge manifold of the motor pump. Reference example in point 5.7. The pressure sensor is supplied. For technical details, please refer to section 12.

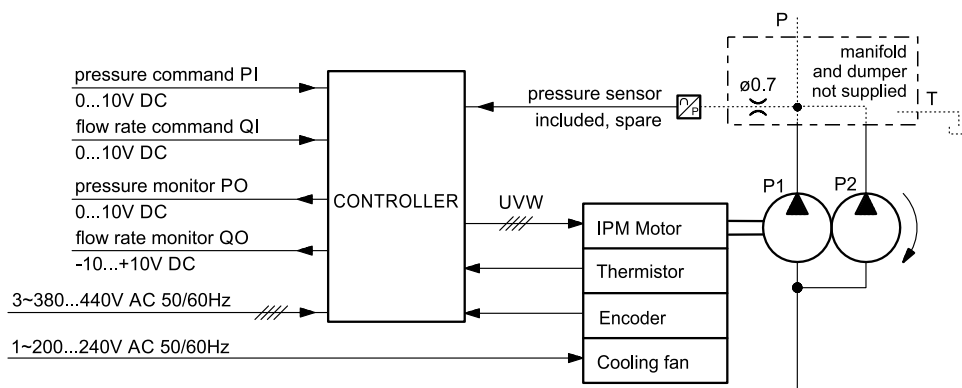

#### 5.4 - SUT00S13021-40YP1-DA circuit diagram (with manifold)

The manifold mounted on the motor pump is equipped with a pressure relief valve to protect the pump and the pressure sensor. See details at point 5.7.

See instructions for the pressure relief valve in point 7.4.

### 5.5 - SUT00S13021-40YN-DA Overall dimensions (basic versions)

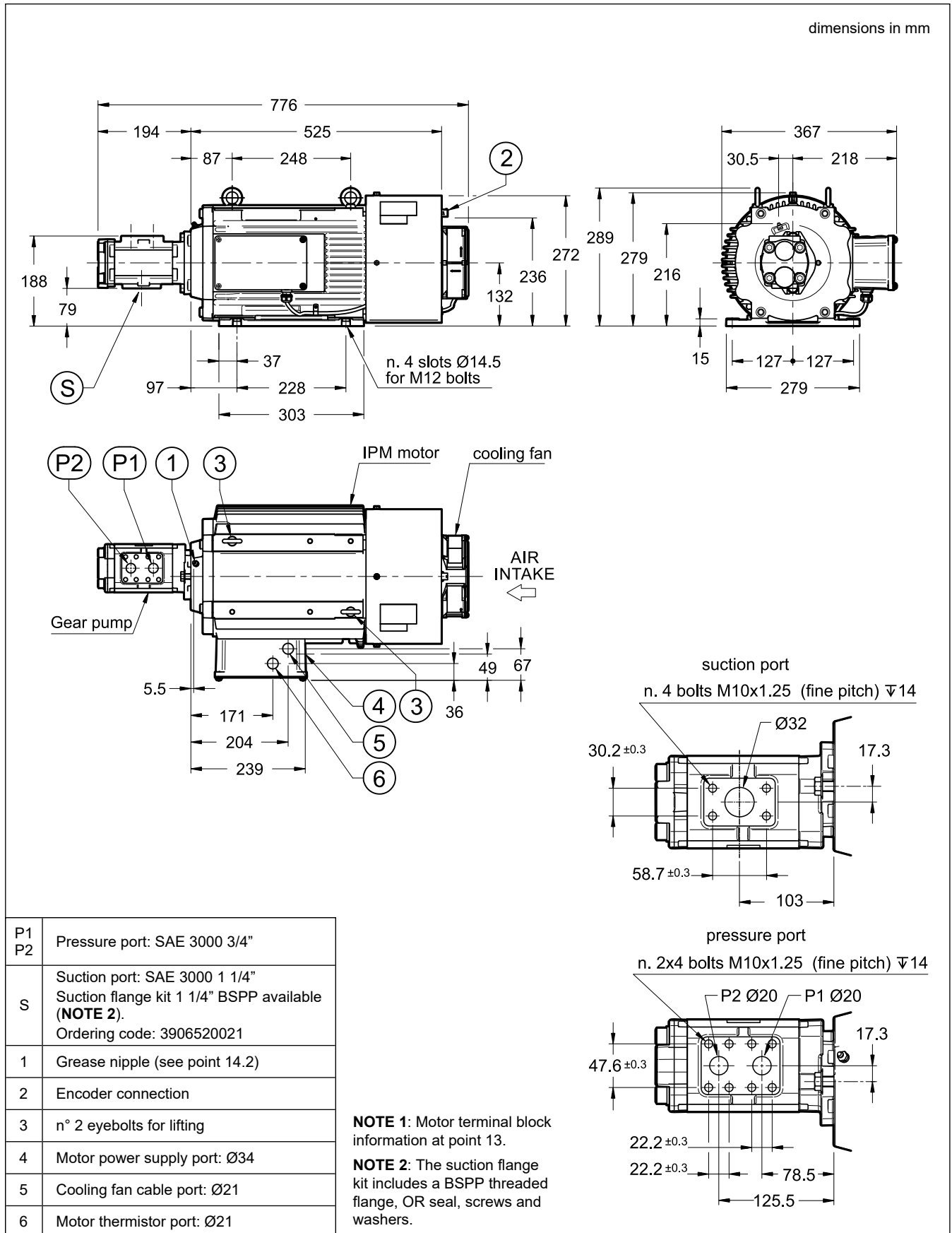

### 5.6 - Controller

Please refer to point 10 to find information relating to the controller for this motor pump.

### 5.7 - SUT00S13021-40YP1-DA Overall dimensions (with manifold)

Please refer to the drawing of SUT00S13021-40YN-DA for missing dimensions.

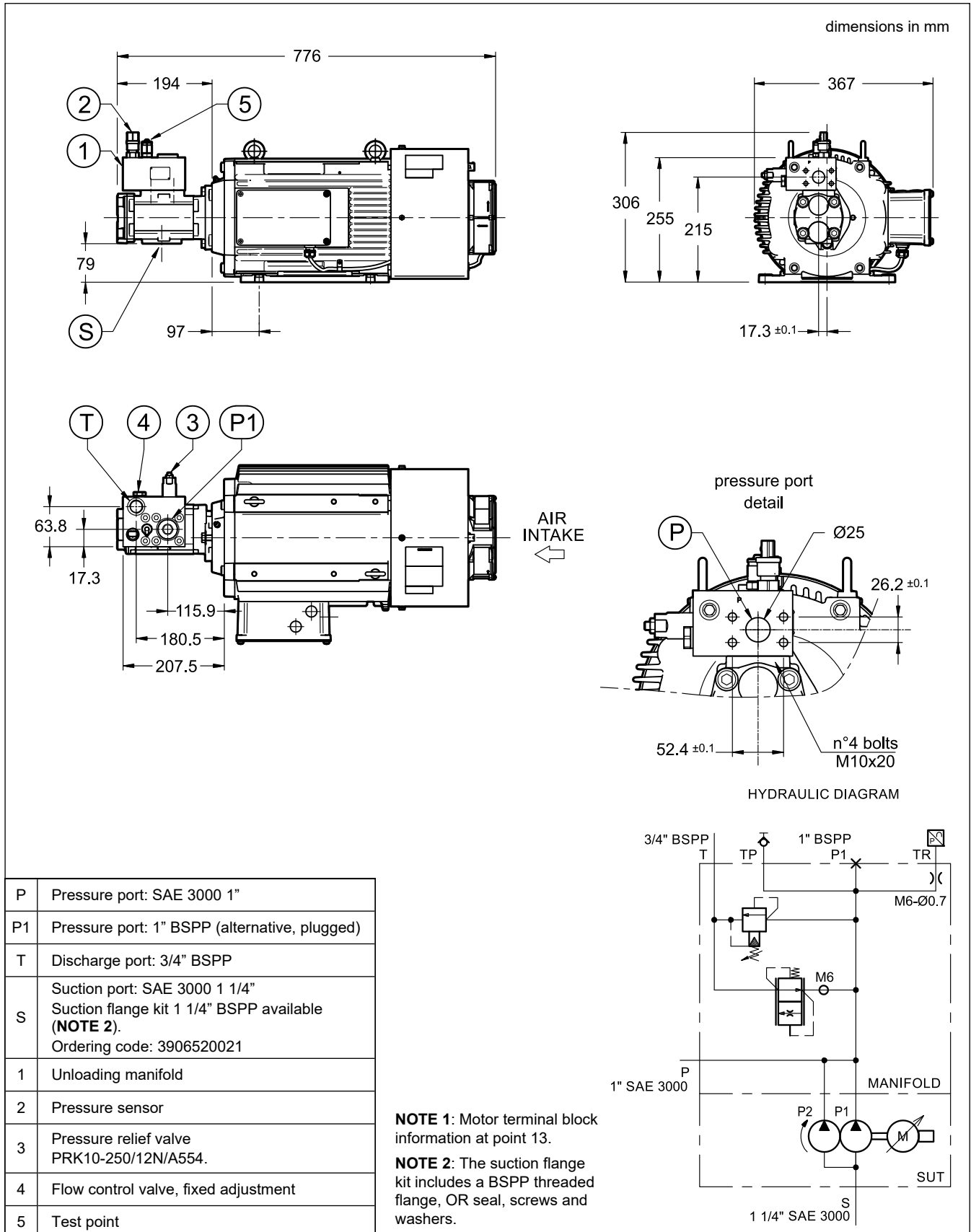

### 5.8 - Controller

Please refer to point 10 to find information relating to the controller for this motor pump.

## 6 - SUT00D\*- DOUBLE PUMP UNIT OPERATION

Double pump type units enable selection between combined flow rates or single flow rate. A dedicated solenoid valve controlled by the SUT or the PLC of the main machine, depending on the parameter setting, switches between low pressure with high flow and high pressure with low flow to avoid overloading the electric motor, as often required in the duty cycles for presses and other machinery.

As an alternative to pressure and flow control with an analogue signal, the duty cycle can be easily set using the programmable set of 3-bit digital ON/OFF signals, which can recall up to eight different pressure/flow patterns.

## 7 - SUT00D8021 (11 KW MOTOR)

Values obtained and rated for ambient temperature  $\leq 40\text{ }^{\circ}\text{C}$  and fluid temperature  $\leq 60\text{ }^{\circ}\text{C}$ .

### 7.1 - Continuous and Short-Time Operation Limits

The SUT00D8021 The unit operates continuously within the range given in the characteristic chart. However, the range of operation can be extended within the short-time rating range for up to 20 seconds, provided it does not exceed a 20% of the duty cycle.

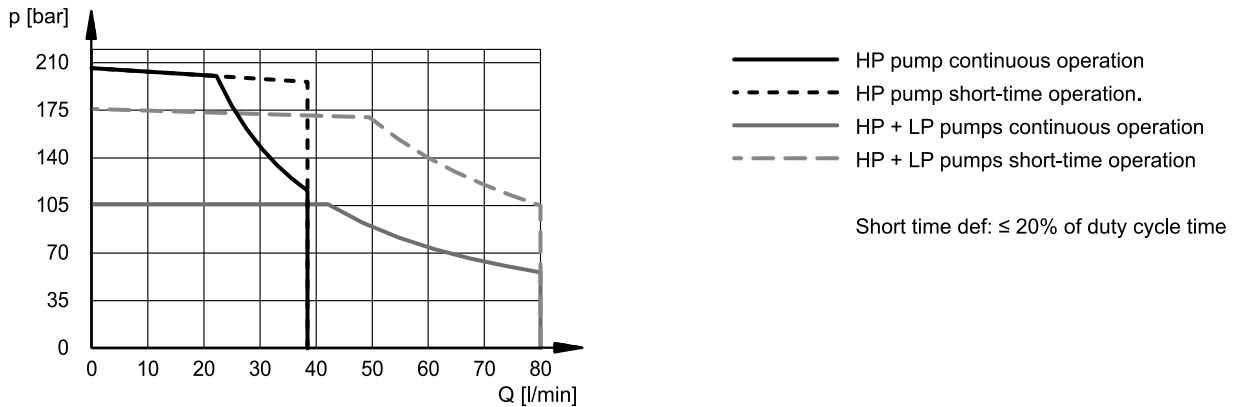

### 7.2 - p/Q commands (analogue input)

Diagrams below show the behaviour of the p/Q commands both in combination flow mode and in single flow mode. The 0 V command corresponds to the minimum operating pressure/flow value as specified on page 3, Table 2.

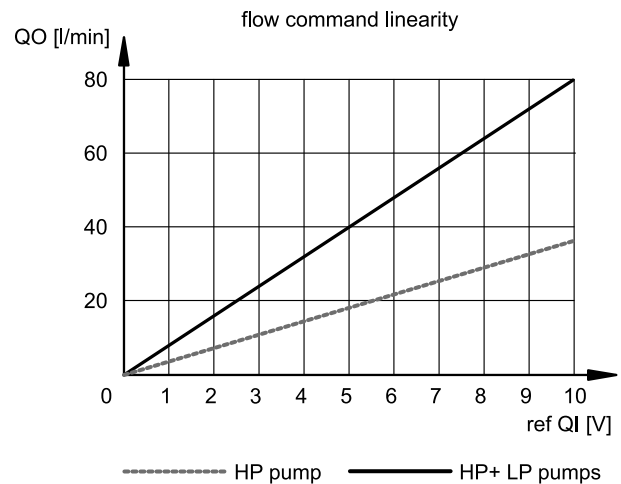
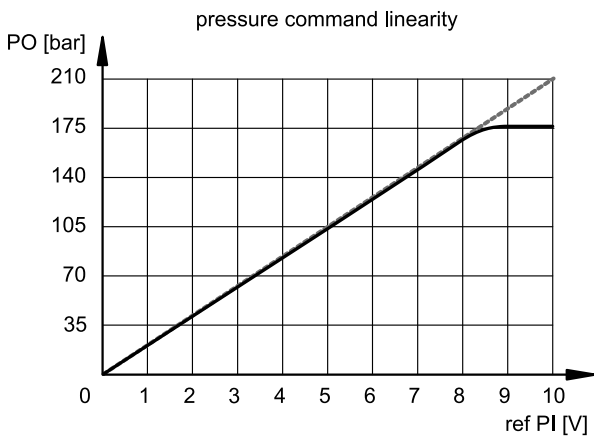

### 7.3 - SUT00D8021-40YN-DA Circuit diagram (basic version)

The flow rate switching circuit between single pump and combined pumps must be prepared by the customer. Reference example in section 7.4.

The pressure sensor is supplied as standard. For technical details, refer to chapter 12.

For cycles with a pressure-hold phase that exceeding 3 minutes, a bleed-off line must be provided on the discharge side of the PH pump to ensure adequate cooling.

The bleed-off flow rate must match the flow delivered by the pump at 150 rpm.

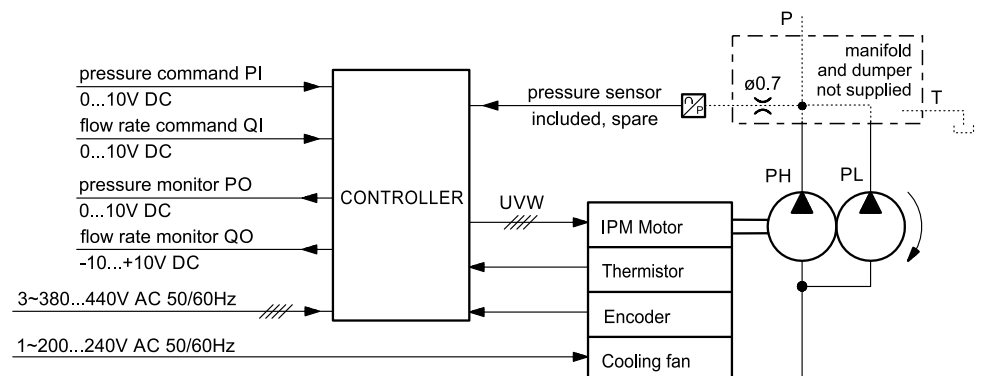

### 7.4 - SUT00D8021-40YP2-DA circuit diagram (with manifold)

The manifold mounted on the motor pump is equipped with a pressure relief valve to protect the high-pressure pump.

To prevent overloading of the electric motor, the driver controls the solenoid valve by discharging the flow of the PL pump, typically when the pressure measured by the sensor at the TR point exceeds 70 bar (indicative value, depending on the analogue commands and the parameters set controller-side).

Both pumps work below this value.

Below are the main characteristics of the components for which actions by the customer are required during commissioning.

#### PRESSURE RELIEF VALVE

**description:** PRK10-250/12N/A554

Adjust the valve to 10 ÷ 15 bar above the operating pressure of the motor pump.

- pressure gain: 47 bar / turn
- locknut tightening: spanner 13

#### SOLENOID SWITCHING VALVE

**description:** DS5-SA2/14N-D24K1/F

The controller (output D03) drives a power relay which in his turn will switch the DS5 solenoid valve.

Power relay and 24V DC valve power supply are the responsibility of the Customer.

electrical data of the solenoid valve :

	Nominal voltage [V]	Resistance at 20°C [Ω]	Current consumpt. [A]	Power consumpt. [W]	IP degree (NOTE)
<b>DC</b>	24	12	2	48	IP65

cable: 1.5 mm<sup>2</sup>

relay requirements: 24V DC (max 50 mA) coil, single stable, with diode coil surge killer, 24V DC 5A / 220V AC 5A contact rating.

Refer to catalogue 41 310 for more details on the solenoid valve.

**NOTE:** The IP protection degree IEC 60529 is only guaranteed when the equivalent IP-rated connector is connected and installed correctly.

Electrical connector type EN 175301-803 available separately. See catalogue 49 000.

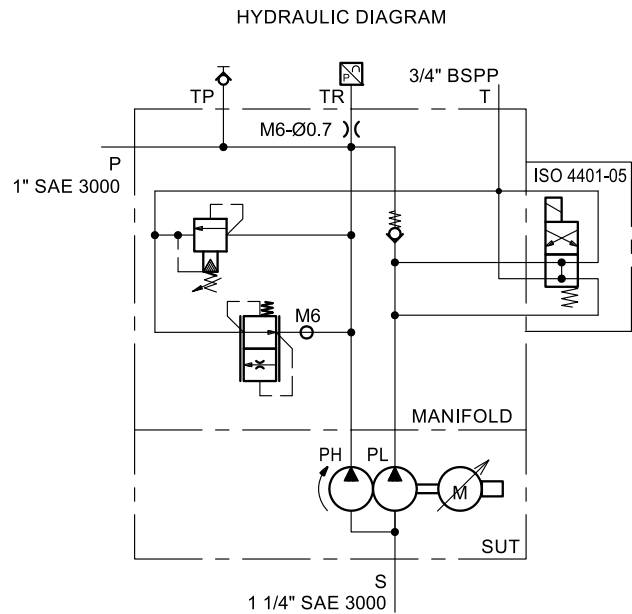

PL pump discharge through solenoid valve

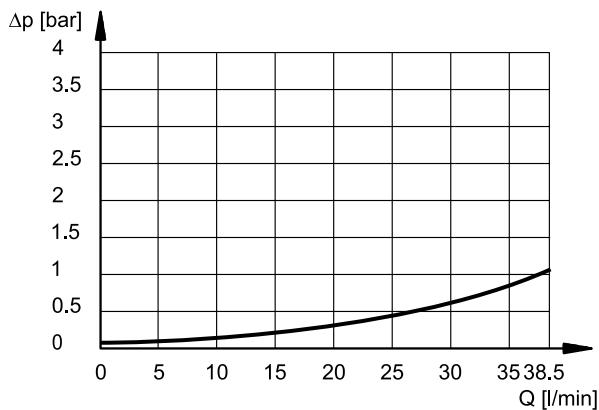

manifold Δp (P path)

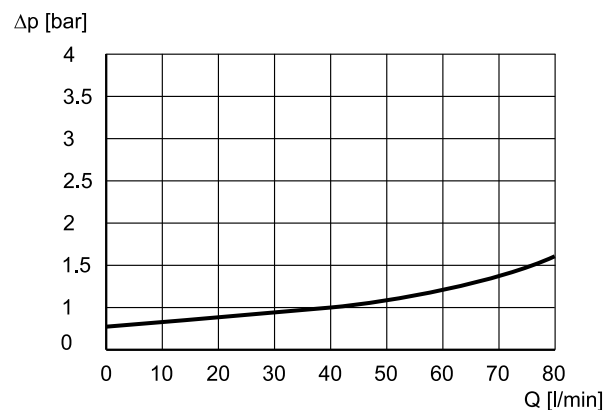

### 7.5 - SUT00D8021-40YN-DA Overall dimensions (basic version)

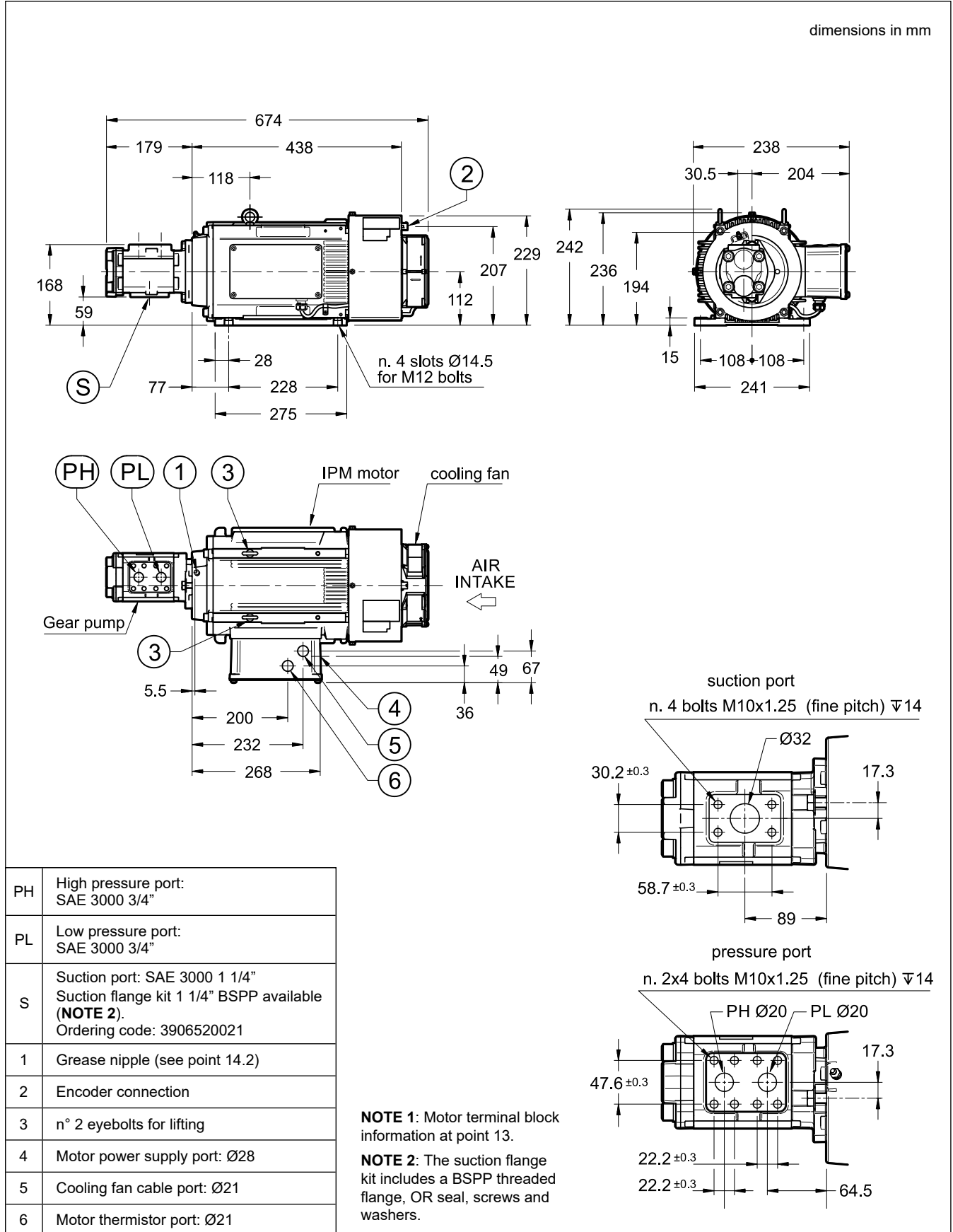

### 7.6 - Controller

Please refer to point 10 to find information relating to the controller for this motor pump.

### 7.7 - SUT00D8021-40YP2-DA Overall dimensions (with manifold)

Please refer to the drawing of SUT00D8021-40YN-DA for missing dimensions.

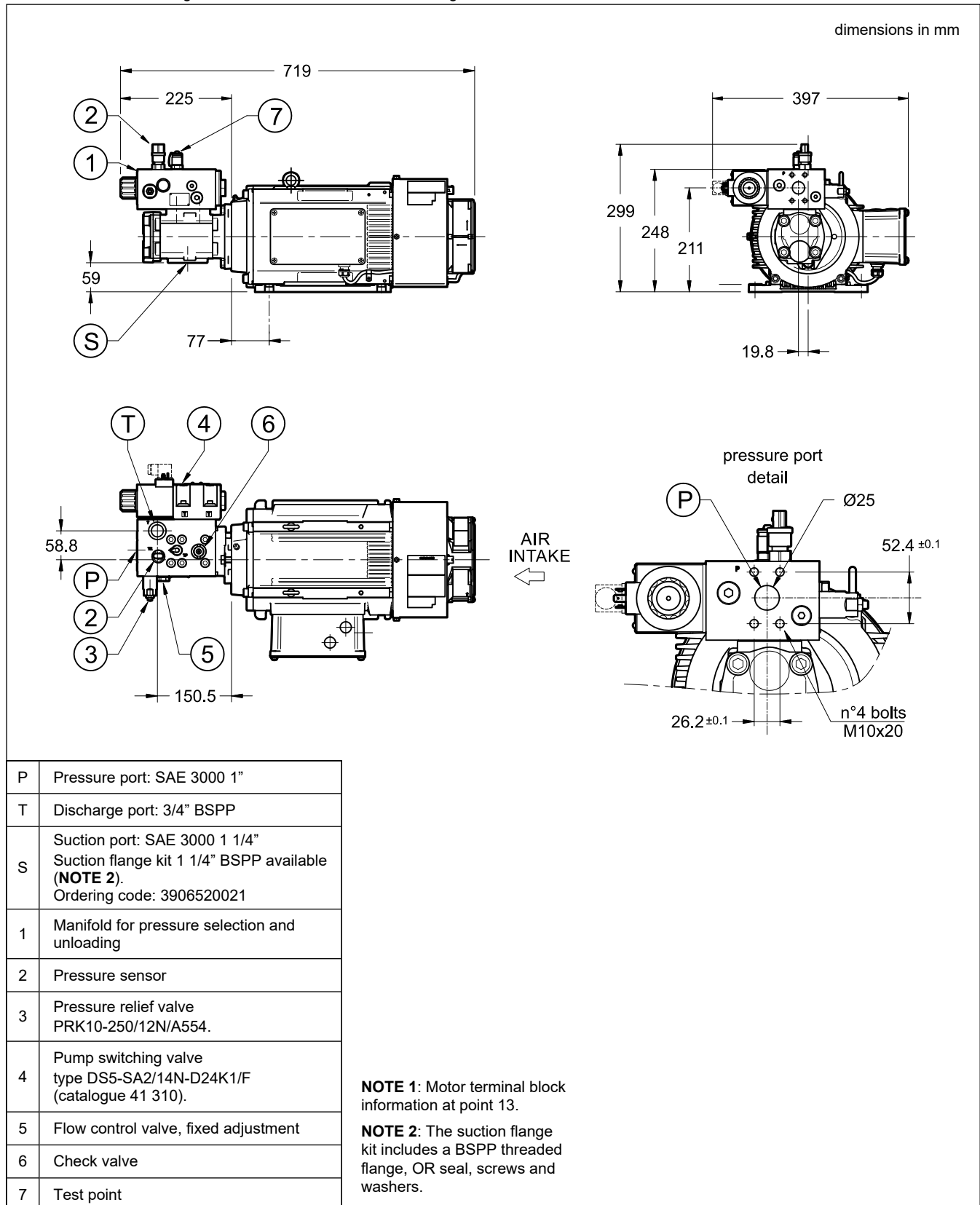

### 7.8 - Controller

Please refer to point 10 to find information relating to the controller for this motor pump.

## 8 - SUT00D15021 (15 KW MOTOR)

Values obtained and rated for ambient temperature  $\leq 40\text{ }^{\circ}\text{C}$  and fluid temperature  $\leq 60\text{ }^{\circ}\text{C}$

### 8.1 - Continuous and Short-Time Operation Limits

The SUT00D15021 unit is designed for continuous operation (S1) within the range specified in the characteristic chart. Operation may be extended up to 20 seconds within the short-time rating, provided it does not exceed 20% of the duty cycle.

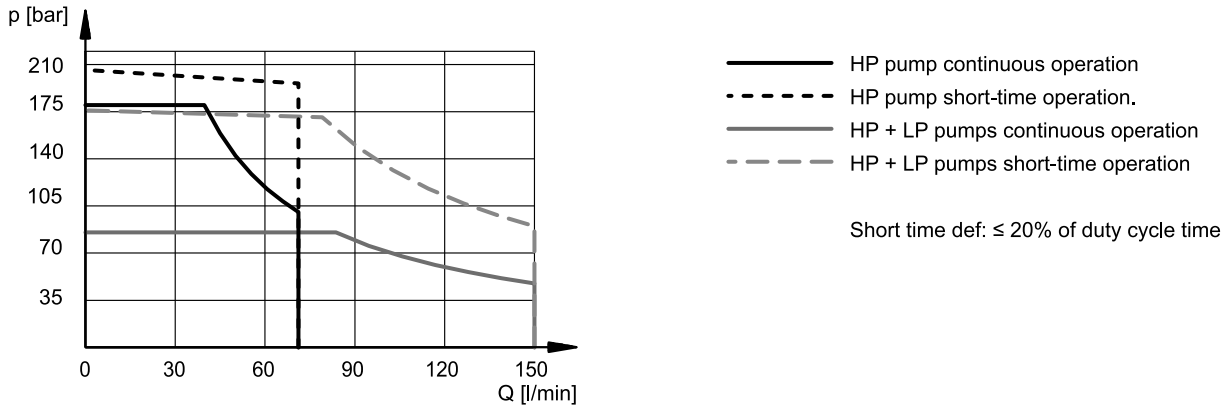

### 8.2 - p/Q commands (analogue input)

Diagrams below show the behaviour of the p/Q commands both in combination flow mode and in single flow mode. The 0 V command corresponds to the minimum operating pressure/flow value as specified on page 3, Table 2.

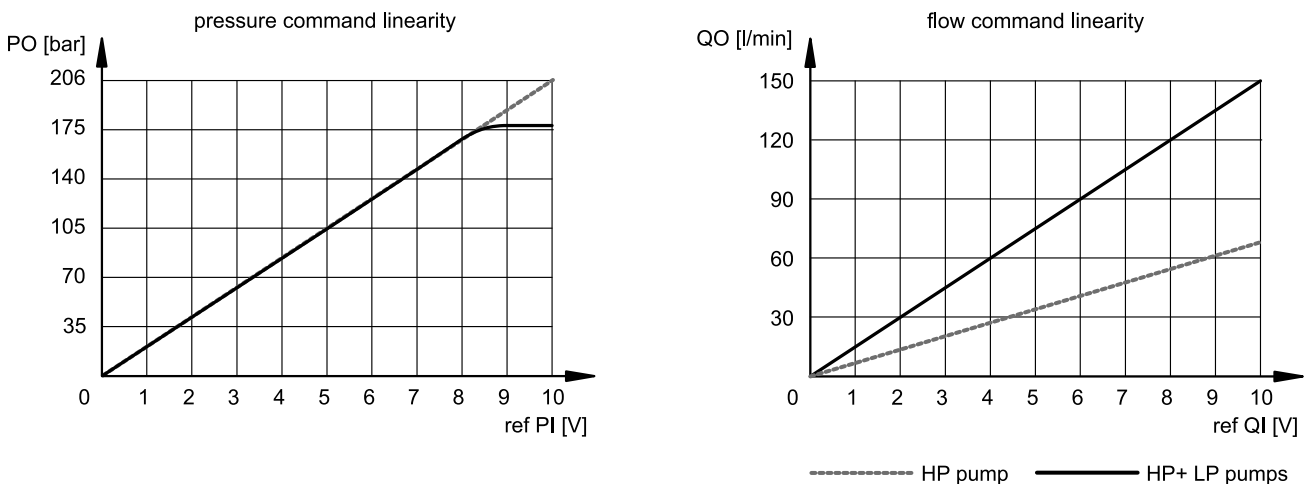

### 8.3 - SUT00D15021-40YN-DA Circuit diagram (basic version)

The flow rate switching circuit between single pump and combined pumps must be prepared by the customer. Reference example in section 8.4. The pressure sensor is supplied as standard. For technical details, refer to chapter 12.

For cycles with a pressure-hold phase that exceeding 3 minutes, a bleed-off line must be provided on the discharge side of the PH pump to ensure adequate cooling. The bleed-off flow rate must match the flow delivered by the pump at 150 rpm.

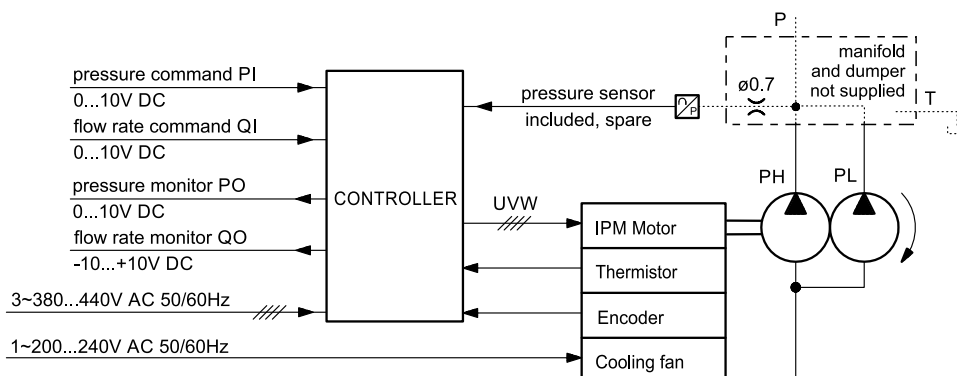

### 8.4 - SUT00D15021-40YP2-DA circuit diagram (with manifold)

The manifold mounted on the motor pump is equipped with a pressure relief valve to protect the high-pressure pump.

To prevent overloading of the electric motor, the driver controls the solenoid valve by discharging the flow of the PL pump, typically when the pressure measured by the sensor at the TR point exceeds 70 bar (indicative value, depending on the analogue commands and on the parameters set controller-side).

Both pumps work below this value.

Below are the main characteristics of the components for which actions by the customer are required during commissioning.

#### PRESSURE RELIEF VALVE

**description:** PRK10-250/12N/A554

Adjust the valve to 10 ÷ 15 bar above the operating pressure of the motor pump.

- pressure gain: 47 bar / turn
- locknut tightening: spanner 13

#### SOLENOID SWITCHING VALVE

**description:** DS5-SA2/14N-D24K1/F

The controller (output D03) drives a power relay which in his turn will switch the DS5 solenoid valve.

Power relay and 24V DC valve power supply are the responsibility of the Customer.

electrical data of the solenoid valve :

	Nominal voltage [V]	Resistance at 20°C [Ω]	Current consumpt. [A]	Power consumpt. [W]	IP degree (NOTE)
DC	24	12	2	48	IP65

cable: 1.5 mm<sup>2</sup>

relay requirements: 24V DC (max 50 mA) coil, single stable, with diode coil surge killer, 24V DC 5A / 220V AC 5A contact rating.

Refer to catalogue 41 310 for more details on the solenoid valve.

**NOTE:** The IP protection degree IEC 60529 is only guaranteed when the equivalent IP-rated connector is connected and installed correctly.

Electrical connector type EN 175301-803 available separately. See catalogue 49 000.

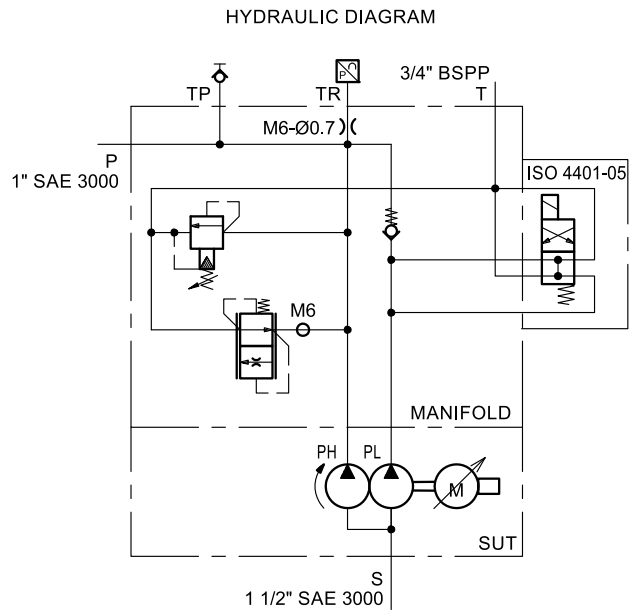

PL pump discharge through solenoid valve

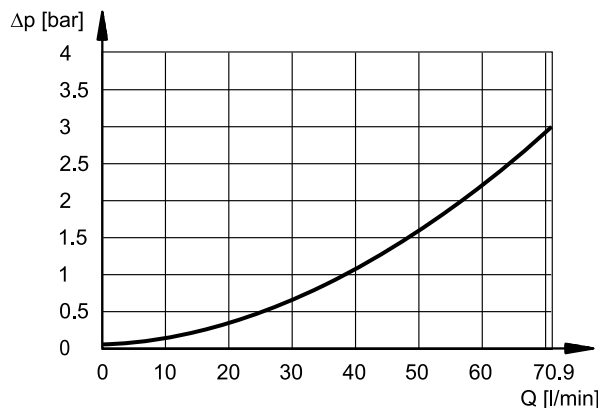

manifold Δp (P path)

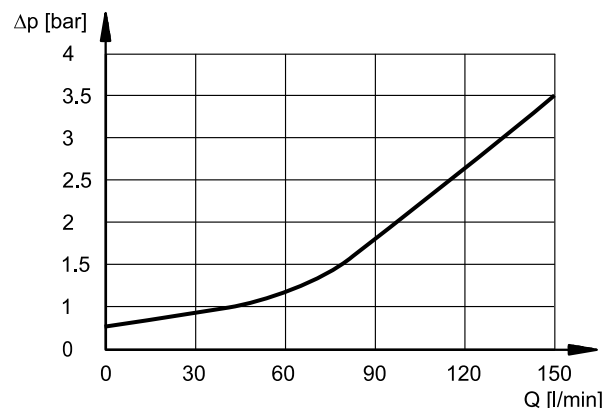

### 8.5 - SUT00D15021-40YN-DA Overall dimensions (basic version)

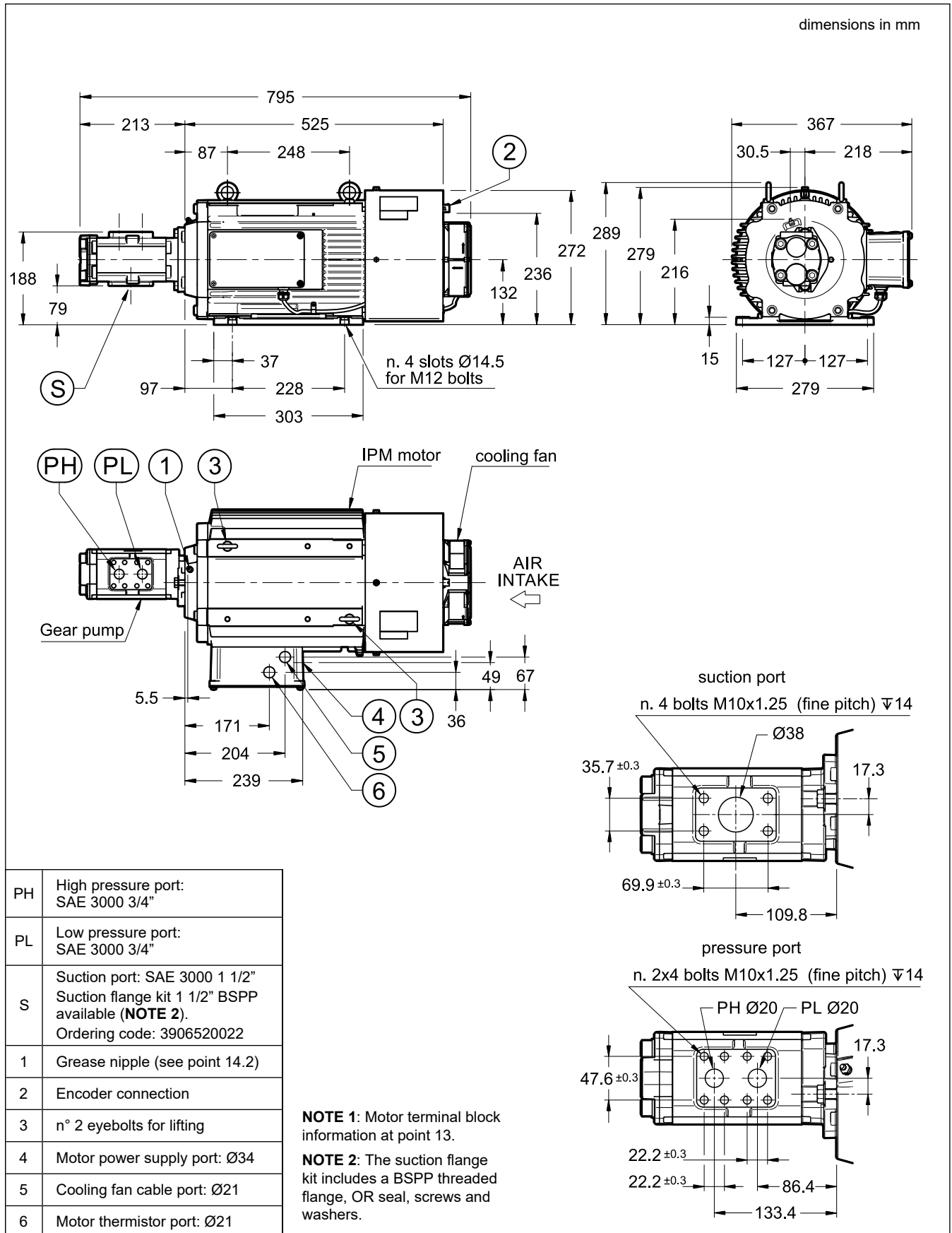

### 8.6 - Controller

Please refer to point 10 to find information relating to the controller for this motor pump.

### 8.7 - SUT00D15021-40YP2-DA Overall dimensions (with manifold)

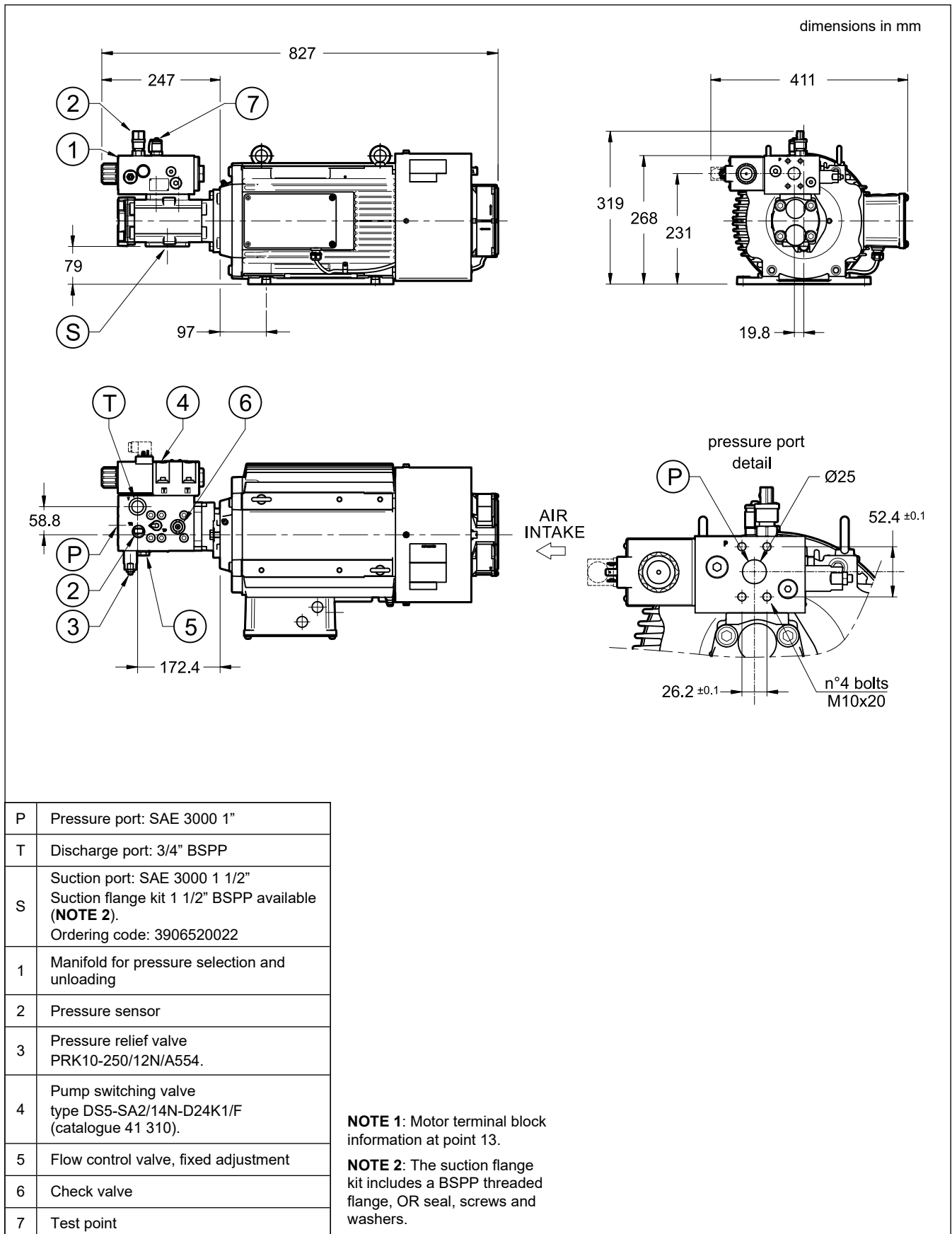

### 8.8 - Controller

Please refer to point 10 to find information relating to the controller for this motor pump.

### 9 - SUT00D20025-40YN-DA (22 KW MOTOR)

Values obtained and rated for ambient temperature  $\leq 40\text{ }^{\circ}\text{C}$  and fluid temperature  $\leq 60\text{ }^{\circ}\text{C}$

#### 9.1 - Continuous and Short-Time Operation Limits

The SUT00D20025 unit is designed for continuous operation (S1) within the range specified in the characteristic chart. Operation may be extended up to 20 seconds within the short-time rating, provided it does not exceed 20% of the duty cycle..

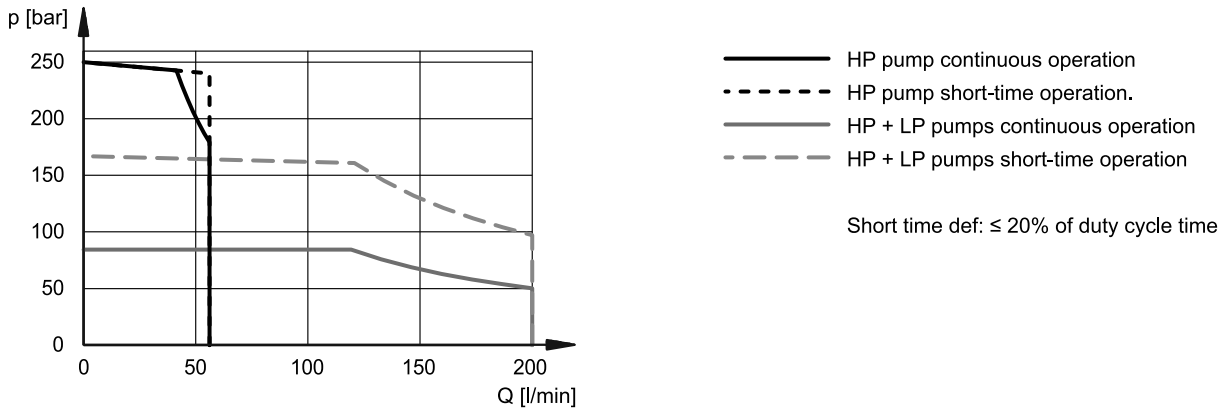

#### 9.2 - p/Q commands (analogue input)

Diagrams below show the behaviour of the p/Q commands both in combination flow mode and in single flow mode. The 0 V command corresponds to the minimum operating pressure/flow value as specified on page 3, Table 2.

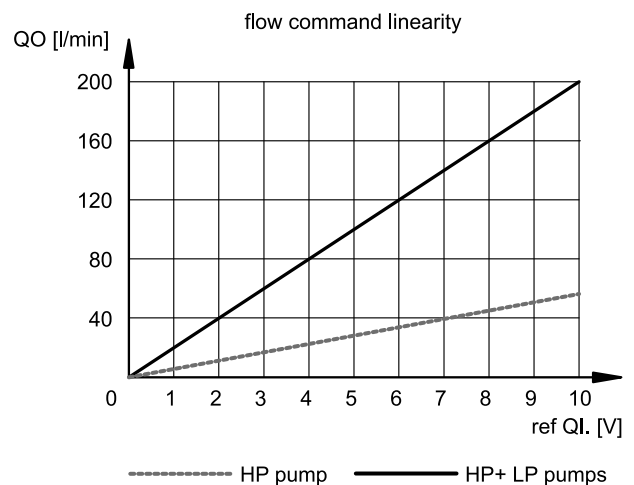
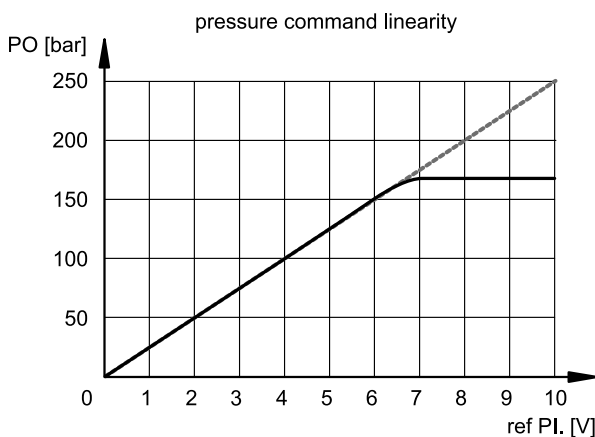

#### 9.3 - Circuit block diagram

The flow rate switching circuit between single pump and combined pumps must be prepared by the customer.

The pressure sensor is supplied as standard. For technical details, refer to chapter 12. The intermediate flange to fit the pressure sensor is available separately (item no. 7 point 9.4).

For cycles with a pressure-hold phase that exceeding 3 minutes, a bleed-off line must be provided on the discharge side of the PH pump to ensure adequate cooling.

The bleed-off flow rate must match the flow delivered by the pump at 150 rpm.

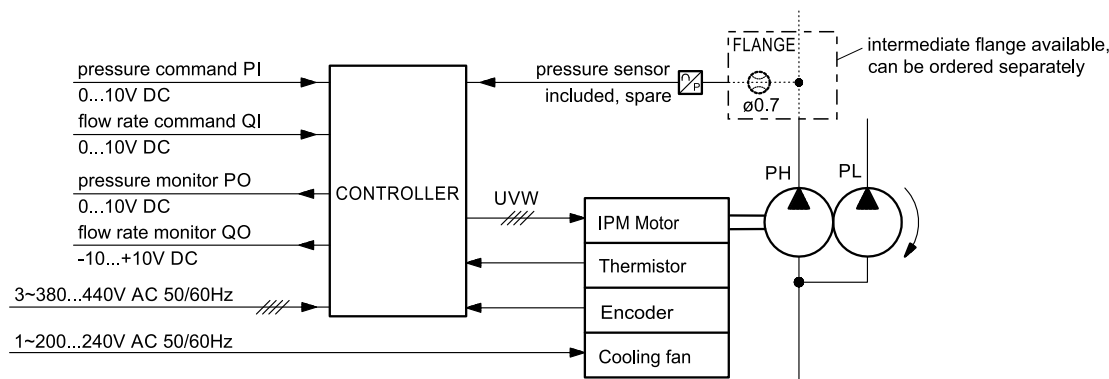

### 9.4 - SUT00D20025-40YN-DA overall dimensions

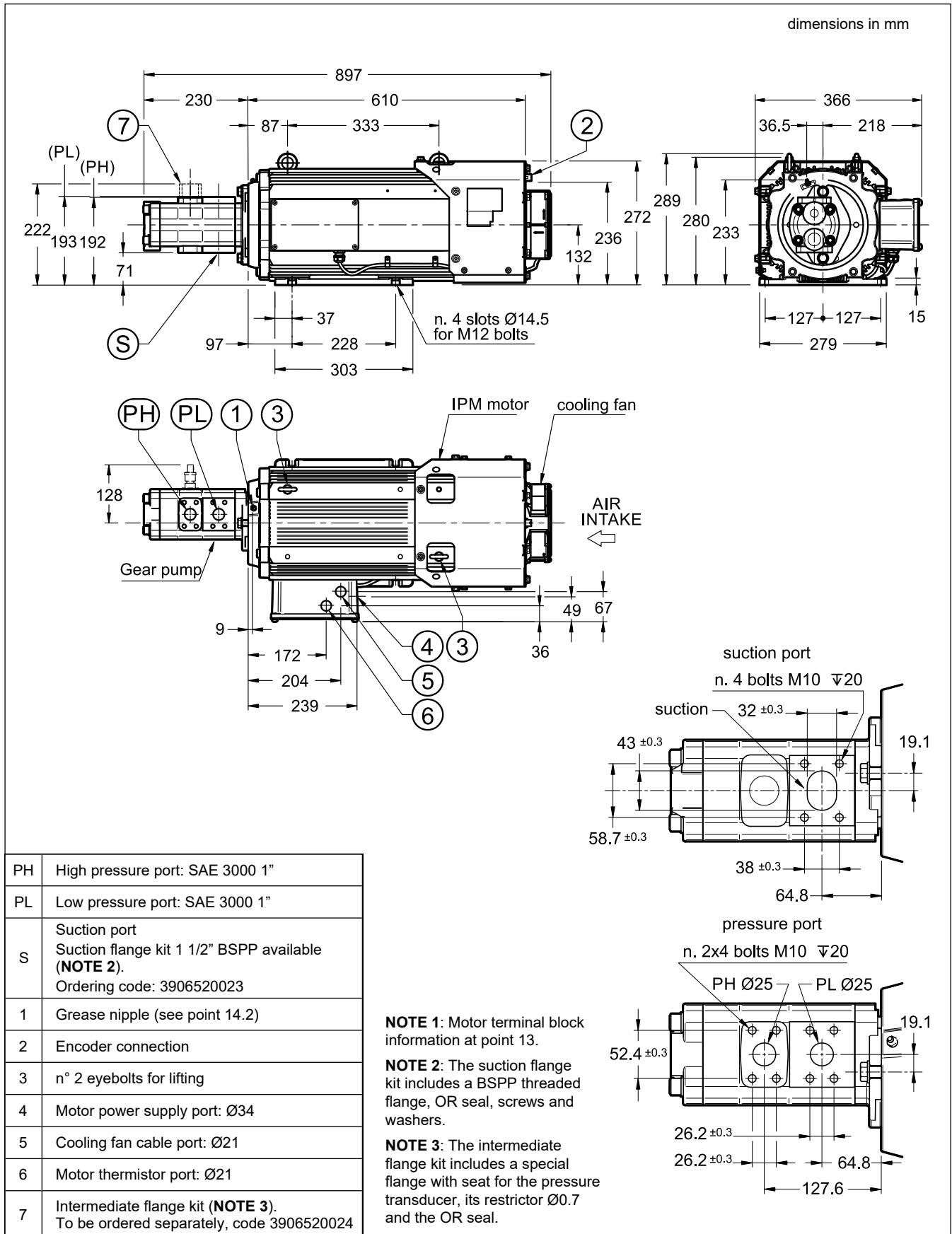

### 9.5 - Controller

Please refer to point 11 to find information relating to the controller for this motor pump.

## 10 - 11 KW AND 15 KW CONTROLLERS

Controllers of SUT00S5021 and SUT00D8021 (11 kW), and SUT00S10021, SUT00S13021 and SUT00D15021 (15 kW) have the same dimensions. Instead, the wiring and the electrical accessories differ depending on the motor power size and on the type of pump (single or double). Please read the installation notes at the end of this catalogue.

### 10.1 - Overall dimensions

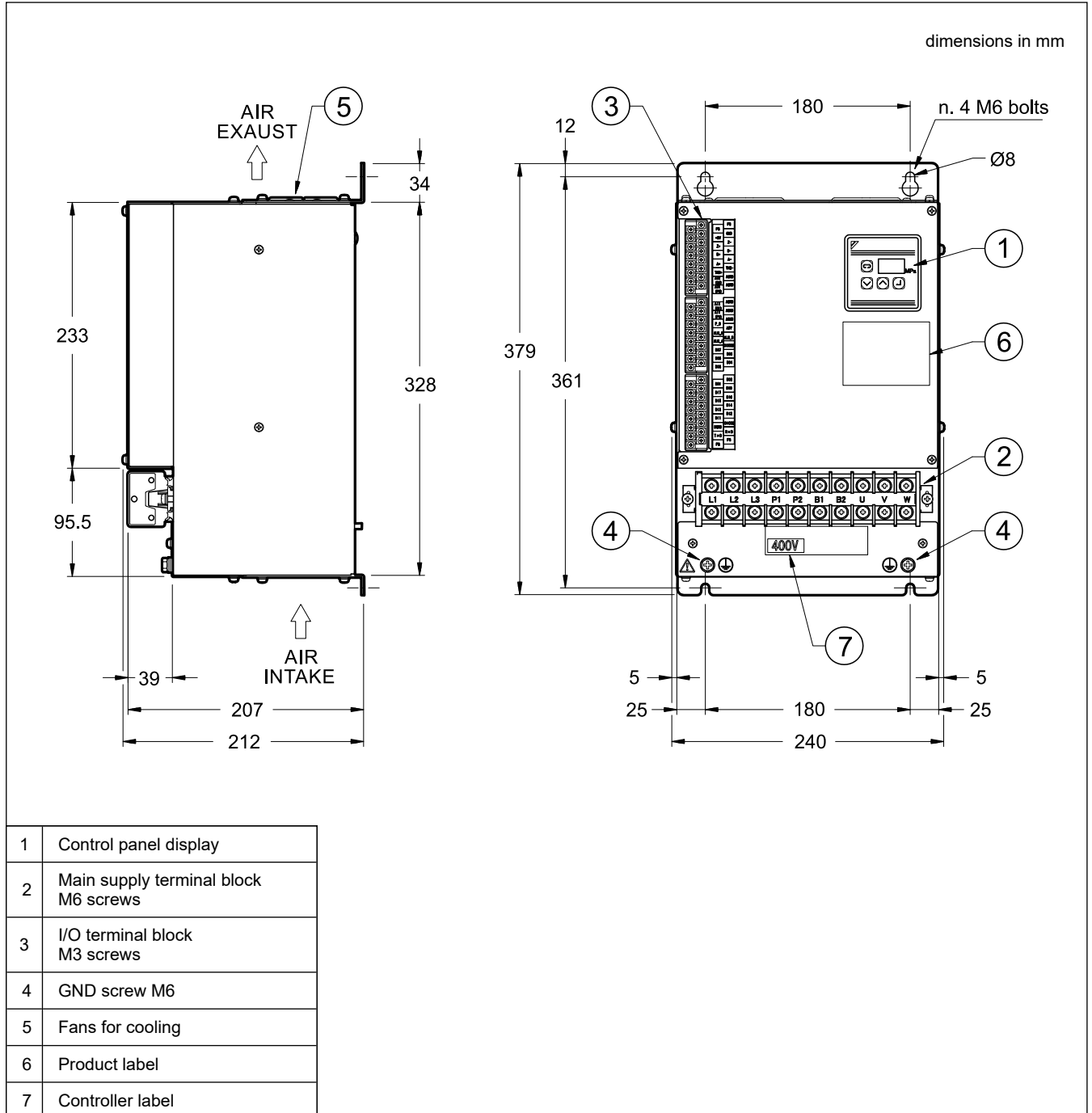



### 10.3 - 11 kW Electrical accessories

This kit is suitable for SUT00S5021 and SUT00D8021. The kit includes the electrical accessories needed to wire the controller, featuring the connection cables for the encoder and the pressure sensor. A DC reactor, effective in improvement of the power factor of the power supply line is also included.

The kit can be ordered separately. Ordering code: **3906520010** PM-SOP23D - 11kW

dimensions in mm

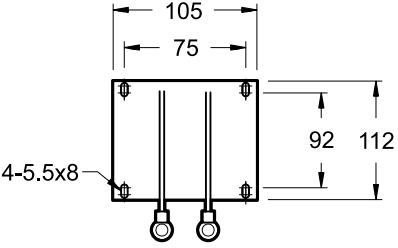
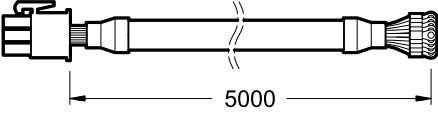
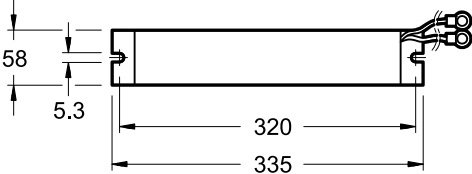
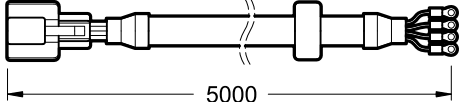
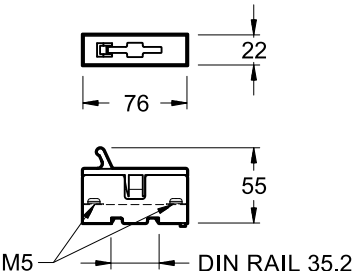
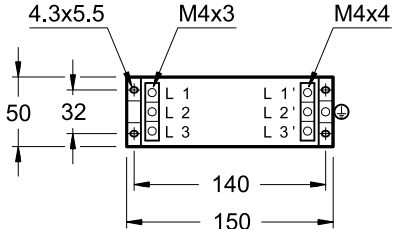
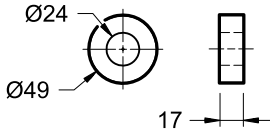
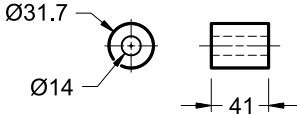
<p><b>DC REACTOR</b>                      <b>labelled as: PM-SLD04</b></p> <p>height:                                95 mm  round terminal:                      M5 with insulating coating  wire length:                          140 mm  Q.ty.                                      1 pc.</p>  <p><b>NOTE:</b> Connect the wire directly to the controller. It cannot be extended.</p>	<p><b>ENCODER HARNESS</b>            <b>labelled as: PM-SEH-P22-A09R</b></p> <p>round terminal:                      M3 with insulating coating  length:                                  5 m  Q.ty                                      1 pc.</p> 
<p><b>BRAKING RESISTOR</b>            <b>labelled as: PM-RB06</b></p> <p>type:                                    68 Ohm / 500 W  height:                                  30 mm  round terminal:                      M4 with insulating coating  wire length:                          500 mm  Q.ty                                      2 pcs.</p>  <p><b>NOTE:</b> When relaying on a terminal block, etc., keep the wire length as short as possible. The resistors must be installed outside the electrical panel, as they heat up a lot.</p>	<p><b>PRESSURE SENSOR HARNESS</b>  <b>labelled as: PM-SPH05-001</b></p> <p>round terminal:                      M3 with insulating coating  length:                                  5 m  Q.ty                                      1 pc.</p> 
<p><b>BRAKING RESISTOR FUSE</b> <b>labelled as: PM-FUD06</b></p> <p>DIN rail width:                      35 mm  built-in fuse type:                  PM-FURB-C0008  Q.ty                                      1 pc.</p> 	<p><b>NOISE FILTER</b>                    <b>labelled as: PM-SNF06</b></p> <p>height:                                  78 mm  Q.ty                                      1 pc.</p> 
<p><b>RING CORE</b>                        <b>labelled as: PM-SRC01</b></p> <p>yellow tape mark  Q.ty                                      3 pcs.</p> 	<p><b>FERRITE CORE</b>                    <b>labelled as: PM-FC01</b></p> <p>Q.ty                                      1 pc.</p> 



### 10.5 - 15 kW Electrical accessories

This kit is suitable for SUT00S10021, SUT00S13021 and SUT00D15021. The kit features the electrical accessories needed to wire the controller, including the connection cables for the encoder and the pressure sensor. A DC reactor, effective in improvement of the power factor of the power supply line, is also included.

The kit can be ordered separately. Ordering code: **3906520011** PM-SOP24D - 15kW

dimensions in mm

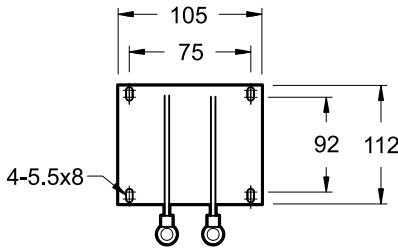
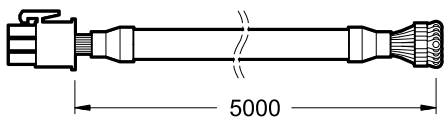
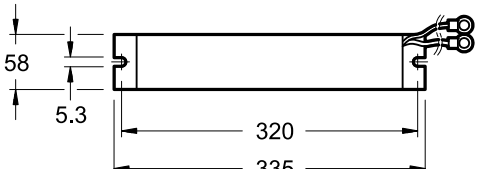
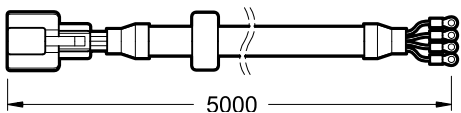
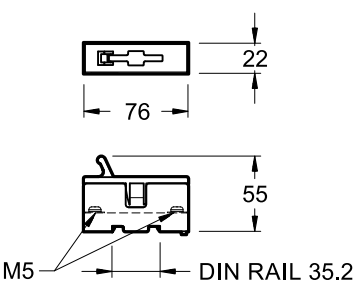
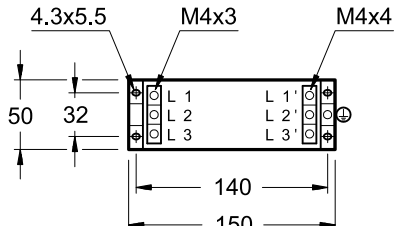
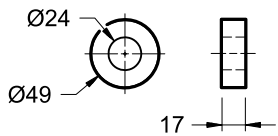
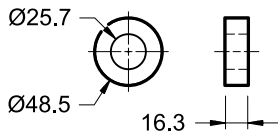
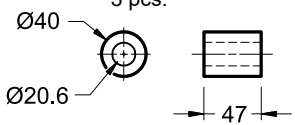
<p><b>DC REACTOR</b>                      <b>labelled as: PM-SLD04</b></p> <p>height:                                95 mm</p> <p>round terminal:                    M5 with insulating coating</p> <p>wire length:                        140 mm</p> <p>Q.ty.                                    1 pc.</p>  <p><b>NOTE:</b> Connect the wire directly to the controller. It cannot be extended.</p>	<p><b>ENCODER HARNESS</b>            <b>labelled as: PM-SEH-P22-A09R</b></p> <p>round terminal:                    M3 with insulating coating</p> <p>length:                                5 m</p> <p>Q.ty                                    1 pc.</p> 
<p><b>BRAKING RESISTOR</b>            <b>labelled as: PM-RB06</b></p> <p>type:                                  68 Ohm / 500 W</p> <p>height:                                30 mm</p> <p>round terminal:                    M4 with insulating coating</p> <p>wire length:                        500 mm</p> <p>Q.ty                                    4 pcs.</p>  <p><b>NOTE:</b> When relaying on a terminal block, etc., keep the wire length as short as possible. The resistors must be installed outside the electrical panel, as they heat up a lot.</p>	<p><b>PRESSURE SENSOR HARNESS</b> <b>labelled as: PM-SPH05-002</b></p> <p>round terminal:                    M3 with insulating coating</p> <p>length:                                5 m</p> <p>Q.ty                                    1 pc.</p> 
<p><b>BRAKING RESISTOR FUSE</b> <b>labelled as: PM-FUD08</b></p> <p>DIN rail width:                    35 mm</p> <p>built-in fuse type:                PM-FURB-C015</p> <p>Q.ty                                    1 pc.</p>  <p>M5                                    DIN RAIL 35.2</p>	<p><b>NOISE FILTER</b>                    <b>labelled as: PM-SNF06</b></p> <p>height:                                78 mm</p> <p>Q.ty                                    2 pcs.</p> 
<p><b>BRING CORE</b> <b>labelled as: PM-SRC01</b> yellow tape mark</p> <p>Q.ty                                    1 pc.</p> 	<p><b>RING CORE</b> <b>labelled as: PM-SRC02</b> green tape mark</p> <p>Q.ty                                    2 pcs.</p> 
<p><b>FERRITE CORE</b>                    <b>labelled as: PM-FC04</b></p> <p>Q.ty                                    3 pcs.</p> 	

## 11 - 22 KW CONTROLLERS

These controllers are supplied with SUT00D20025 models only.

### 11.1 - Overall dimensions

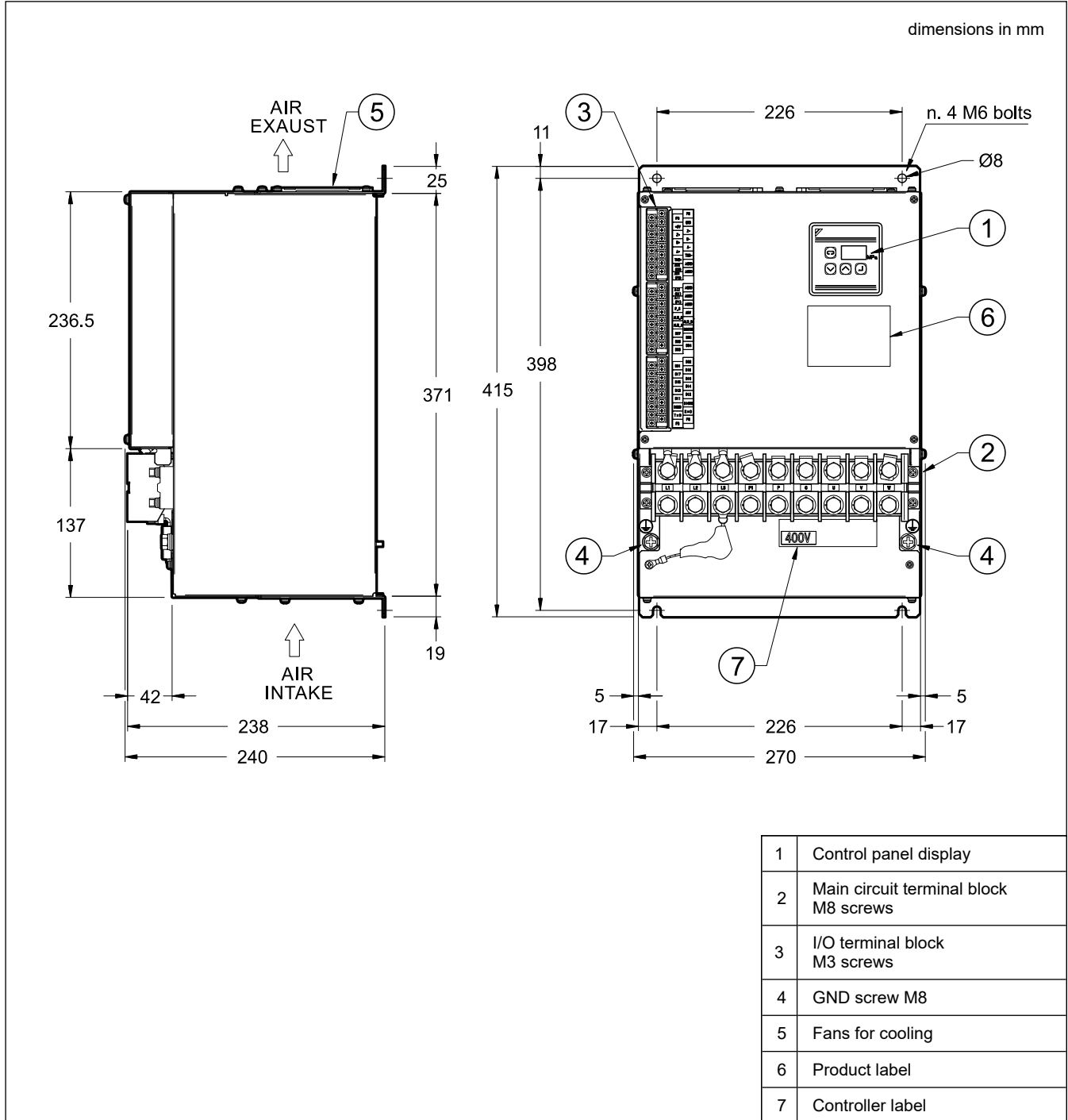

## 11.2 - Wiring diagram of 22 kW controller (for SUT00D20025)

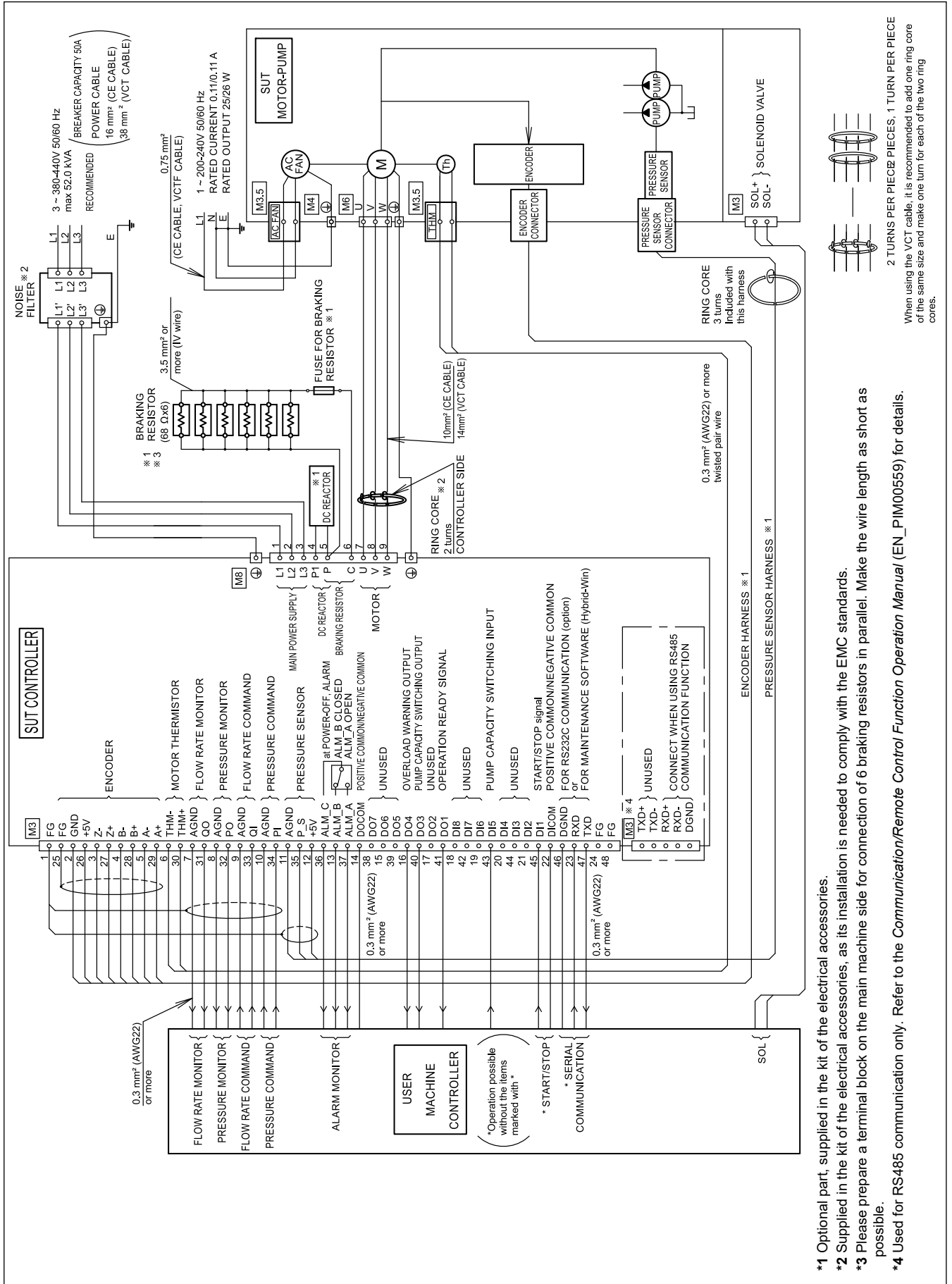

\*1 Optional part, supplied in the kit of the electrical accessories.

\*2 Supplied in the kit of the electrical accessories, as its installation is needed to comply with the EMC standards.

\*3 Please prepare a terminal block on the main machine side for connection of 6 braking resistors in parallel. Make the wire length as short as possible.

\*4 Used for RS485 communication only. Refer to the Communication/Remote Control Function Operation Manual (EN\_PIM00559) for details.

### 11.3 - 22 kW Electrical accessories

This kit is suitable for SUT00D20025. The kit features the electrical accessories needed to wire the controller, including the connection cables for the encoder and the pressure sensor. A DC reactor, effective in improvement of the power factor of the power supply line is also included.

The kit can be ordered separately.

Ordering code: **3906520012** PM-SOP25D - 22kW

dimensions in mm

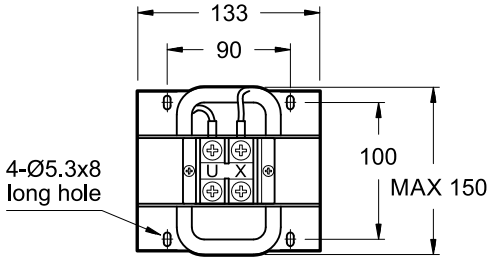
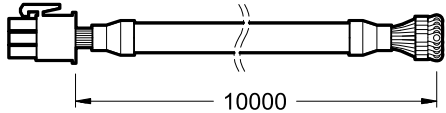
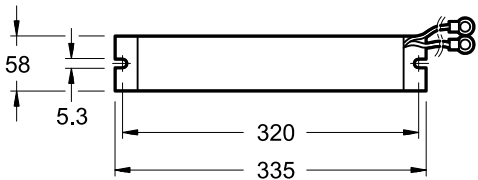
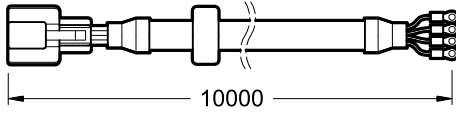
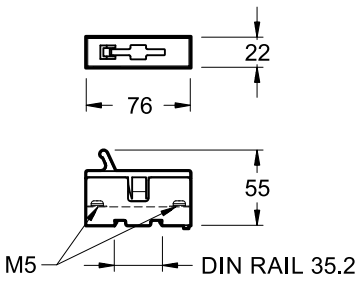
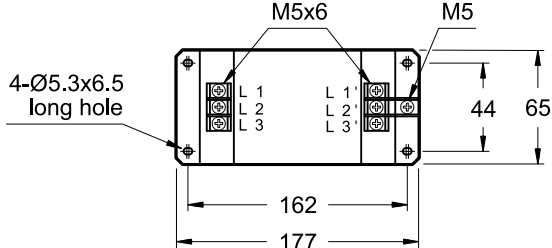
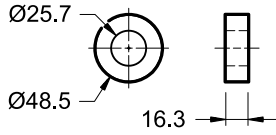
<p><b>DC REACTOR</b>                      <b>labelled as: PM-SLD05</b></p> <p>height:                                180 mm  terminal:                              M8 crimp terminal  wire length:                         140 mm  Qty.                                      1 pc.</p>  <p><b>NOTE:</b> Keep the wire length as short as possible. The wire diameter should be equal or larger than the power cable.</p>	<p><b>ENCODER HARNESS</b>  <b>labelled as: PM-SEH10-P22-A09R</b></p> <p>round terminal:                    M3 with insulating coating  length:                                10 m  Qty.                                    1 pc.</p> 
<p><b>BRAKING RESISTOR</b>            <b>labelled as: PM-RB06</b></p> <p>type:                                  68 Ohm / 500 W  height:                                30 mm  round terminal:                    M4 with insulating coating  wire length:                        500 mm  Qty.                                    6 pcs</p>  <p><b>NOTE:</b> When relaying on a terminal block, etc., keep the wire length as short as possible. The resistors must be installed outside the electrical panel, as they heat up a lot.</p>	<p><b>PRESSURE SENSOR HARNESS</b>  <b>labelled as: PM-SPH10</b></p> <p>round terminal:                    M3 with insulating coating  length:                                10 m  Qty.                                    1 pc.</p> 
<p><b>BRAKING RESISTOR FUSE</b> <b>labelled as: PM-FUD09</b></p> <p>DIN rail width:                    35 mm  built-in fuse type:                PM-FURB-C020  Qty.                                    1 pc.</p> 	<p><b>NOISE FILTER</b>                    <b>labelled as: PM-SNF07</b></p> <p>height:                                84 mm  Qty.                                    1 pc.</p> 
<p><b>RING CORE</b>  <b>labelled as: PM-SRC02</b></p> <p>green tape mark  Qty.                                    1 pc.</p> 	

## 12 - PRESSURE SENSOR

The pressure sensor is supplied boxed with all the SUT basic models. The sensor must be placed as close as possible to the pump delivery (HP pump in SUT00D\*) and, in any case, no more than 1.5 meters from it. SUT models with the manifold on-board are delivered with the pressure sensor already installed.

The pressure sensor harness is included in the kit of the electrical accessories. The kit can be ordered separately.

**NOTE 1: Customers that buy a basic model must provide a fixed throttle Ø0.7 mm upstream the pressure sensor inside their manifold, in order to prevent pressure peaks that may destroy it.**

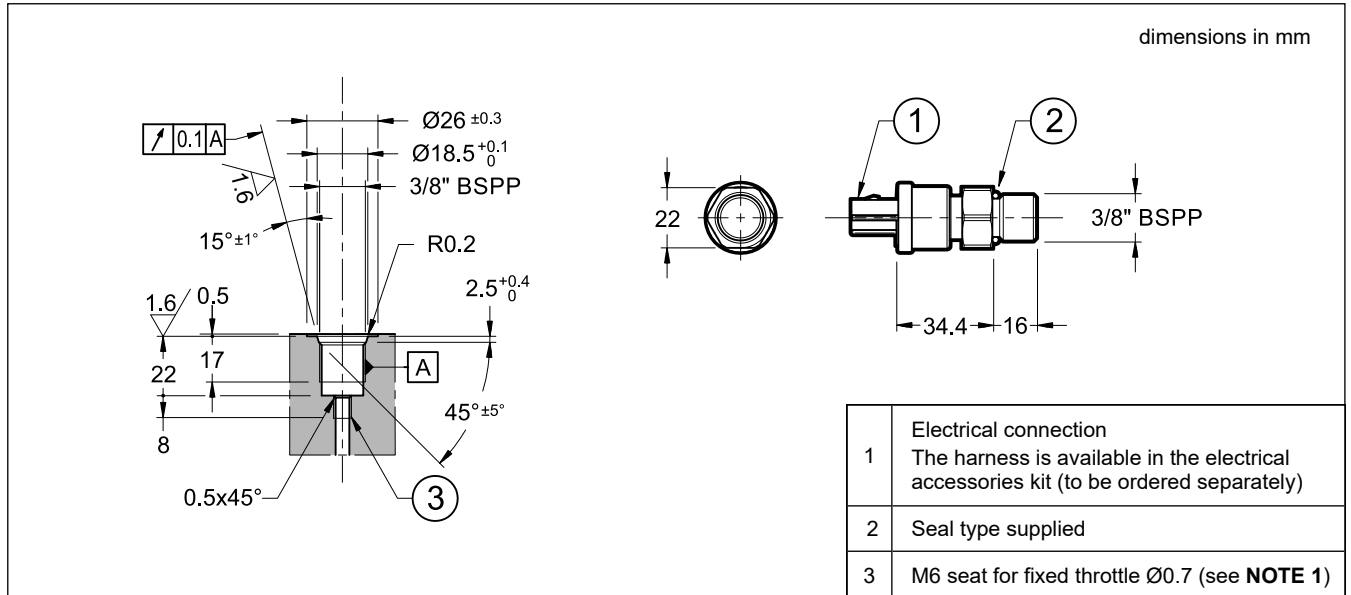

## 13 - MOTOR TERMINAL BLOCK

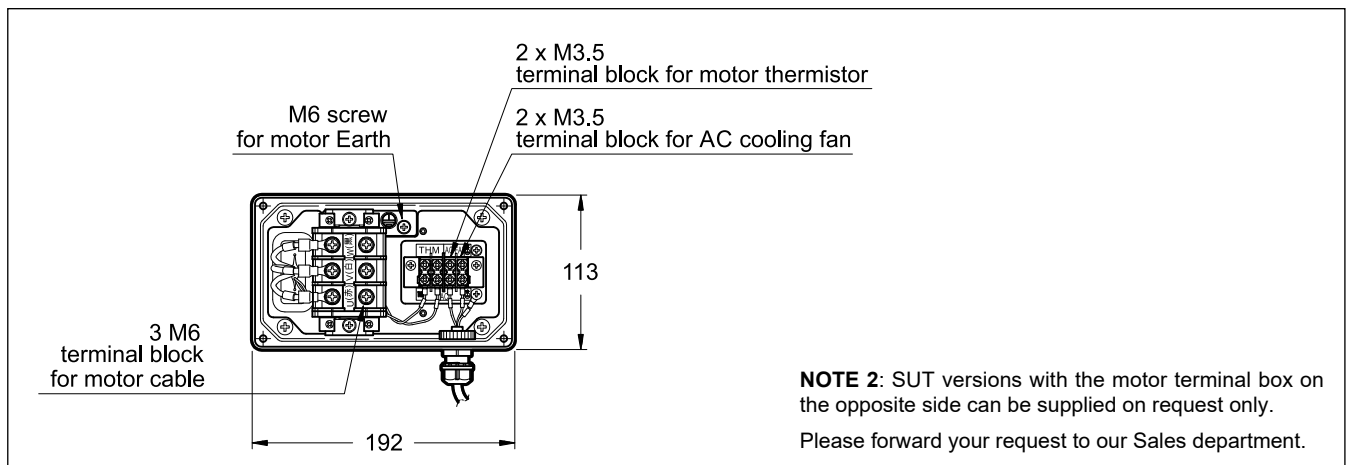

## 14 - INSTALLATION NOTES

### 14.1 - Hydraulic fluid

Use mineral-oil base hydraulic oil. The use of hydraulic oils other than mineral-oil based type (e.g., hydrous/synthetic) is prohibited.

### 14.2 - Lubrication

Grease with a grease gun from the grease nipple regularly. The recommended grease is Shell Stamina Grease: RL-2 or EP-2. The recommended lubrication amount is 70 cm<sup>3</sup>, and the recommended greasing interval is once every 3 months.

### 14.3 - Wiring / installation notes and warnings

- Controllers must be installed vertically, in an electrical cabinet IP54 with proper ventilation.
- Ensure at least 100 mm of clearance space above and below the controller to guarantee sufficient airflow for cooling, and 30 mm on both sides for wiring cables and heat dissipation.
- Ensure at least 100 mm space around the motor pump.
- The allowable fluctuation range of the controller power supply voltage is -20...+10%. Even if the power supply voltage is within the allowable

range, a power supply voltage fluctuation in the positive direction may result in an alarm output (regenerative overload etc.), depending on the operating condition and load condition, causing the pump to stop.

- If the load voltage is large, excessive regenerative power is generated when the controller power supply is turned OFF in high-pressure holding status, which may result in damage to the controller. Do not turn OFF the power supply in high-pressure holding status.
- Basic models are without safety valve. Be sure to install a safety valve on the main machine side.
- Models with unloading manifold are equipped with a pressure relief valve (PRK10) for safety function. The PRK10 is supplied with adjustment at minimum value. **The adjustment must be set during the commissioning of the system at 10÷15 bar more than the working pressure of the motor pump.** The working pressure of the motor pump is settable from the SUT control panel.
- Do not provide any in-line check valve on the delivery port, or load pressure reduction control will be disabled.
- To operate this unit in a circuit with an accumulator, protect the pump with a check valve to prevent reverse flow of hydraulic oil from the accumulator to the pump.
- When the power supply is turned OFF, the motor serves as a generator due to reverse flow of hydraulic oil, causing damage to the controller. If load is applied to the pump when the power supply is ON, the motor may not start up properly. Keep the pump under no load for 5 seconds after power-ON.
- Provide a surge absorber for each inductive load connected around the controller (electromagnetic contactor, electromagnetic relay, electromagnetic valve, solenoid, electromagnetic brake, etc.).
- To start and stop the hydraulic unit, use the start and stop signals of the unit, without using an electromagnetic contactor. Make sure that the hydraulic unit has completely stopped before turning the electromagnetic contactor ON/OFF. Otherwise, power supply circuit devices may be damaged.
- Be sure to connect the neutral point of the power supply to a ground line. If the insulation distance is too short, it may cause a failure of the hydraulic unit.

## 15 - SETTING FUNCTIONS REMOTELY

### 15.1 - Managing the pressure and flow rate from a machine

The information that the SUPER UNIT outputs during machine operation, such as pressure and flow rate, can be displayed on the monitor at a machine. RS232C is adopted for the serial communication interface. Provide a controller such as a PLC or touch panel display with the RS232C communication function at the machine side.

By continuously collecting data from the SUPER UNIT, it is possible to determine machining faults, diagnose machine failures, and use the data for predictive maintenance. For details on the communication procedure, refer to the *Communication/remote control function instruction manual*.

### 15.2 - Hybrid-win software

The software's graphical interface enables real-time monitoring of operating data, parameter reading and setting, and tracking of alarm and warning history.

The Hybrid-Win software is compatible with Microsoft Windows OS. To connect the Hybrid SUT to a PC, a cable connection kit is required. the kit can be ordered separately (see catalogue 96 501 SUTPC).

The Hybrid-Win software can be downloaded from the Duplomatic MS website, from the product page.

## 16 - ADDITIONAL DOCUMENTATION

*Instruction Manual PIM000657* provides instructions on commissioning, configuring the SUT and troubleshooting. Our Customers can download this manual both from the Reserved Area and from the Product Page in the Duplomatic MS website, using their own account.