

DS3B

SOLENOID ACTUATED DIRECTIONAL VALVE, DIRECT OPERATED SERIES 10



SUBPLATE MOUNTING ISO 4401-03

p max 350 bar
Q max 80 l/min

MOUNTING INTERFACE

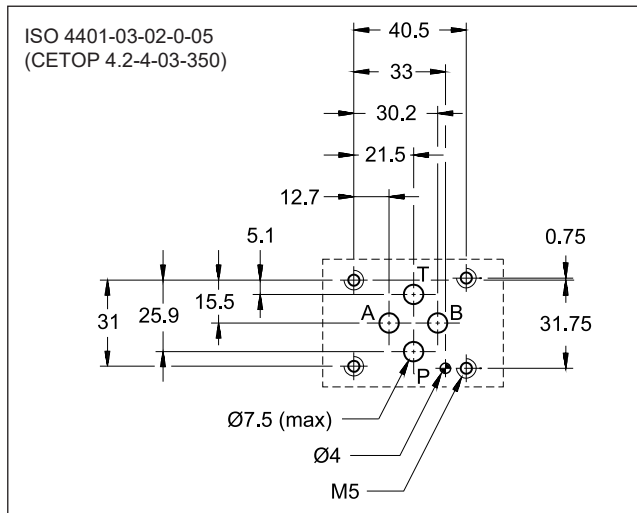

OPERATING PRINCIPLE

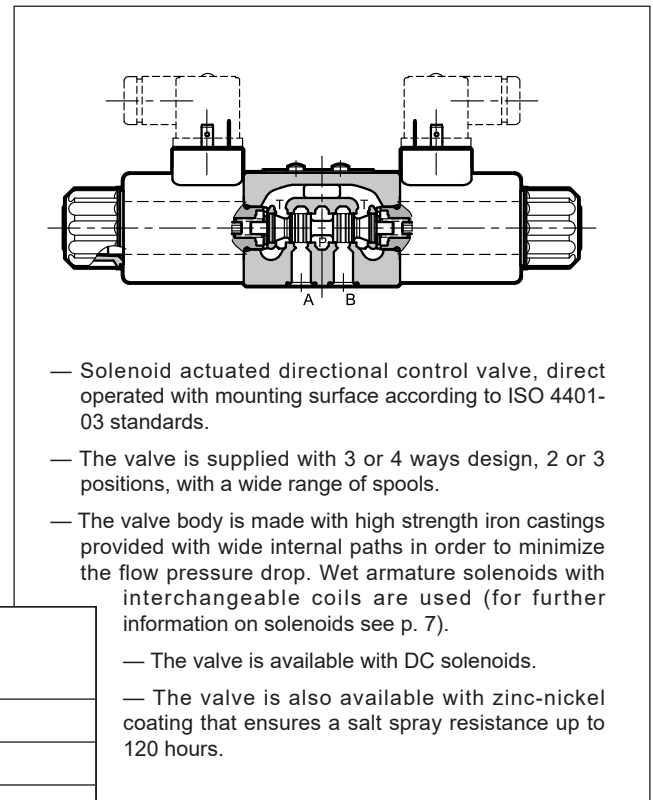

PERFORMANCES

(obtained with mineral oil with viscosity of 36 cSt at 50°C)

Maximum operating pressure: - P - A - B ports - T port	bar	350 210
Maximum flowrate	l/min	80
Pressure drops Δp -Q	see point 4	
Operating limits	see point 5	
Electrical features	see point 7	
Electrical connections	EN 175301-803 (ex DIN 43650)	
Ambient temperature range	°C	-20 / +50
Fluid temperature range	°C	-20 / +80
Fluid viscosity range	cSt	10 ÷ 400
Fluid contamination degree	according to ISO 4406:1999 class 20/18/15	
Recommended viscosity	cSt	25
Mass:		
single solenoid valve	kg	1.4
double solenoid valve	kg	2

1 - IDENTIFICATION CODE

	D	S	3	B	-		/	10	-		/	
--	----------	----------	----------	----------	---	--	---	-----------	---	--	---	--

Directional valve, solenoid operated

ISO 4401-03 size

Spool type (see point 3)

S* TA RK
SA* TB
SB* TA*
 TB*

Series: _____
(the overall and mounting dimensions remain unchanged from 10 to 19)

Seals: _____
N = NBR seals for mineral oil (standard)
V = FPM seals for special fluids

DC power supply _____
SD12 = 12 V
SD24 = 24 V
SD28 = 28 V
SD00 = valve without coils (see NOTE 1)

Option:
/ **W7** = Zinc-nickel surface treatment (see NOTE 2)
Omit if not required

Manual override:
omit for override integrated in the tube (standard) (see p. 12)
CM = manual override, boot protected
CK2 = push and twist override

Coil electrical connection (see p. 10):
K1 = plug for connector type EN 175301-803 (ex DIN 43650) (standard)
K2 = plug for connector type AMP JUNIOR (available on **D12** and **D24** coils only)
K7 = plug DEUTSCH DT04-2P for male connector type DEUTSCH DT06-2S

NOTE 1: Coils locking ring and related OR are supplied together with the valves.

NOTE 2: The standard valve is supplied with surface treatment of phosphating black.

The zinc-nickel finishing on the valve body makes the valve suitable to ensure a salt spray resistance up to **120** hours. (test operated according to UNI EN ISO 9227 standards and test evaluation operated according to UNI EN ISO 10289 standards).

2 - HYDRAULIC FLUIDS

Use mineral oil-based hydraulic fluids HL or HM type, according to ISO 6743-4. For these fluids, use NBR seals (code N). For fluids HFDR type (phosphate esters) use FPM seals (code V). For the use of other fluid types such as HFA, HFB, HFC, please consult our technical department. Using fluids at temperatures higher than 80 °C causes a faster degradation of the fluid and of the seals characteristics. The fluid must be preserved in its physical and chemical characteristics.

3 - SPOOL TYPE

Type S*:
2 solenoids - 3 positions
with spring centering

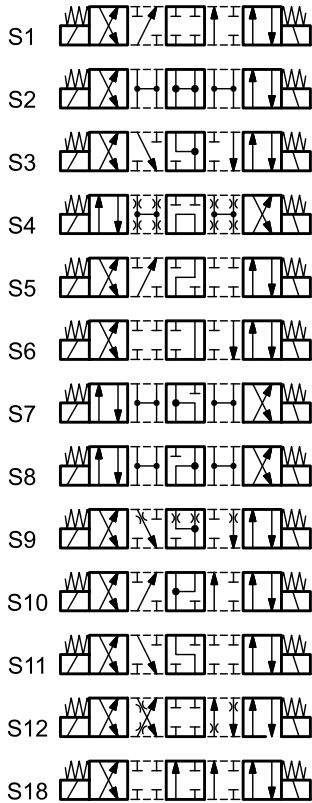
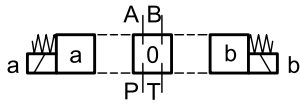

Type SA*:
1 solenoid side A
2 positions (central + external)
with spring centering

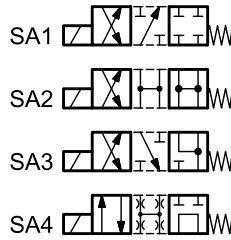
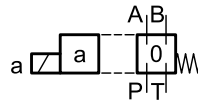

Type SB*:
1 solenoid side B
2 positions (central + external)
with spring centering

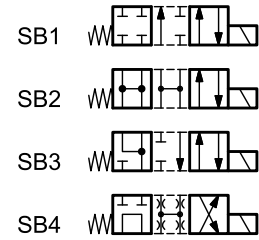
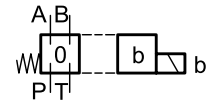

Type TA:
1 solenoid side A
2 external positions
with return spring

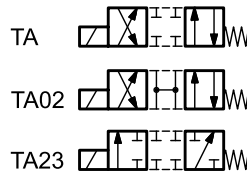
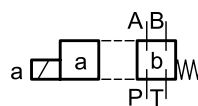

Type TB:
1 solenoid side B
2 external positions
with return spring

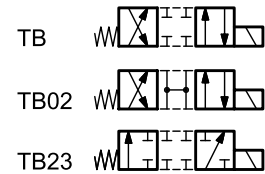
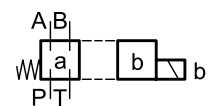

Type RK:
2 solenoids - 2 positions
with mechanical retention

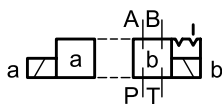



4 - PRESSURE DROPS Δp -Q

(obtained with viscosity 36 cSt at 50 °C)

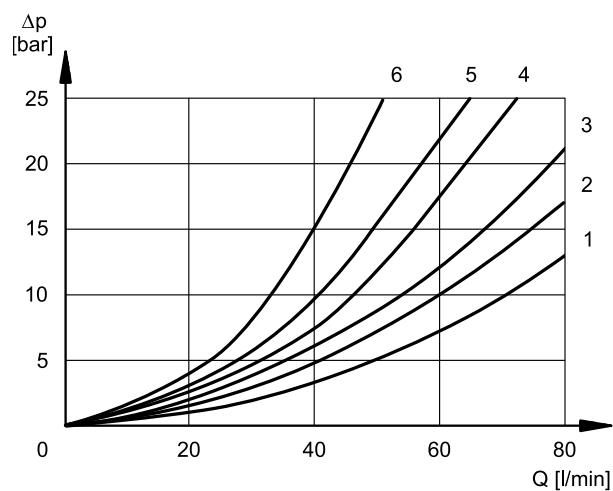

ENERGIZED POSITION

SPOOL TYPE	FLOW DIRECTION			
	P→A	P→B	A→T	B→T
	CURVES ON GRAPH			
S1, SA1, SB1	2	2	3	3
S2, SA2, SB2	1	1	3	3
S3, SA3, SB3	3	3	1	1
S4, SA4, SB4	5	5	5	5
S5	2	1	3	3
S6	2	2	3	1
S7, S8	4	5	5	5
S9	2	2	3	3
S10	1	3	1	3
S11	2	2	1	3
S12	2	2	3	3
S18	1	2	3	3
TA, TB	3	3	3	3
TA02, TB02	2	2	2	2
TA23, TB23	3	3		
RK	2	2	2	2

Please refer to curve no. 5 for pressure drops between A and B lines of the S10 spool when used in regenerative circuits.

DE-ENERGIZED POSITION

SPOOL TYPE	FLOW DIRECTION				
	P→A	P→B	A→T	B→T	P→T
	CURVES ON GRAPH				
S2, SA2, SB2					2
S3, SA3, SB3			3	3	
S4, SA4, SB4					3
S5		4			
S6				3	
S7, S8			6	6	3
S10	3	3			
S11			3		
S18	4				

5 - SWITCHING TIMES

The values indicated are obtained according to ISO 6403 standard, with mineral oil viscosity 36 cSt at 50°C.

TIMES [ms]	
ENERGIZING	DE-ENERGIZING
25 ÷ 75	15 ÷ 25

6 - OPERATING LIMITS

The curves define the flow rate operating fields according to the valve pressure of the different versions. The values have been obtained according to ISO 6403 norm with solenoids at rated temperature and supplied with voltage equal to 90% of the nominal voltage. The value have been obtained with mineral oil, viscosity 36 cSt, temperature 50 °C and filtration according to ISO 4406:1999 class 18/16/13.

The limits have been verified with standard 4-port valve. Performance can be considerably reduced if a 4-port valve is used as 3-port, with port A or B plugged or without flow.

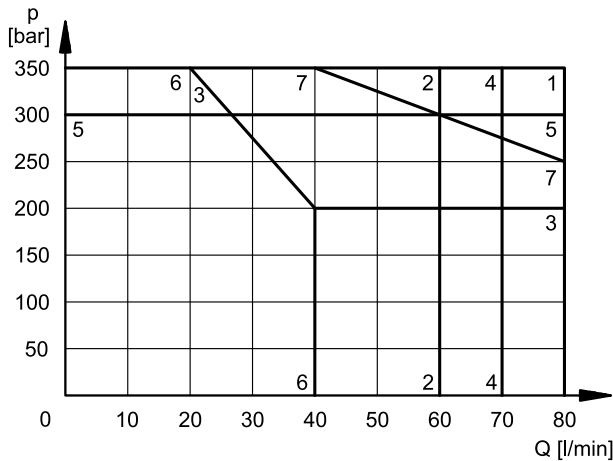

SPOOL	CURVE	
	P→A	P→B
S1, SA1, SB1	1	1
S2, SA2, SB2	2	2
S3, SA3, SB3	3	3
S4, SA4, SB4	4	4
S5	5	5
S6	4	6
S7	4	4
S8	4	4
S9	1	1
S10	1	1
S11	4	6
S12	1	1
S18	5	5

SPOOL	CURVE	
	P→A	P→B
TA, TB	1	1
TA02, TB02	1	1
TA23, TB23	2	2
RK	7	7

7 - ELECTRICAL FEATURES

7.1 - Solenoids

These are essentially made up of two parts: tube and coil. The tube is threaded into the valve body and includes the armature that moves immersed in oil, without wear. The inner part, in contact with the oil in the return line, ensures heat dissipation. The coil is fastened to the tube by a threaded ring, and can be rotated 360°, to suit the available space.

Protection from atmospheric agents IEC 60529

The IP protection degree is guaranteed only with both valve and connectors of an equivalent IP degree, correctly connected and installed.

electric connection	electric connection protection	whole valve protection
K1 EN 175301-803 (ex DIN 43650)	IP65	IP65
K2 AMP JUNIOR	IP65	
K7 DEUTSCH DT04 male	IP65/67	

SUPPLY VOLTAGE FLUCTUATION	± 10% Vnom
MAX SWITCH ON FREQUENCY	18.000 ins/hr
DUTY CYCLE	100%
ELECTROMAGNETIC COMPATIBILITY (EMC) (NOTE)	In compliance with 2014/30/EU
LOW VOLTAGE	In compliance with 2014/35/EU
CLASS OF PROTECTION Coil insulation (VDE 0580) Impregnation: DC valve	class H class F

NOTE: In order to further reduce the emissions, with DC supply, use of type H connectors is recommended. These prevent voltage peaks on opening of the coil supply electrical circuit (see cat. 49 000).

7.2 - Current and absorbed power

The table shows current and power consumption values of the DC coils.

Coils for direct current (values ± 10%)

	Nominal voltage [V]	Resistance at 20°C [Ω]	Current consumpt. [A]	Power consumpt. [W]	Coil code		
					K1	K2	K7
SD12	12	4.5	2.67	32	1903780	1904190	1904050
SD24	24	18.6	1.29	31	1903781	1904191	1904051
SD28	28	25.3	1.07	31	1903782	-	1904052

8 - OVERALL AND MOUNTING DIMENSIONS

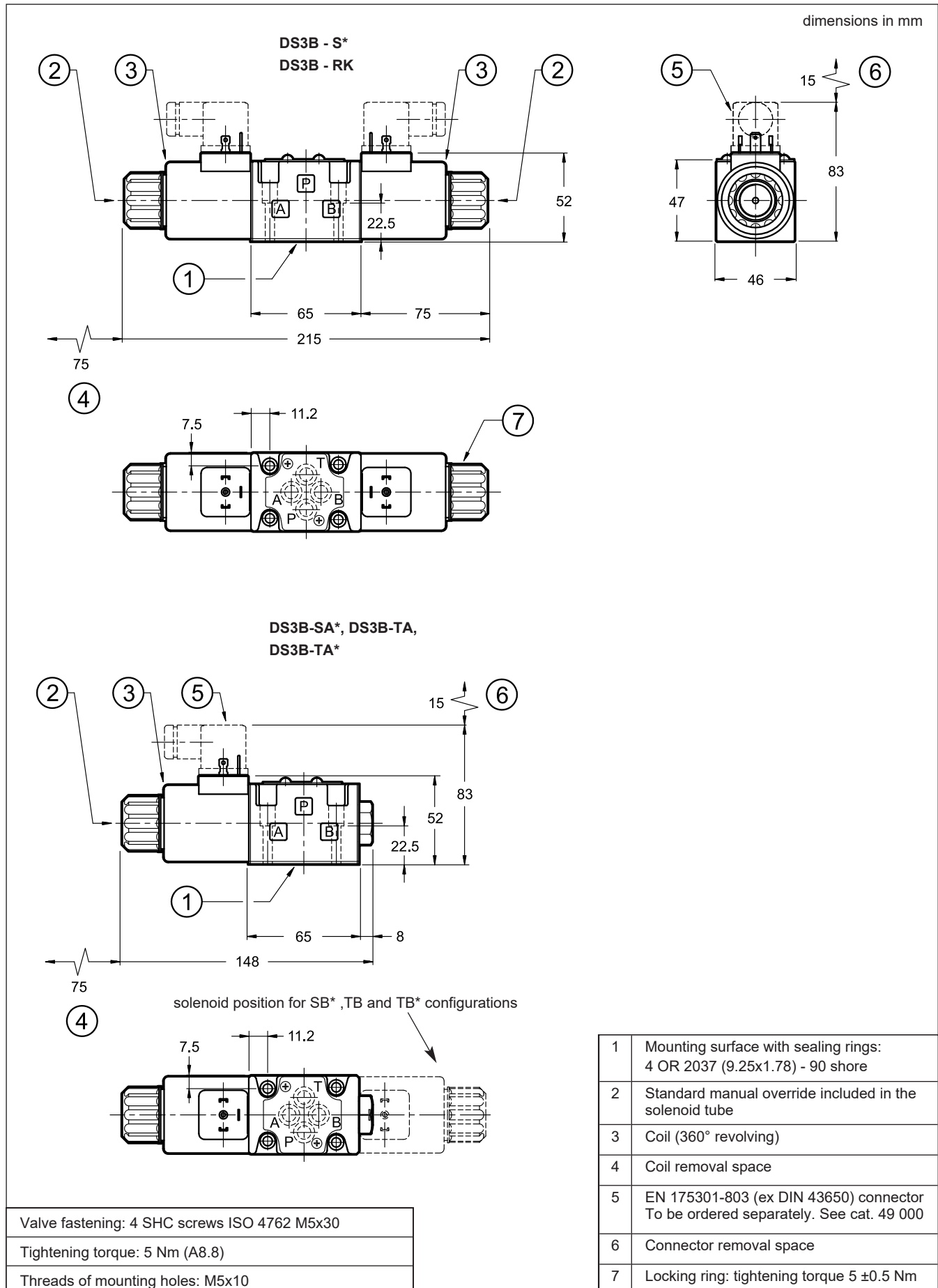

9 - INSTALLATION

Configurations with centering and return springs can be mounted in any position; type RK valves - without springs and with mechanical detent - must be mounted with the longitudinal axis horizontal.

Valve fixing takes place by means of screws or tie rods, with the valve mounted on a lapped surface, with values of planarity and smoothness that are equal to or better than those indicated in the drawing. If the minimum values of planarity and/or smoothness are not met, fluid leakages between valve and mounting surface can easily occur.

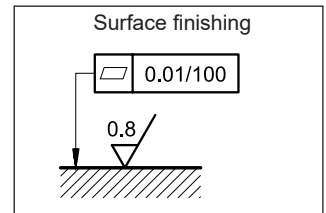

10 - ELECTRIC CONNECTIONS

connection for EN 175301-803
(ex DIN 43650) connector
code **K1 (standard)**

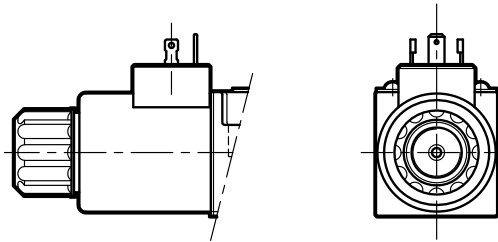

connection for AMP JUNIOR
connector
code **K2**



connection for
DEUTSCH DT06-2S male connector
code **K7**



11 - ELECTRIC CONNECTORS

Solenoid operated valves are delivered without connectors. Connectors type EN 175301-803 (ex DIN 43650) for K1 connections can be ordered separately. See catalogue 49 000.

12 - MANUAL OVERRIDES

12.1 - CM-DS3/11 manual override, boot protected

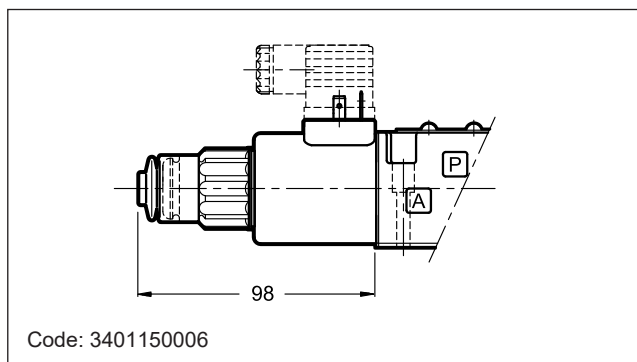

12.2 - CK2-DS3B/10 push and twist manual override

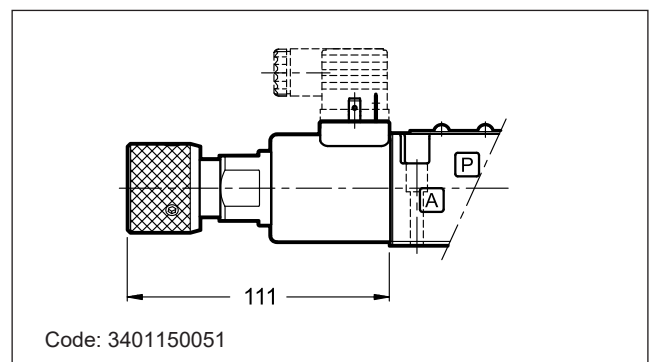

13 - PORT RESTRICTORS

Port restrictors are recommended if flow variations which exceed the valve performance limit during the switching processes occur, or for circuit dampening.

Port restrictor plugs can be ordered separately with the part numbers shown at left.

Ø (mm)	part numb.	Ø (mm)	part numb.
blank	0144162	1.2	0144035
0.6	0144163	1.5	0144036
0.8	0144033	1.8	0144164
1	0144034	2	0144165

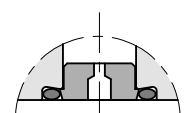

14 - SPARE PARTS

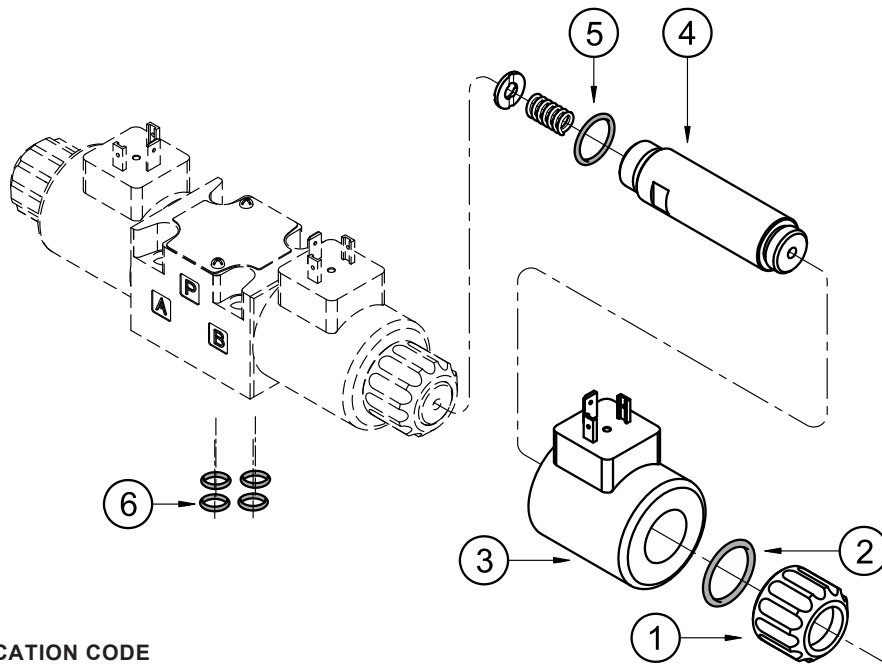

COILS IDENTIFICATION CODE

C 22S3 - /

Supply voltage
SD12 = 12 V
SD24 = 24 V
SD28 = 28 V

Series no.:
12 = for K1
13 = for K2 and K7

Coil electrical connection
K1 = plug for connector EN 175301-803 (ex DIN 43650) (**standard**)
K2 = plug for connector type AMP JUNIOR (available on **D12** and **D24** coils only)
K7 = plug DEUTSCH DT04-2P, for male connector type DEUTSCH DT06-2S.

1	Coil locking ring with seal included cod. 0119412 Tightening torque 5 ±0.5 Nm
2	ORM type 0220-20 (22x2) - 70 Shore
3	Coil (see identification code)
4	Solenoid tube for standard version: TDS22-DS3/10N (NBR seals) TDS22-DS3/10V (FPM seals) NOTE: OR n°5 included
5	OR type 2062 (15.6x1.78) - 70 Shore
6	4 OR type 2037 (9.25x1.78) - 90 Shore

SEALS KIT

The codes include the O-Ring n° 2, 5, and 6

Cod. **1985406** NBR seals
 Cod. **1985410** FPM (viton) seals

NOTE: You can also order coils using the coil codes at point 7.2

15 - SUBPLATES

(see catalogue 51 000)

Type PMMD-AI3G with rear ports 3/8" BSP

Type PMMD-AL3G with side ports 3/8" BSP

DIPLOMATIC
 MOTION SOLUTIONS
 a member of **DAIKIN** group

DIPLOMATIC MS Spa

via Mario Re Depaolini, 24 | 20015 Parabiago (MI) | Italy

T +39 0331 895111 | E vendite.ita@diplomatic.com | sales.exp@diplomatic.com

diplomaticmotionsolutions.com