



# EWM-SS-DAD

CARD FOR  
SYNCHRONIZATION CONTROL  
IN SYSTEMS WITH UP TO 9 AXES  
WITH CAN COMMUNICATION  
SERIES 20

**RAIL MOUNTING TYPE:  
DIN EN 50022**

### OPERATING PRINCIPLE

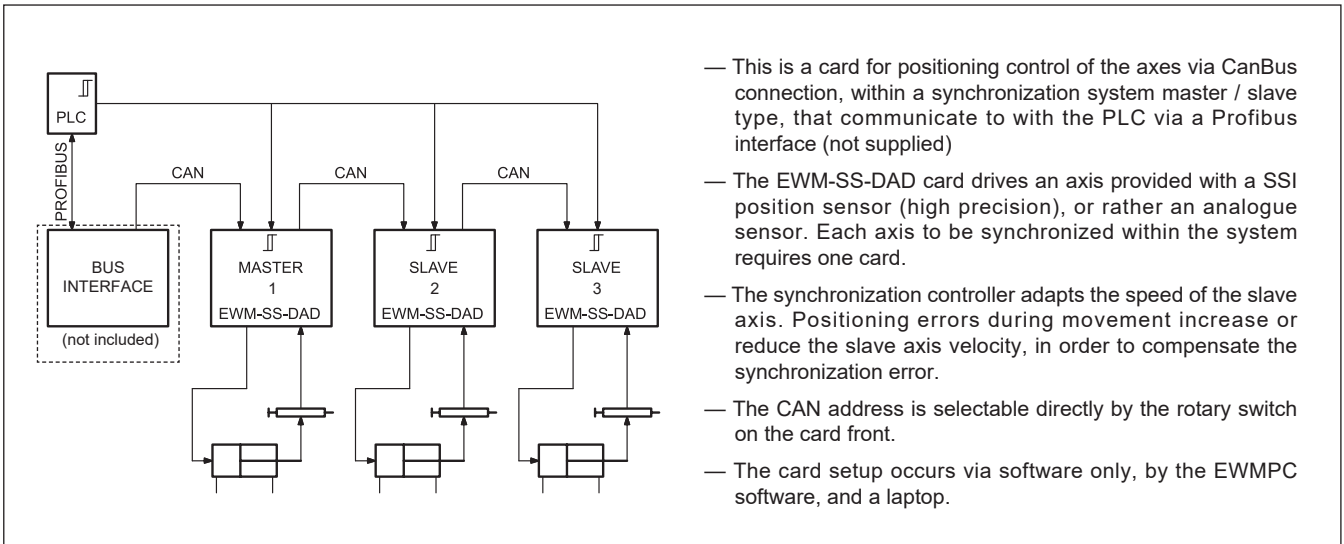

### TECHNICAL CHARACTERISTICS

Power supply	V DC	24 ÷ 30 ripple included - external fuse 1.0 A
Current consumption	mA	< 350 + sensor power consumption
Command value and speed input value		via BUS (via CAN to the cards or via Profibus-CAN interface module)
Feedback value	SSI V mA	digital sensor with SSI interface 0 ÷ 10 (R <sub>I</sub> = 25 kohm) 4 ÷ 20 (R <sub>I</sub> = 240 ohm)
Output value - E0 version - E1 version	V mA	±10 differential (max load 5 mA) 4 ÷ 20 (max load 390 ohm )
Position accuracy		± 2 bits of digital sensor resolution
Sample time	ms	2 ÷ 5
Serial interface		USB-B 2.0 - CANBus
Electromagnetic compatibility (EMC)		Emissions EN 61000-6-3:2005 Immunity EN 61000-6-2:2002
Housing material		thermoplastic polyamide PA6.6; combustibility class V0 (UL94)
Housing dimensions	mm	114 x 99(h) x 46(w)
Connectors		8x4 poles screw terminals - PE direct via DIN rail - USB
Operating temperature range	°C	-10 / +50
Protection degree		IP20

### 1 - IDENTIFICATION CODE

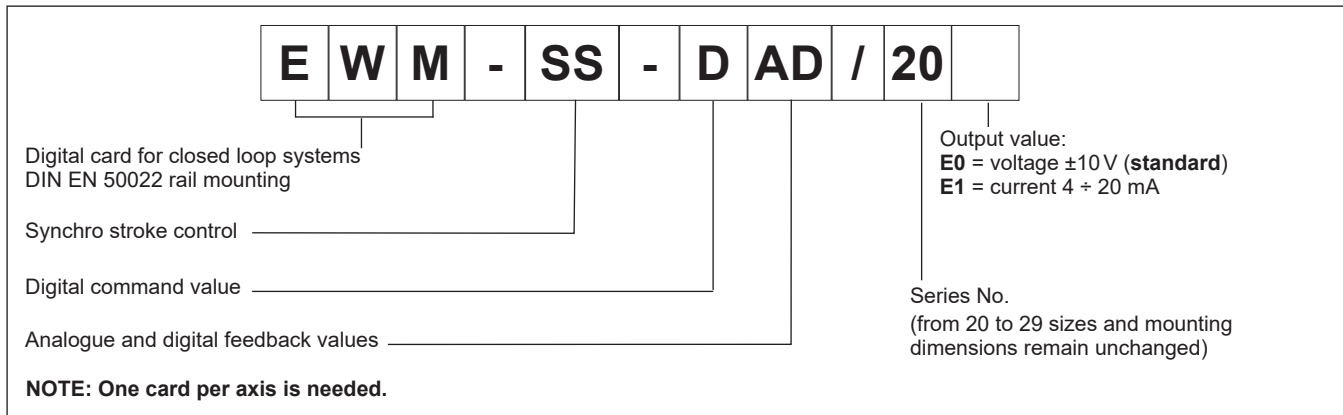

### 2 - FEATURES OVERVIEW

#### Controller Functions

- Synchronized or independent positioning control in closed loop, within a synchronous system with up to 9 axes
- 32 bit command position, 16 bit speed parameter, on loop control byte and status byte via fieldbus
- Fine positioning - 1  $\mu$ m resolution
- 2 methods for positioning control:
  - SDD – Stroke Depending Deceleration - time-optimal positioning structure with very high stability
  - NC – Numerically Controlled - To follow the position profile
- 2 synchronization methods:
  - Master-slave
  - Average value controller
- Data for lengths in mm
- For digital SSI sensor
- As alternative, the card can be set via software for operate with analogue position sensor.
- Analogue sensor scalable via software
- Gain adjustment made via software with independent parameters for SDD and NC modes
- PT1 compensator for optimized control of hydraulic drives
- Safe and error-free data transmission
- Manual mode available via fieldbus.

#### Adaptation of the valve characteristic curve

- CTRL function to adapt the braking characteristics to positive and zero overlapped proportional valves
- Advanced deadband compensation: non-linearity compensation by a double-gain characteristics

#### Monitoring functions

- In-position error
- Cable break, in-pressure error and fault of feedback sensors
- 2 Digital output to read the status

#### Other characteristics

- Output in voltage or current, to be set via software
- Card setup is made via software, USB-B socket on the module.

### 3 - FUNCTIONAL SPECIFICATIONS

#### 3.1 - Power supply

This card is designed for 24 V DC of a power supply. This power supply must correspond to the existing EMC standards. All inductiveness at the same power supply (relays, valves) must be provided with an over voltage protection (varistors, freewheeling diodes).

It is recommended to use a regulated power supply (linear or switching mode) for the card supply and for the sensors.

#### 3.2 - Electrical protections

All inputs and outputs are protected with suppressor diodes and RC-filters against transient overshoots.

#### 3.3 - Digital Input (ENABLE)

The card accepts digital input. The digital input must have a voltage from 12 to 24 V; Low level:  $< 2$  V, high level  $> 10$  V. Input resistance 25 kohm. See the block diagram at point 4 for the electric connections.

#### 3.4 - Reference signal

The reference signals run via fieldbus, through a Profibus interface module.

#### 3.5 - Position feedback values

The card accepts a digital feedback input from a sensor with any SSI interface with RS422 specifications. Bit, code and resolution are settable via software.

Use SSI sensors with the same resolution (max 1  $\mu$ m)

Eventually, an analogue input could be used as feedback. The card accepts a  $0 \div 10$  V ( $R_i$  33 kohm) or  $4 \div 20$  mA ( $R_i$  = 240 ohm).

The analogue signal resolution is of 0,01 % oversampling included.



Using analogue sensors, the SSI parameters in the software assume default preset values that the user must do not change.

#### 3.6 - Output values

E0 version: output voltage  $0 \pm 10$  V (max load 5 mA).

E1 version: output current  $4 \div 20$  mA. (max load 390 ohm)

#### 3.7 - Digital output signals

Two digital output signals are available (INPOS and Ready) which are also displayed via the LEDs on the front panel.

Low level  $< 2$  V, High level  $> 10$  V, max power supply 50 mA with 250 ohm load.

## 4 - WIRING DIAGRAM FOR EWM-SS-DAD AND FIELDBUS MODULE

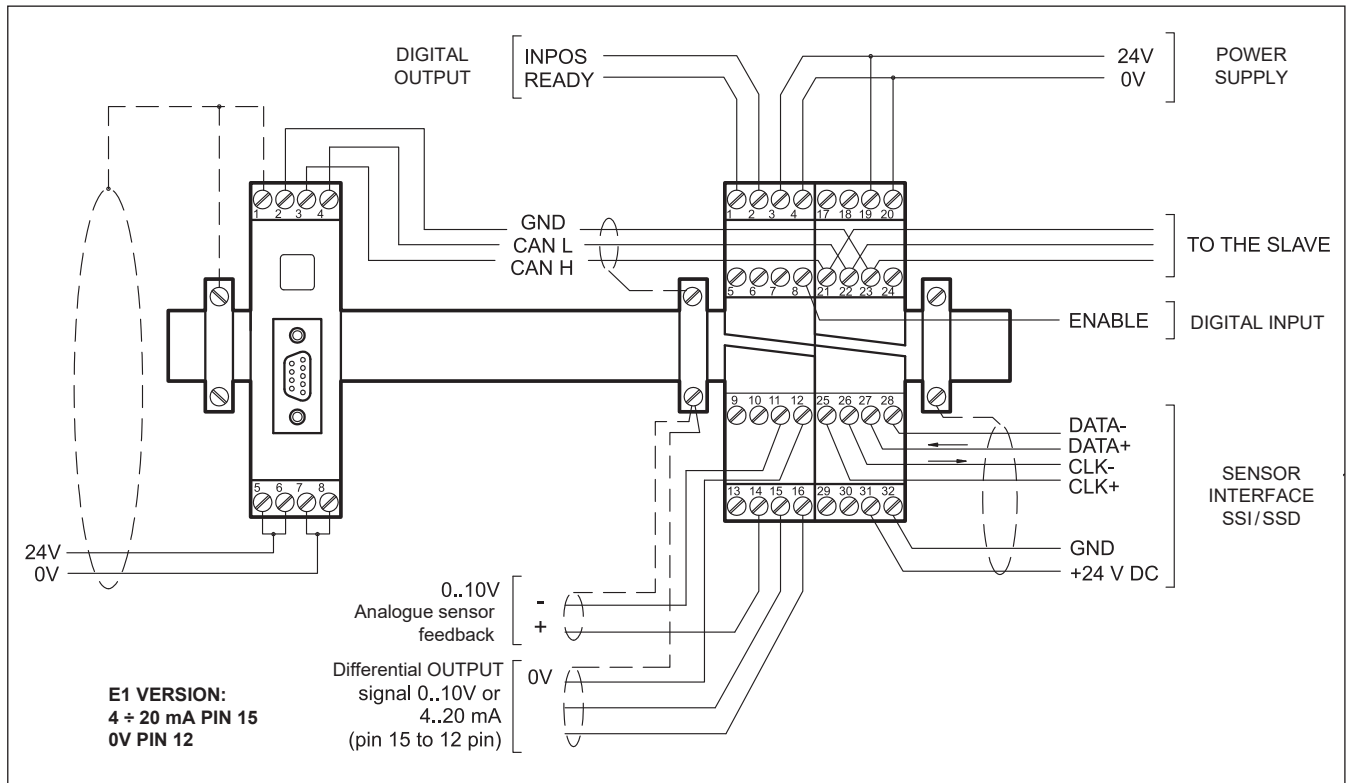

### DIGITAL INPUT AND OUTPUT

- PIN 1** READY output - green LED  
General operativeness. ENABLE command (is active and there is no sensor error (by use of 4 ÷ 20 mA sensors). It's on when ENABLE (PIN 8 and enable via fieldbus) is active and there are no sensor errors.
- PIN 2** STATUS output - yellow LED  
STATUS is active when the axis is within the values range defined by INPOS set, for positioning or for synchronisation.
- PIN 8** ENABLE input  
This digital input signal enables the application. If no errors are detected the READY signal is active. With no command the target position is set to actual position. With command, the axis is ready to operate and the analogue output is powered to the actuator, whose movement is closed loop controlled.

### ANALOGUE SIGNALS

- PIN 14** Analogue feedback value (X), range 0 ÷ 100% corresponds to 0 ÷ 10V or 4 ÷ 20 mA
- PIN 15/16** Differential output (U)  
E0 : ±100% corresponds to ± 10V differential voltage, E1 : current output ±100% corresponds to 4 ÷ 20 mA (PIN 15 to PIN 12)

### LOCAL CANBUS

- PIN 21..23** CAN LO, CAN HI, and GND
- PIN 24** CANbus termination  
a bridge to pin 22 is required inside the master module and inside the last module of the chain.

### 5 - INSTALLATION

It is recommended to use cable sections of 0.75 mm<sup>2</sup>, up to 20 m length and of 1.00 mm<sup>2</sup> up to 40 m length, for power and solenoid supply.

For other connections use cables with a shielded jacket, connected to GND only on the card side.

**NOTE :** To observe EMC requirements it is important that the control unit electrical connection is in strict compliance with the wiring diagram.

As a general rule, the valve and the electronic unit connection wires must be kept as far as possible from interference sources (e.g. power wires, electric motors, inverters and electrical switches).

Complete protection of the connection wires can be requested in environments with critical electromagnetic interferences.

#### 5.1 - Start-up

The module must be mounted and wired with attentions to EMC requirements. A star orientated ground connection should be used when other power consumers are sharing the same power supply. Following points have to be taken in account for wiring:

- Signal cable and power cable have to be wired separately.
- Analogue signal cables must be shielded.
- Other cables should be shielded in case of strong electrical disturbance (power relays, frequency controlled power driver) or at cable lengths > 3m.

With high frequency EMI inexpensive ferrite elements can be used.

Take in account a separation between the power part (and power cables) and signal part when arrange the areas inside the electrical cabinet. Experience shows us that the area next to the PLC (24 V area) is suitable.

Low impedance between PE "protected earth" and DIN-Rail should be used. Transient interference voltages at the terminals are discharged via DIN-Rail to the local PE. The screens have to be connected directly next to the module via PE terminals.

The power supply should be carried out voltage regulated (i. e. PWM controlled). The low impedance of controlled power supplies facilitates improved interference damping, therefore the signal resolution will be increased.

Switched inductance (relays and solenoids) operating from the same power supply has to be damped by surge protection elements directly by the inductance.

#### 5.2 - ProfiBUS / CANbus interface

Pins 21 to 23 are reserved to the CAN connection between the EWM-SS-DAD cards. As option, it is possible to connect a Profibus / CAN interface module connected to terminals 21-22-23 of the EWM-SS-DAD module set as 'master'.

Please refer to the fieldbus documentation for further details.

#### 5.3 - EWM-SS-DAD - CAN connection

The CAN connection is wired on all modules in parallel. The terminating resistors have to be activated in the EWM-SS-DAD at the first and last module. Termination is enabled by a bridge between pin 22 and pin 24.



Start the addressing of the EWM-SS-DAD from the number 1, that set the card as MASTER, using the rotary switch on the front panel of the card (use a screwdriver or a small knob of appropriate size).

The MASTER module drives the main axis and takes over the communication with the fieldbus interface module.

The other addresses (2 to 9) set the card as SLAVE.

Upon delivery, the rotary switch is set to zero (no address); you must configure the addressing on each card in the series, depending on the number of axes to be synchronized (see example below).

#### 5.4 - Wiring for 4-axes synchronization

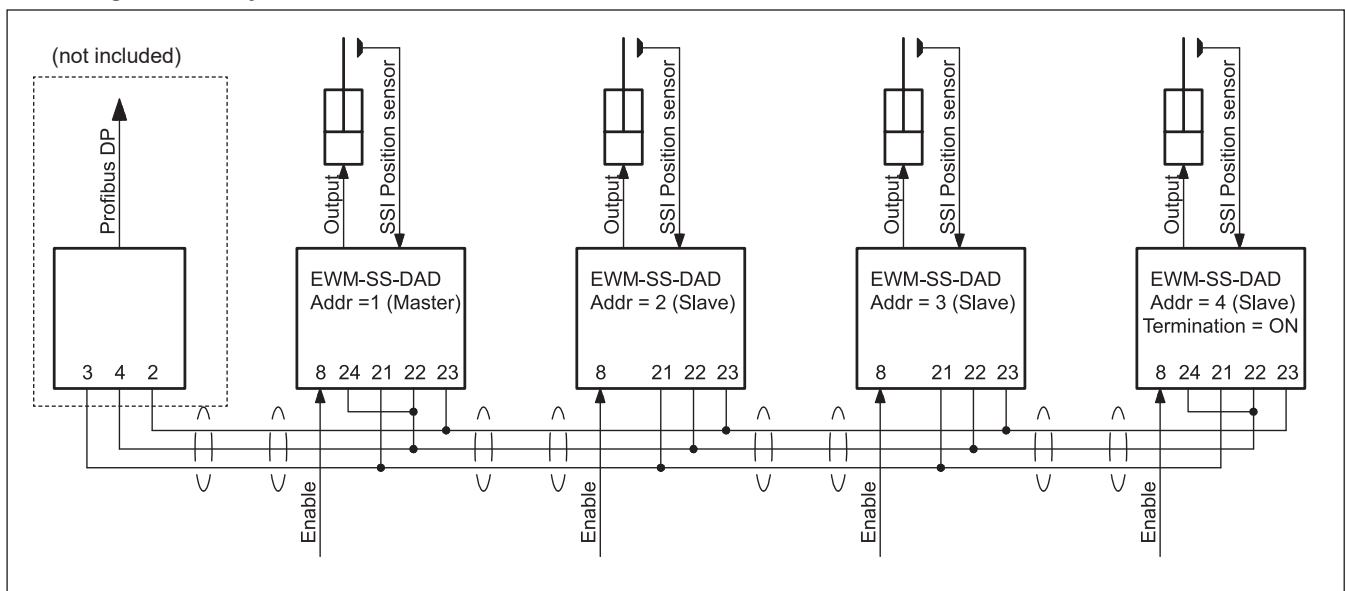

### 6 - DEVICE SETUP

Card set-up is possible via software only.

#### 6.1 - Software EWM20\_SmartManager

The software EWM20\_SmartManager can be easily downloaded from the Duplomatic MS website in the section SOFTWARE DOWNLOAD.

To connect the card to a PC or notebook, a standard USB 2.0 cable A – B (standard USB printer cable) is necessary.

Once connected, the software automatically recognises the card model and shows a table with available commands, their parameters, the default setting, the measuring unit and a brief explanation for correct set-up.

Some functions like baud rate setting, remote control mode, saving of process data for later evaluation are used to speed up the installation procedure.

The software is optimized for Microsoft OS Windows 10 and it is still compliant with Windows 7.

#### 6.2 - Parameters table

The parameters table is available in English language.

Once connected, the software recognises the card model automatically, then it shows a table with all the available commands, their parameters, default settings, measuring units and a brief explanation for correct set-up.

The hardware setup must be identical for all the axes. Design with symmetrical structures is strongly recommended.

**For a complete list of parameters and their settings please refer to the Technical Manual 89460 ETM.**

### 7 - MAIN FEATURES

The EWM-SS-DAD is a card for position control of two axes in synchronous mode. Communication with the PLC takes place via an interface bus not covered by this documentation.

We recommend checking the input signals and the pre-parameterization of the cards before switch on the entire system.

Two methods for positioning are available:

**SDD - stroke depending deceleration** - means the control gain will be adjusted. This is a time-optimal positioning structure with very high stability.

**NC mode** - the position value is generated from the following error.

The actuator position is measured by a transducer and compared with a specified target position. The target position and speed are set by fieldbus.

The positioning accuracy will almost be limited by the resolution of the transducer and by the size of the hydraulic valve. Therefore, the correct valve selection is the most important point to be evaluated during the planning stage, being careful on how to balance positioning time and system accuracy.

#### 7.1 - Sequence of the positioning

The positioning process is controlled by switching the digital inputs.

Once enabled (ENABLE input changeover), the axis must remain in the current position (ie the current position is accepted as the target position). Instead, if the axis moves to one of the final positions, the polarity setting (POL parameter) is probably wrong.

The READY output indicates that the unit is ready to operate. The VEL parameter [variable from 1 to 20000 and expressed in mm/sec] limits the value of the movement speed sent via the fieldbus.

A active START signal causes the requested position sent via the fieldbus to be accepted and the axis moves to the target position.

The digital INPOS output shows when the axis reaches the target position: the difference between the position requested by the

control signal and the actual position detected by the position transducer must be lower than the INPOS value parameterized in the EWM card (range 0...5000, expressed in 0.01 mm).

Axes synchronization is achieved by activating the GB ACTIVE input. If the application allows to start the axis once, it is advisable to optimize the axes individually and to activate the synchronous control only afterwards.

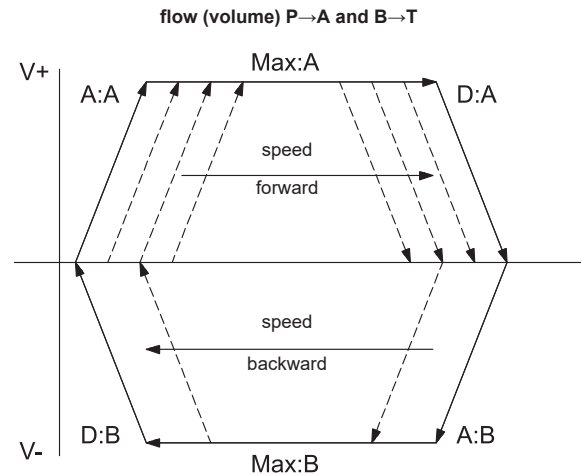

#### 7.2 - Adaptation of the braking characteristic to the valve type (CTRL).

The deceleration characteristic is set with this parameter. The SQRT function should be applied to positive overlapped proportional valves. The non-linear flow characteristic of these valves is linearized by the SQRT function.

The LIN or SQRT1 function should be applied to zero-lapped valves (control valves and servo valves) regardless of the application. The progressive characteristic of the SQRT1 function has better positioning accuracy but can also lead to longer positioning times in individual cases.

Different parameters available for each axes.

**LIN:** Linear deceleration characteristic (gain is increased by a factor of 1).

**SQRT1:** Root function for braking curve calculation. The gain is increased by a factor of 3 (in the target position). This is the default setting.

**SQRT2:** Root function for braking curve calculation. The gain is increased by a factor of 5 (in the target position). This setting should only be used with a significantly progressive flow through the valve.

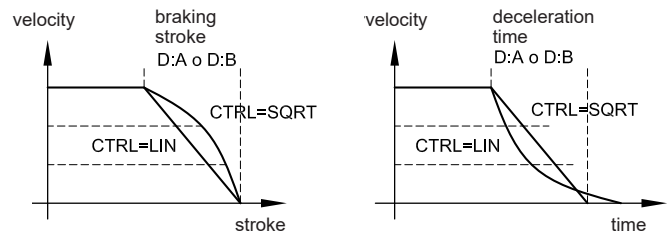

### 7.3 - Adaptation of the output signal to the valve characteristic (TRIGGER)

With TRIGGER command, the output signal is adapted to the valve characteristics.

The positioning controllers have a double-gain characteristic curve instead of a typical overlapped jump. The advantage is a better and more stable positioning behaviour. With this compensation, non-linear volume flow characteristic curves can be adjusted too.

If there exist also possibilities for adjustments at the valve or at the valve electronics, it has to be guaranteed, that the adjustment has to be carried out either at the power amplifier or at the positioning module.

If the deadband compensation value (MIN) is set too high, it influences the minimal velocity which cannot be adjusted any longer.

In extreme cases this can cause oscillations around the closed loop controlled position.

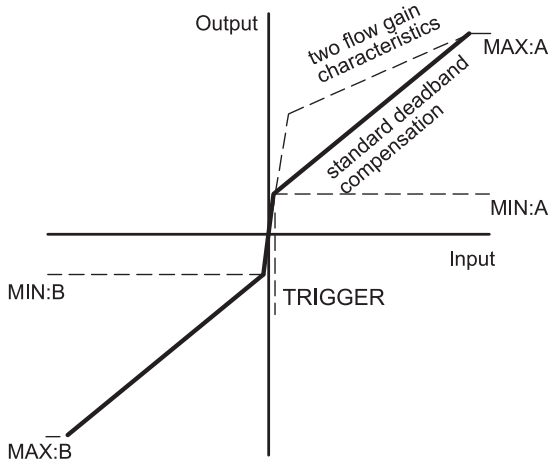

### 7.4 - Fieldbus interface communication

The fieldbus module controls the EWM-SS-DAD card by sending 24 bytes of data, which contain also control command data (two 16-bit control words, unsigned), command position data (a 32-bit double word, unsigned) and the speed control data (a 16-bit word unsigned).

By connecting to the terminals of the Master card only, the EWM-SS-DADs return to the fieldbus interface a further 24 bytes of data that contain also the card status data (two 16-bit status words unsigned each), the current nominal position data (a double word 32-bit unsigned) and the current real position of the axes.

These data can be examined by connecting the EWMPC software to the USB-B port of the master card, and typing the ST command.

**Please refer to 89460 ETM technical manual for further information.**



## 8 - EWM-SS-DAD - CARD BLOCK DIAGRAM (E0 VERSION)

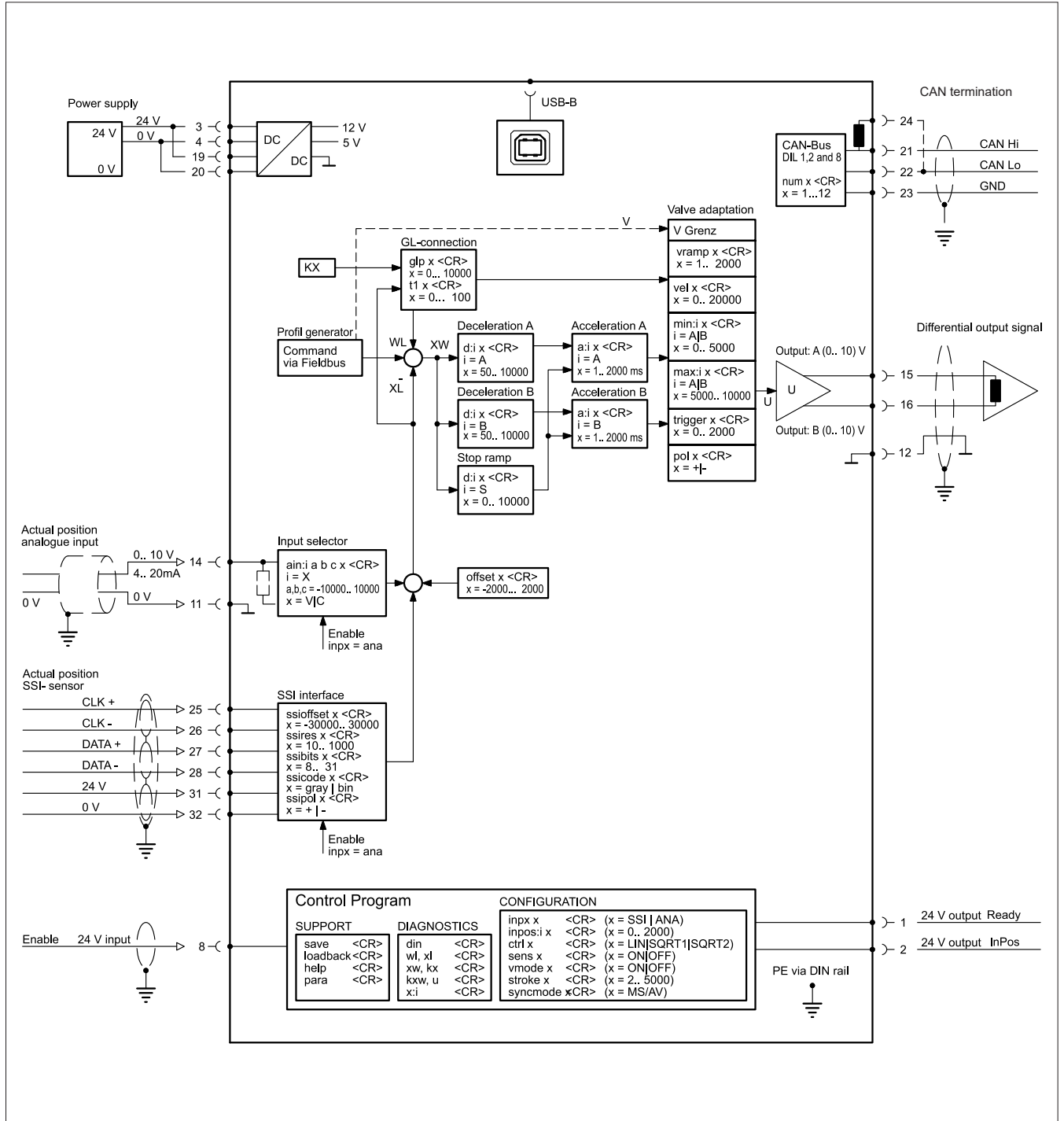

### 8.1 - Output Signal - E1 Version

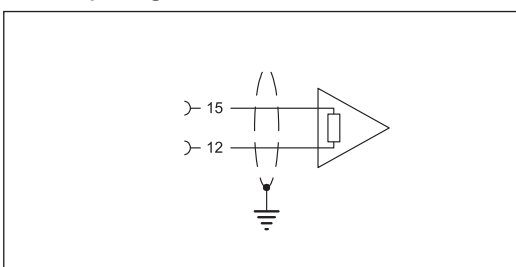

## 9 - OVERALL AND MOUNTING DIMENSIONS

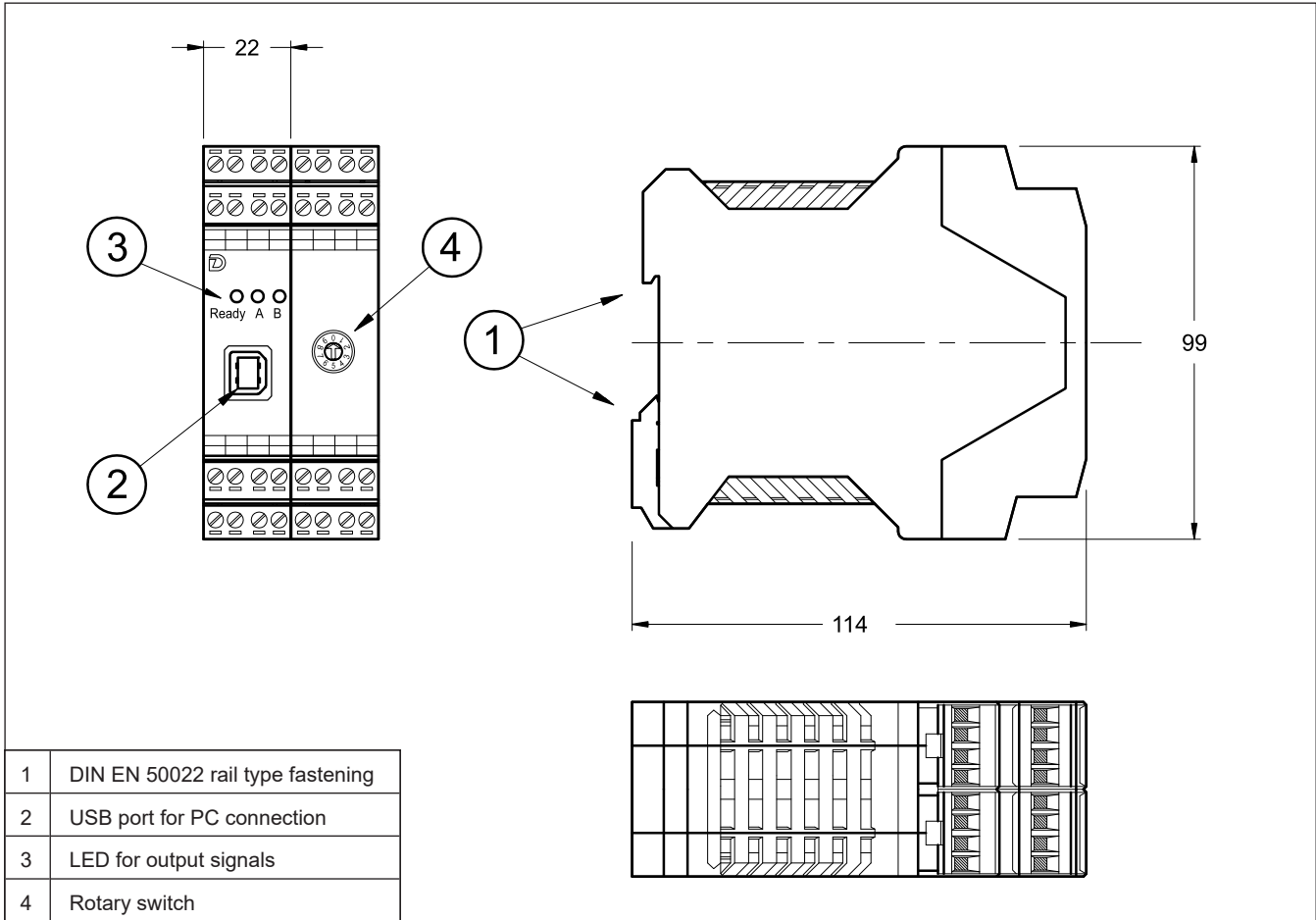

## 10 - ELECTRONIC ACCESSORY UNITS

### 10.1 - EWM-BUS-DD - Profibus/CAN interface

This coupler allows the data exchange between a CAN network and PROFIBUS PLC, through a built-in interface inside one housing.

The EWM-BUS-DD, combined with EWM-SS-DAD cards, allows to design synchronization systems with CAN communication on the axes network side, and with PROFIBUS communication on PLC side.

The EWM-BUS-DD can be ordered with code: **3809460001**