



EWM-PQ-AA

DIGITAL CARD FOR PRESSURE/FLOW CONTROL IN CLOSED LOOP SYSTEMS SERIES 20

**RAIL MOUNTING TYPE:
DIN EN 50022**

OPERATING PRINCIPLE

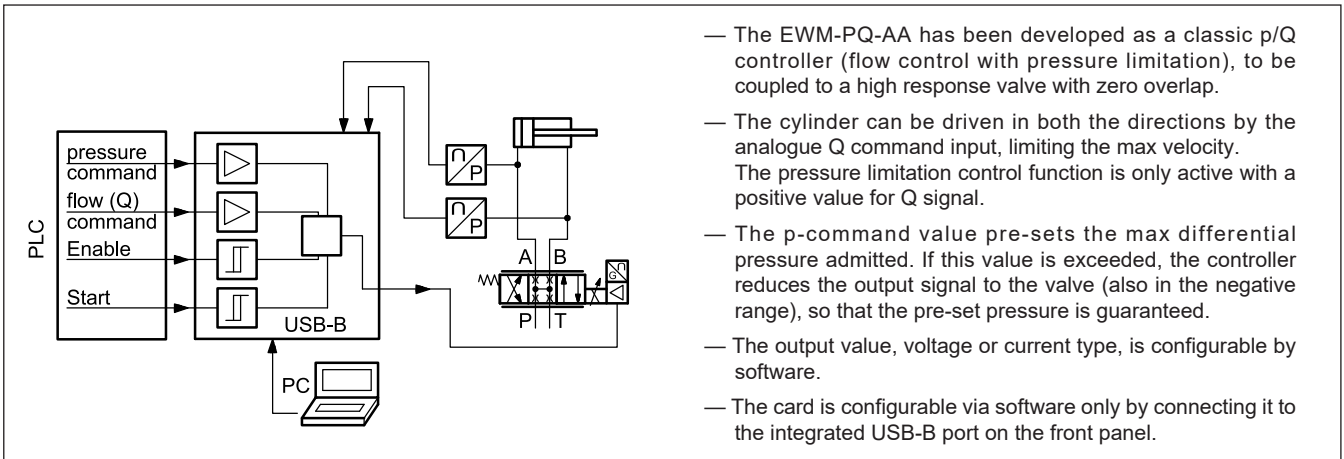

TECHNICAL CHARACTERISTICS

Power supply	V DC	12 ÷ 30 ripple included
Fuse, external		1A medium time lag
Current consumption	mA	<100
Pressure command (p)	mA V	4 ÷ 20 (RI = 240 ohm) 0 ÷ 10 (RI = 25 kohm)
Flow command (Q)	mA V	4 ÷ 20 (RI = 240 ohm) ±10 (RI = 90 kohm)
Feedback values	mA V	4 ÷ 20 (RI = 240 ohm) 0 ÷ 10 (RI = 25 kohm)
Sensor resolution	%	0,003 incl. oversampling
Output values	V mA	± 10 (max load 10 mA 2 kohm) differential 4 ÷ 20 (max load 390 ohm)
Sample time	ms	1
Interface		USB-B 2.0
Electromagnetic compatibility (EMC) 2014/30/EU		Immunity EN 61000-6-2: 8/2005 Emissions EN 61000-6-4: 6/2007; A1:2011
Housing material		thermoplastic polyamide PA6.6 - combustibility class V0 (UL94)
Housing dimensions	mm	120(d) x 99(h) x 23(w)
Connections		USB-B (2.0) - 4x poles screw terminals - PE direct via DIN rail
Operating temperature range	°C	-20 / +60
Protection degree		IP 20

1 - IDENTIFICATION CODE

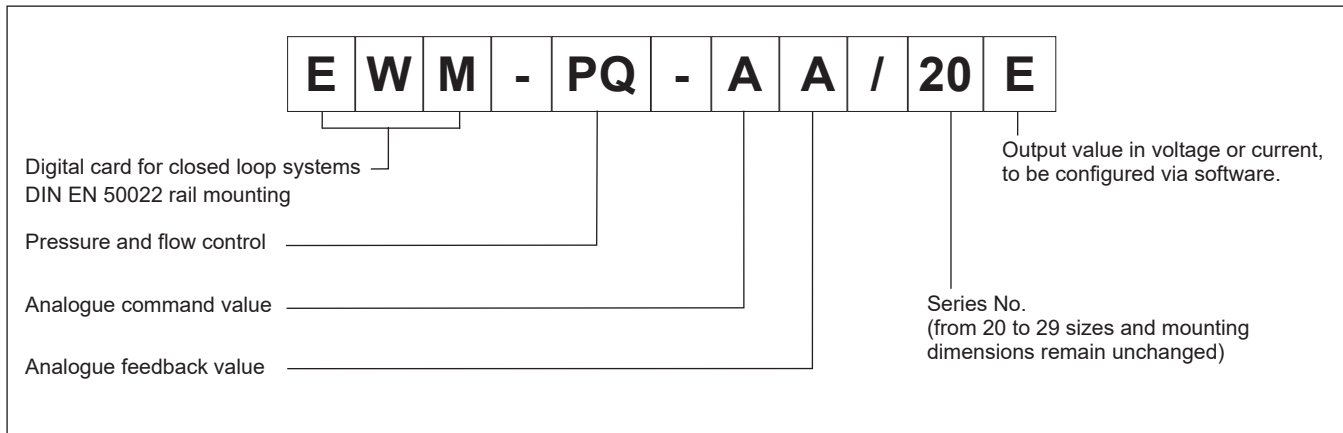

2 - FEATURES OVERVIEW

Controller Functions

- Analogue Q- and p-command signals
- Classical p/Q controller with pressure limitation (automatic switch over)
- PID-controller with 2 sets of parameters switchable by digital input
- Data for pressure set in bar
- Ramps up and down for pressure optionally activated by a digital input
- Force / pressure controller with one sensor
- Differential pressure control with two pressure sensors
- D - gain filter to stabilize the control behaviour
- Emergency function for output signal (EOUT)
- Two analogue feedback input are available
- Flow value (Q) alternative to the analogue input as parameter to be entered via software
- Simple and intuitive scaling and offset of the sensors.

Monitoring functions

- Monitoring error
- Cable break error for feedback sensor and current command signal
- 2 digital outputs to read the status

Other characteristics

- Current or voltage output to be set via software
- Card configuration via software, through the on-board USB port

3 - FUNCTIONAL SPECIFICATIONS

3.1 - Power supply

This card is designed for 12 to 30 VDC (typical 24 V) of a power supply. This power supply must correspond to the actual EMC standards. All inductivities at the same power supply (relays, valves) must be provided with an over voltage protection (varistors, freewheeling diodes).

It is recommended to use a regulated power supply (linear or switching mode) for the card supply and for the sensors.

3.2 - Electrical protections

All inputs and outputs are protected with suppressor diodes and RC-filters against transient overshoots.

3.3 - Digital Input

The card accepts digital input. The digital input must have a voltage from 12 to 24 V; low level: <2V, high level >10V. Input resistance 25 kohm. See the block diagram at point 4 for the electric connections.

3.4 - Pressure command (p)

The card accepts an analogue input signal. The command value is $0 \div 10 \text{ V}$ (RI = 25 kohm) or $4 \div 20 \text{ mA}$ (RI = 240 ohm).

3.5 - Flow command (Q)

The card accepts an analogue input signal. The speed command is $\pm 10 \text{ V}$ (RI = 90 kohm) or $4 \dots 12 \dots 20 \text{ mA}$ (RI = 240 ohm).

3.6 - Feedback values

The card accepts up to two analogue feedback inputs, values are $0 \div 10 \text{ V}$ (RI = 25 kohm) or $4 \div 20 \text{ mA}$ (RI = 240 ohm).

3.7 - Analogue output value

Output value can be in voltage or current, to be configured via software (parameter SIGNAL:U). The same parameter defines the polarity.

Voltage: $\pm 10 \text{ V}$ Differential output (PIN 15 / PIN 16).

Current: $4 \div 20 \text{ mA}$ (PIN 15 to PIN 12).

The analogue output has to be wired with shielded cables.

3.8 - Digital output

Two digital output are available, STATUS and READY. They are displayed by the READY and the A leds on the front panel.

Low level < 2 V High Level > 12 V (max 50 mA).

4 - WIRING DIAGRAM

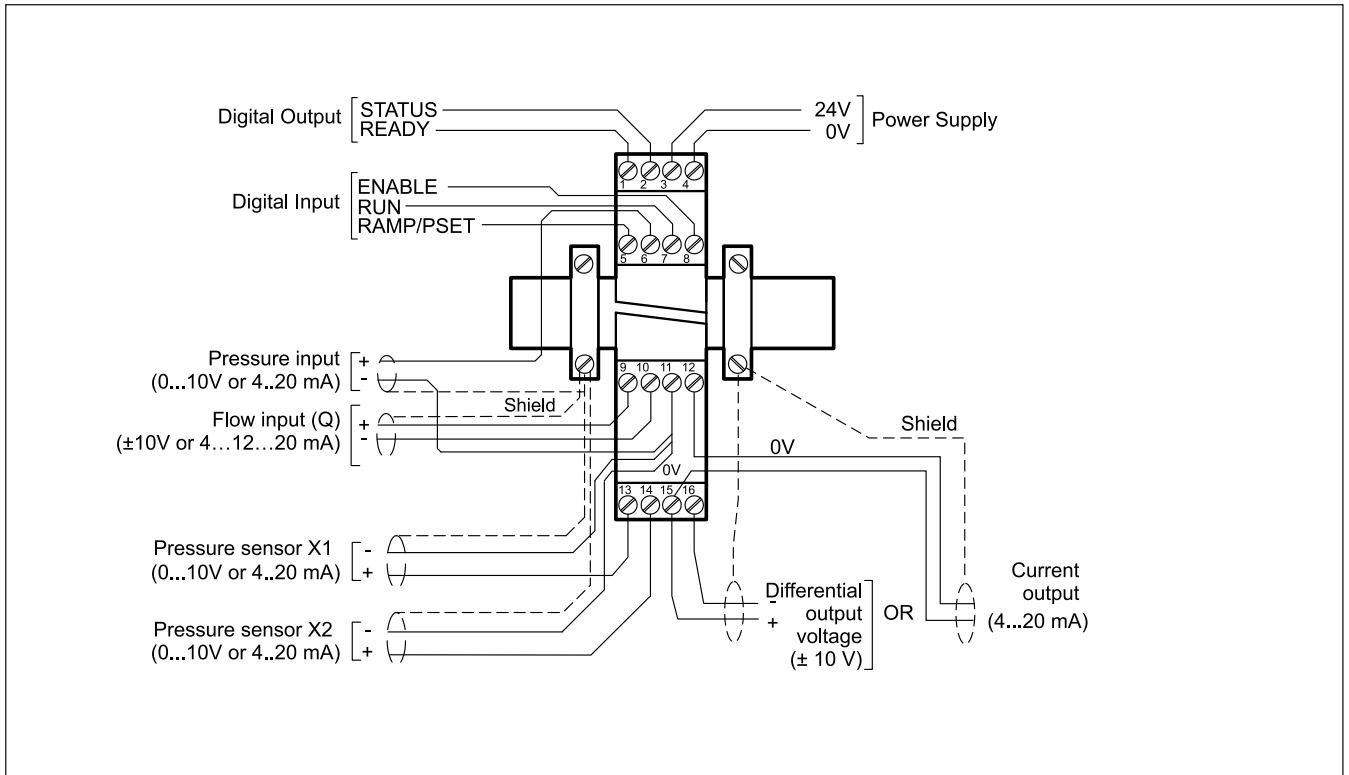

DIGITAL INPUT AND OUTPUT

- PIN 1** READY output:
General operationality, ENABLE is active and there are no sensor / command errors (by use of 4...20 mA sensors). This output corresponds to the READY led .
- PIN 2** STATUS output:
Error monitoring. The status output will be deactivated if the error is greater than the acceptability range. This output corresponds to the A led.
- PIN 5** RAMP/PSET input:
According to the setup of the PIN:5 parameter, it can be configured as:
- ramp on / off
- switching between the two available sets of parameters
- PIN 7** RUN input:
Controller activation; if the input is OFF and ENABLE is active, the flow command (PIN 9 / 10) is taken over as valve command value.
- PIN 8** ENABLE input:
This digital input signal initializes the application. The analogue output is active and the READY signal indicates that all components are working correctly. The Q command signal is controlling the output.

ANALOGUE INPUT

- PIN 6/11** Pressure / force command value (p)
range 0 ÷ 100% of system nominal pressure corresponds to 0 ÷ 10V or 4 ÷ 20 mA
- PIN 9/10** Flow command value (Q)
range ±100 % corresponds to ±10V or 4...12...20 mA
- PIN 13/11** Pressure sensor (feedback) value (X1)
range 0 ÷ 100% of nominal pressure of sensor corresponds to 0 ÷ 10V or 4 ÷ 20 mA
- PIN 14/11** Pressure sensor (feedback) value (X2)
range 0 ÷ 100% of nominal pressure of sensor corresponds to 0 ÷ 10V or 4 ÷ 20 mA

ANALOGUE OUTPUT

voltage

- PIN 15/16** Differential output (U)
± 100% corresponds to ± 10V differential voltage

current

- PIN 15/12** ±100% corresponds to 4 ÷ 20 mA

5 - INSTALLATION

For power supply and solenoid connections are recommended cable sections of 0.75 mm² up to 20 m length, and of 1.00 mm² up to 40m length.

For other connections use cables with a shielded jacket, connected to GND only on the card side.

NOTE : To observe EMC requirements it is important that the control unit electrical connection is in strict compliance with the wiring diagram.

As a general rule, the valve and the electronic unit connection wires must be kept as far as possible from interference sources (e.g. power wires, electric motors, inverters and electrical switches).

Complete protection of the connection wires can be requested in environments with critical electromagnetic interferences.

5.1 Start-up

The module must be mounted and wired with attentions to EMC requirements. A star orientated ground connection should be used when other power consumers are sharing the same power supply. Following points have to be taken in account for wiring:

- Signal cable and power cable have to be wired separately.
- Analogue signal cables must be shielded.
- Other cables should be shielded in case of strong electrical disturbance (power relays, frequency controlled power driver) or at cable lengths > 3m.

With high frequency EMI inexpensive ferrite elements can be used.

Take in account a separation between the power part (and power cables) and signal part when arrange the areas inside the electrical cabinet. Experience shows us that the area next to the PLC (24 V area) is suitable.

Low impedance between PE "protected earth" and DIN-Rail should be used. Transient interference voltages at the terminals are discharged via DIN-Rail to the local PE. The screens have to be connected directly next to the module via PE terminals.

The power supply should be carried out voltage regulated (i. e. PWM controlled). The low impedance of controlled power supplies facilitates improved interference damping, therefore the signal resolution will be increased.

Switched inductance (relays and solenoids) operating from the same power supply has to be damped by surge protection elements directly by the inductance.

6 - DEVICE SETUP

Card set-up is possible via software only.

The system can be controlled in open loop with the control signal Q, moving the servo cylinder forward and backward, for easy programming of the card and of the system calibration.

6.1 - Software EWM20_SmartManager

Il software EWM20_SmartManager è scaricabile dal sito web di Duplomatic MS, alla pagina di riferimento del prodotto.

Per connettere la scheda al PC utilizzare un cavo standard USB 2.0 A – B (standard USB per stampanti).

Una volta connesso, il software rileva tutte le informazioni dalla scheda e genera automaticamente la tabella degli ingressi e dei parametri disponibili, i valori di default, le unità di misura e delle brevi spiegazioni dei parametri per la configurazione.

Alcune funzioni (configurazione del baud rate, la modalità di controllo remoto, il salvataggio e l'analisi dei dati per successive valutazioni) vengono sfruttate per velocizzare la procedura di installazione.

Il software è ottimizzato per il SO Microsoft Windows 10 ed è ancora compatibile con Windows 7.



WARNING! For card series 20, the default baud rate to select in the software has changed from 9600 baud to 57600 baud. This is adaptable in OPTION / SETTINGS / INTERFACE.

6.2 - Parameters table

The parameters table is available in English or German. The language is set in the parameters.

The parameter setting can be done at *standard* level, easier, or *expert*, where a greater number of parameters is displayed and can be customized.

For a complete list of the parameters and their settings please refer to the Technical Manual 89550 ETM.

7 - MAIN FEATURES

This module serves to control pressures and forces on hydraulic actuators.

7.1 - Sequence of the positioning

The ENABLE signal initializes the application and error messages are deleted. The READY signal gets activated. The output signal to the control element is enabled. The drive can be controlled by the Q value or input. Setting RUN will start the PID controller.

A dynamic zero-overlap control valve is necessary for p/Q control. If the B-side of the cylinder can not be relieved, pressure in both cylinder sides has to be measured.

The cylinder can be driven in both directions (flow control in open loop) with the analogue Q command input value, limiting the max velocity.

The pressure limitation control function is only active when the Q signal is positive.

The p command value pre-sets the max differential pressure. If this pressure (or force) exceeds, the controller reduces the output signal to the valve (also in the negative range), so that the preset pressure will be kept. The direction of travel can be reversed to maintain the required force value.

The pressure/force control is determined via the analogue inputs X1 and X2. For differential pressure control the actual value is calculated as X1 – X2.

The output signal is available as a differential output for connection of control valves with integrated electronics.

7.2 - Emergency Output (EOUT)

This function is able to set the output at a specific value during a failure (e.g. sensor error or ENABLE disabled). It may be used to move the axis to one of the two end positions with a programmed velocity. The function can be disabled.



8 - CARD BLOCK DIAGRAM

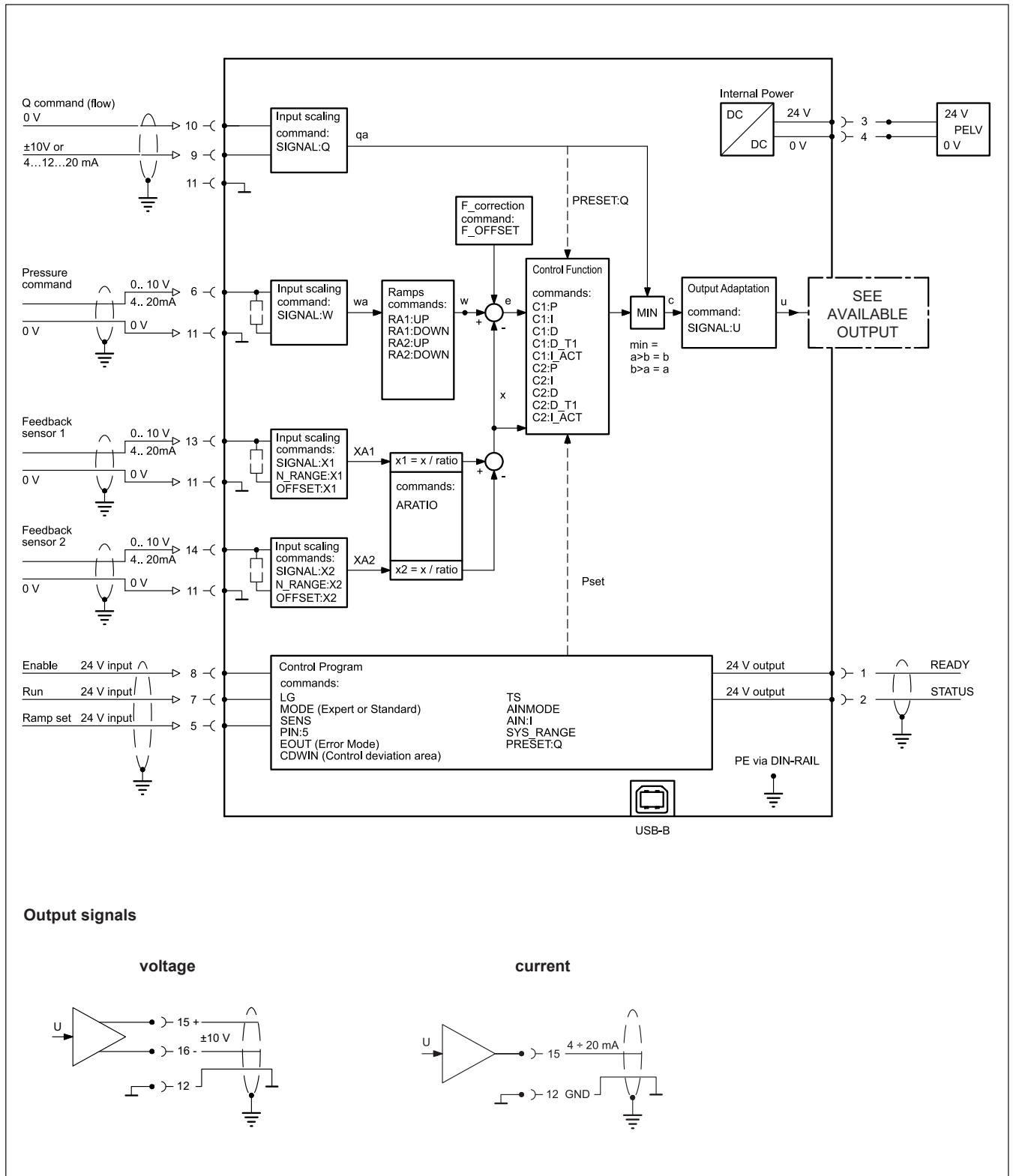

Output signals

voltage

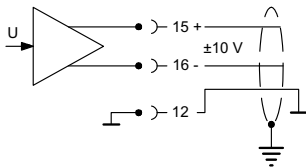

current

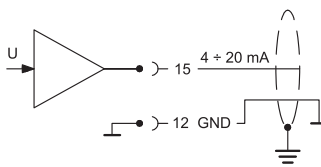

9 - OVERALL AND MOUNTING DIMENSIONS

