

# SUT

## SUPER UNIT (HYBRID HYDRAULIC POWER UNIT) SERIES 40

**TANK CAPACITY**  
100 litres

**MOTOR PUMP FLOW RATE**  
up to 81 l/min



### DESCRIPTION

SUT\*\*\*\*-40-YCP-Q-D1

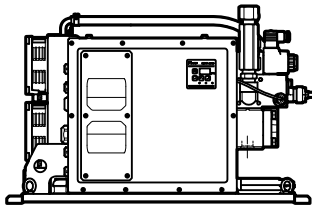

SUT\*\*\*\*-40-YCP-Q100-D1

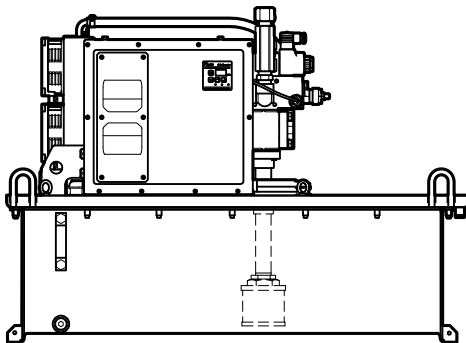

SUT\*\*\*\*-40-YCP-Q100M\*-D1

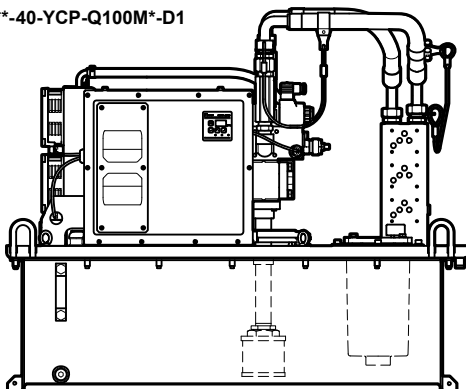

Daikin Industries LTD. designs and manufactures hybrid SUPER UNITS by combining hydraulic technology with an interior permanent magnet synchronous motor.

This results in a power pack that delivers high torque and maximum efficiency while minimising heat and noise generation. The motor-pump's high efficiency ensures minimal oil heating.

Using the SUPER UNIT provides several benefits for the machinery it operates on, including extended oil life, improved durability of heat-sensitive components, and reduced heat dissipation into the surrounding environment.

The power pack is designed for 3-phase AC 380 to 480V 50/60 Hz.

In SUTs equipped with a dual pump, the primary pump delivers high pressure and limited flow. When the flow demand exceeds the capacity of the primary pump, the secondary pump is activated to provide the required flow at a lower pressure.

The switch from single to combined operation is managed by a solenoid valve, which can be controlled automatically by the SUT or triggered by an external analogue signal from the PLC.

The SUPER UNITS are deliverable with:

- mounting frame, no tank
- 100-litres tank, equipped with suction filter, level switch and blind plate that customers may customize.
- 100-litres tank equipped with suction filter, level switch, multi-station manifold for stackable valves and return filter.

Accessories and valves can be ordered separately.

## 1 - IDENTIFICATION CODE

### 1.1 - Versions with single pump

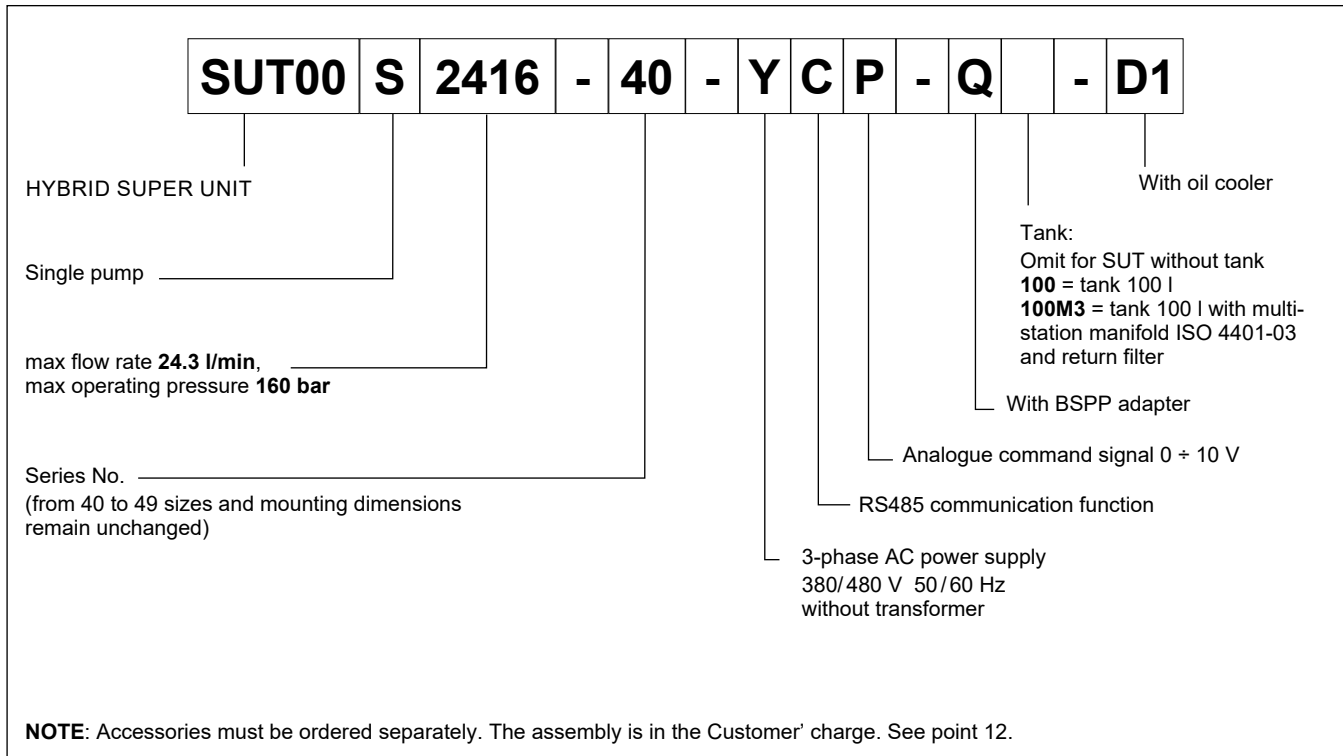

### 1.2 - Versions with double pump

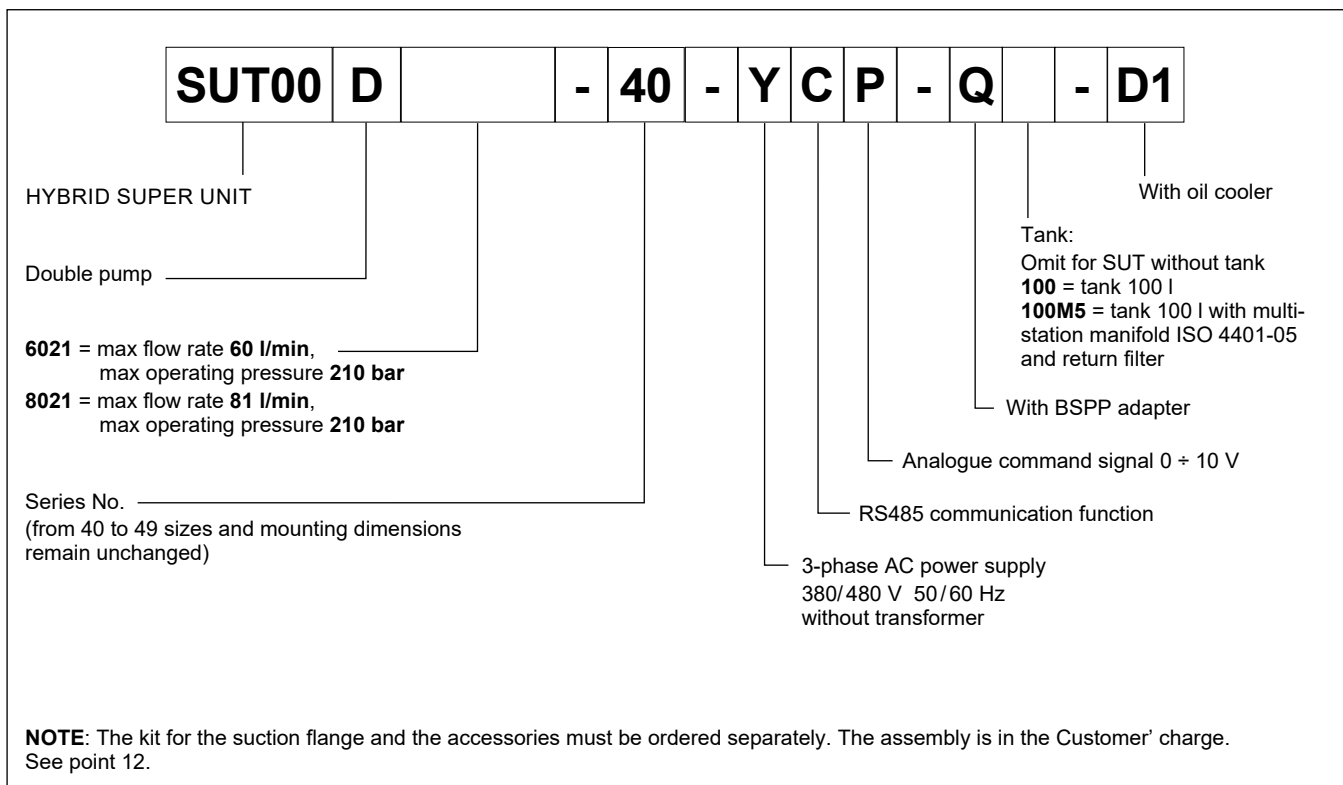

**2 - SPECIFICATIONS**

		SUT00S2416		SUT00D6021		SUT00D8021	
		Q	Q100	Q	Q100	Q	Q100
Maximum operating pressure	bar	160		210		210	
Operating pressure range: - 1 <sup>st</sup> pump (HP) - 1 <sup>st</sup> + 2 <sup>nd</sup> pump (HP+LP)	bar	5 ÷ 160 -		5 ÷ 210 5 ÷ 70		5 ÷ 210 5 ÷ 70	
Operating flow range: - 1 <sup>st</sup> pump (HP) - 1 <sup>st</sup> + 2 <sup>nd</sup> pump (HP+LP)	l/min	3.5 ÷ 24.3 -		3.1 ÷ 21.2 8.8 ÷ 60		4.1 ÷ 28.7 11.6 ÷ 81	
Tank capacity	l	-	100	-	100	-	100
Oscillating volume		-	30	-	30	-	30
Main supply voltage permissible voltage fluctuation		3-phase AC 380 V to 480 V - 50 / 60 Hz ±10%					
Controller supply voltage		-		24V DC (min 50 W)			
Nominal motor power	kW	3.0		3.0		4.0	
Rated current	A	9.3		10.3		14.1	
No-fuse breaker capacity	A	15		15		20	
Ambient temperature range	°C	0 to +40					
Fluid temperature range in the tank	°C	0 to +60 (recommended +15 to +50)					
Fluid contamination degree		ISO 4406:1999 class 20/18/15					
Viscosity		Viscosity grade: ISO VG32 to 68 • Viscosity range: 15 to 400 mm <sup>2</sup> /s					
Operating ambient humidity	RH	< 85%, non-condensing					
Protection class		IP44; controller box IP54					
Noise level ( <b>NOTE</b> )	dB	full cut-off (160 bar) 52 dBA 24.3 l/min (20 bar) 70 dBA		full cut-off (210 bar) 57 dBA 60 l/min (20 bar) 74 dBA		full cut-off (210 bar) 57 dBA 81 l/min (20 bar) 77 dBA	
Installation		altitude max 1000 m, indoor, fixed on a flat surface without vibrations.					
Mass: - without tank - 100 - 100M*	kg	53 - -	- 126 132	62 - -	- 133 148	65 - -	- 147 164

external input signals	analogue input	2 channels; pressure command 0 ÷ 10 V; flow command 0 ÷ 10 V.
	digital input	6 channels, photo coupler insulation, 24V DC (max 27 V DC), 5 mA per channel.
external output signals	analogue output	2 channels; pressure monitor 0 ÷ 10 V; flow monitor ± 10 V.
	digital output	2 channels, photo coupler insulation, open collector output, 24V DC, 50 mA max per channel.
	contact output	1, relay output, contact capacity: 30 V DC; resistance load 0.5 A; 1 common contact.

**NOTE:** The noise level is representative of the four-way average at a distance of 1 m.

### 3 - SUT00S2416 - CHARACTERISTICS

Values obtained and rated for ambient temperature  $\leq 40\text{ }^{\circ}\text{C}$  and fluid temperature  $\leq 60\text{ }^{\circ}\text{C}$ , in continuous operation (S1)

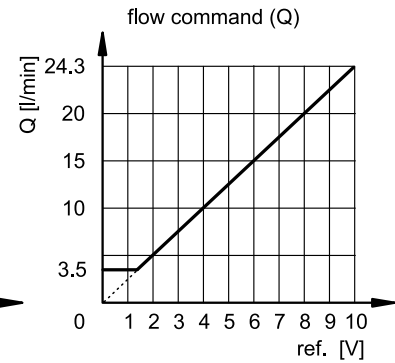
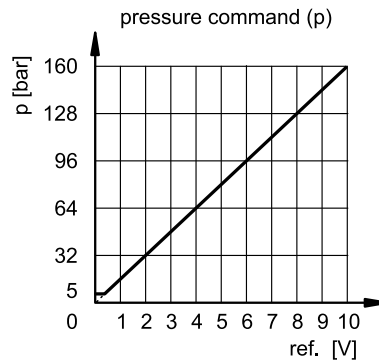
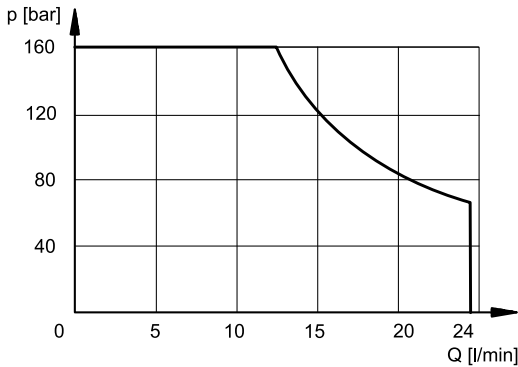

### 4 - SUT00S WITHOUT TANK

#### 4.1 - SUT00S2416-40-YCP-Q-D1 - Main parts and options

dimensions in mm

**CIRCUIT DIAGRAM**

P	Pressure port: 3/8" BSPP
S	Suction port: 3/4" BSPP N. 1 OR type 4093 (23.4x3.5)
DR	Drain port: 3/8" BSPP
1	Control panel
2	Cooler
3	Fixing frame

## 4.2 - SUT00S2416-40-YCP-Q-D1 - Overall dimensions and mounting

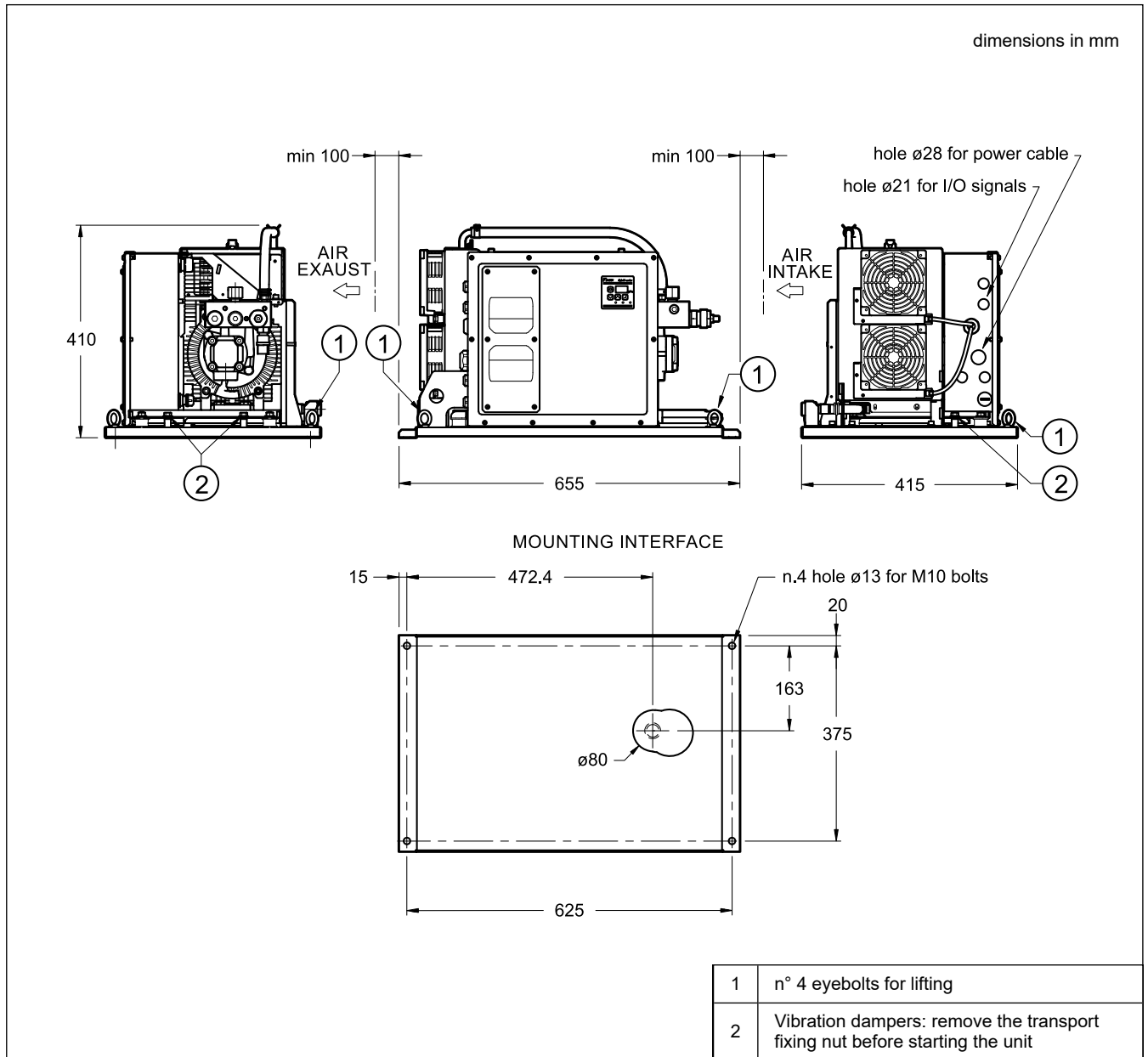

**NOTE:** The use of hose whip restraints devices both at pump side and at manifold side is strongly recommended, to avoid the possible swip-off from the hose fitting during operation.

The SUT00S2416-40-YCP-Q100M3-D1 models come already equipped with these devices.

## 5 - SUT00S WITH TANK

### 5.1 - SUT00S2416-40-YCP-Q100 - Main parts and options

dimensions in mm

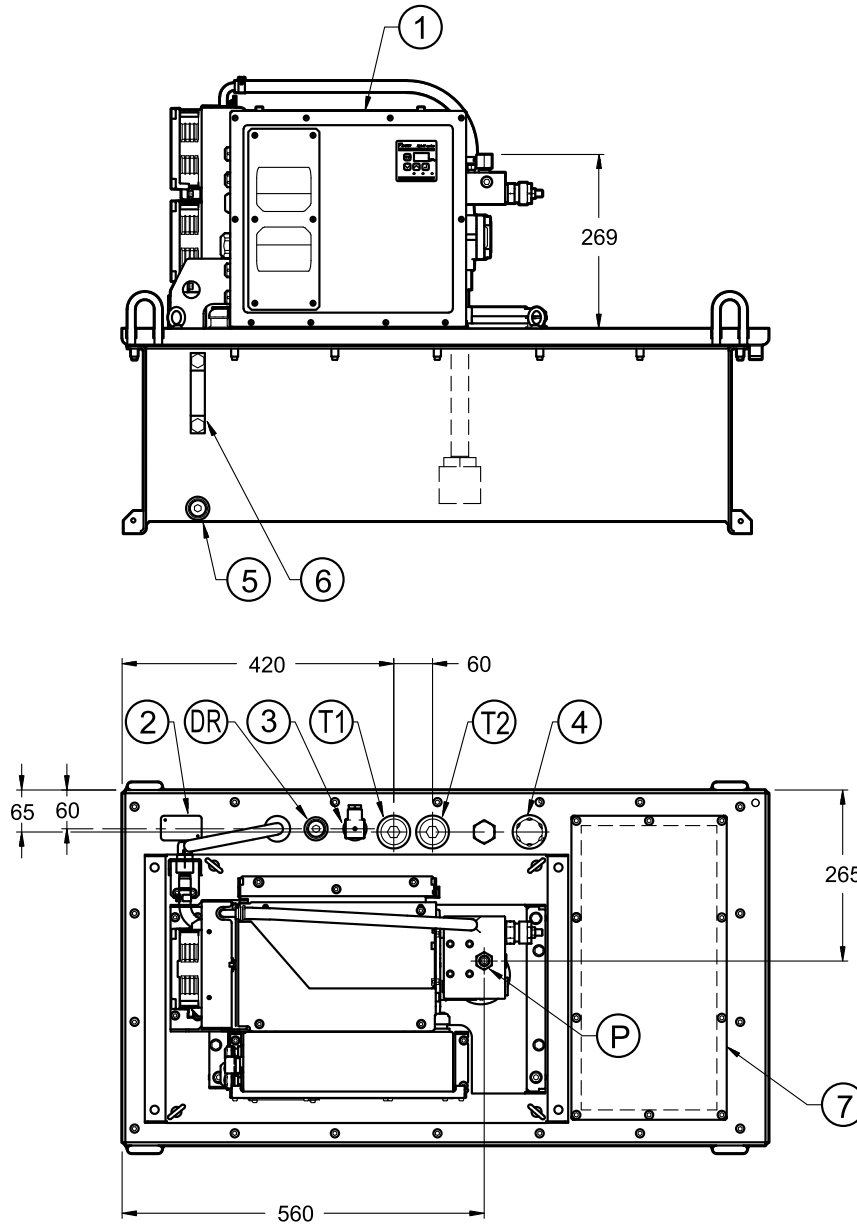

		1	SUT hybrid unit
		2	Identification label
		3	Level switch
		4	Oil filler port with air breather
		5	Oil sampling and tank drain port
		6	Oil level indicator: upper 100 L; lower 70 L
		7	Blind plate 230x460 mm
P	Pressure port: 3/8" BSPP delivered with plug		
T1	Port for return line: 1" BSPP delivered with plug		
T2	Port for return line: 1" BSPP delivered with plug		
DR	Drain port: 1/2" BSPP delivered with plug		

## 5.2 - SUT00S2416-40-YCP-Q100M3 - Main parts and options

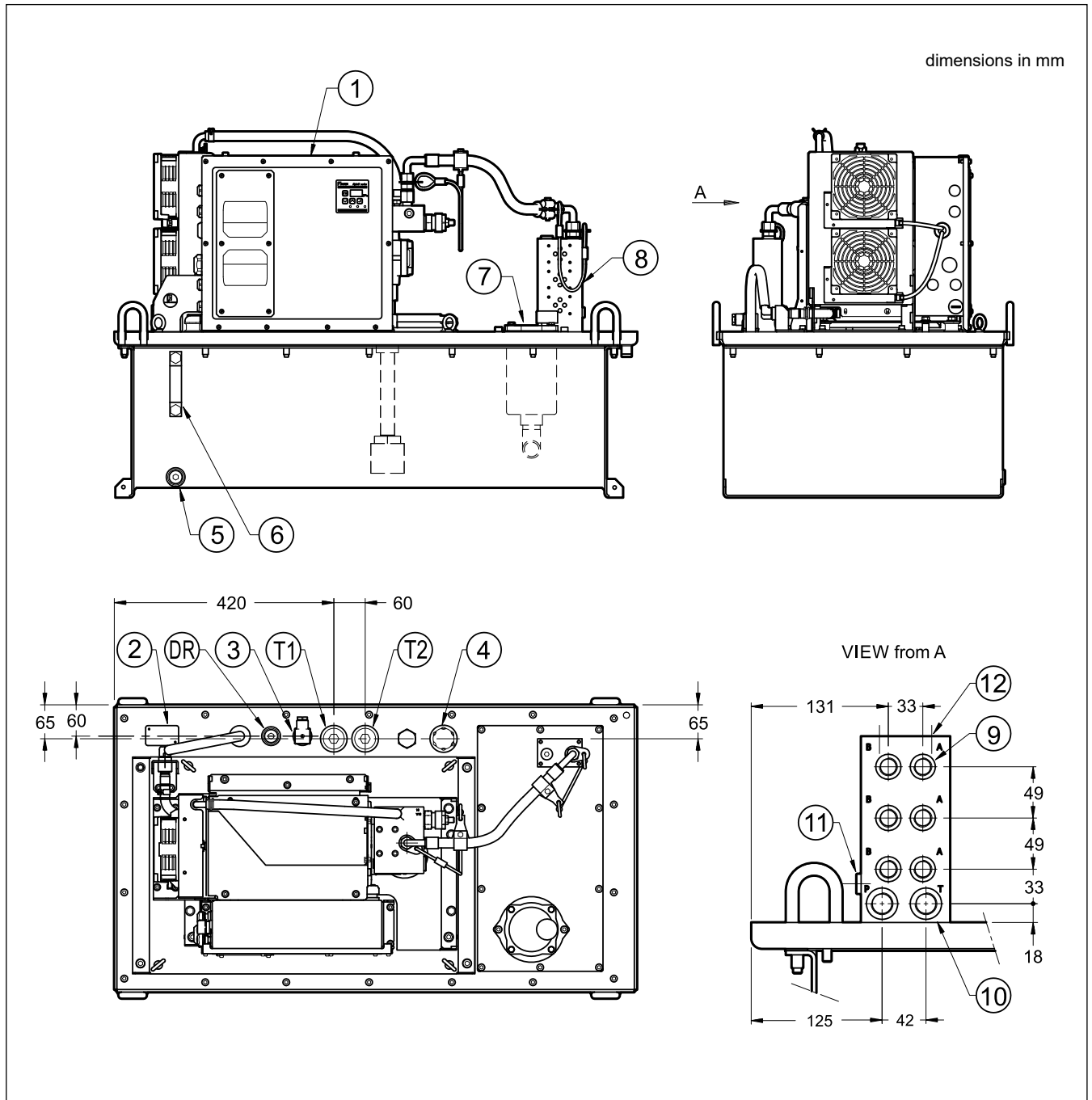

T1	Port for return line: 1" BSPP delivered with plug
T2	Port for return line: 1" BSPP delivered with plug
DR	Drain port: 1/2" BSPP delivered with plug
1	SUT hybrid unit
2	Identification label
3	Level switch
4	Oil filler port with air breather
5	Oil sampling and tank drain port

6	Oil level indicator: upper 100 L; lower 70 L
7	Return filter type FRI-TB100, with visual clogging indicator. (See catalogue 95 180)
8	3-station manifold for ISO 4401-03 valves
9	A, B working lines: 3/8" BSPP
10	P, T ports: 1/2" BSPP
11	Pressure gauge port: 1/4" BSPP
12	Mounting interface for P2 stackable subplate (See catalogue 52 000)

### 5.3 - SUT00S2416-\* with tank - Overall dimensions and mounting

The drawing is representative of both the versions with tank.

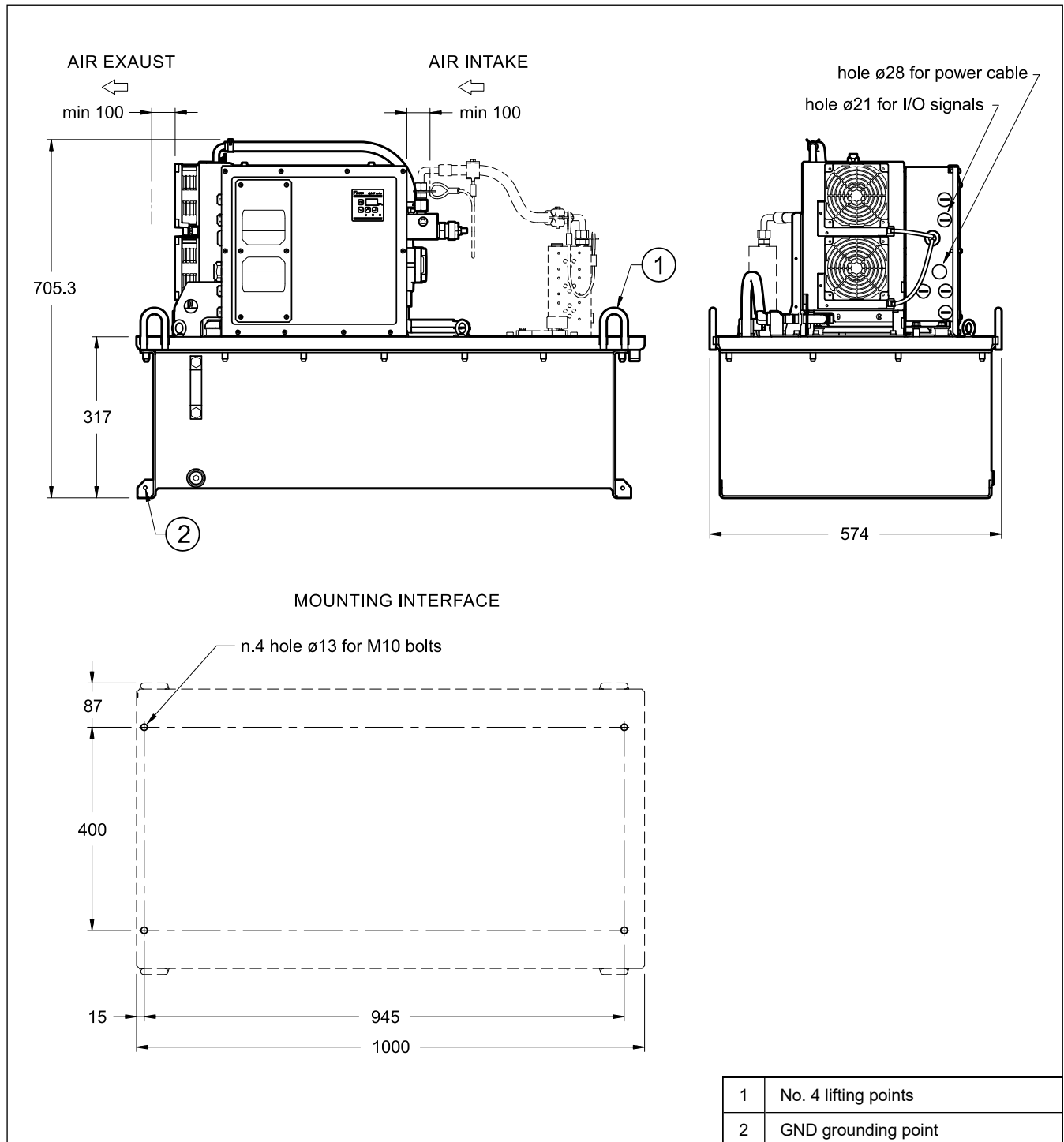

**NOTE:** The use of hose whip restraints devices both at pump side and at manifold side is strongly recommended to avoid the possible swip-off from the hose fitting during operation.

The SUT00S2416-40-YCP-Q100M3-D1 models come already equipped with these devices.

5.4 - SUT00S2416-\* with tank - Circuit diagram

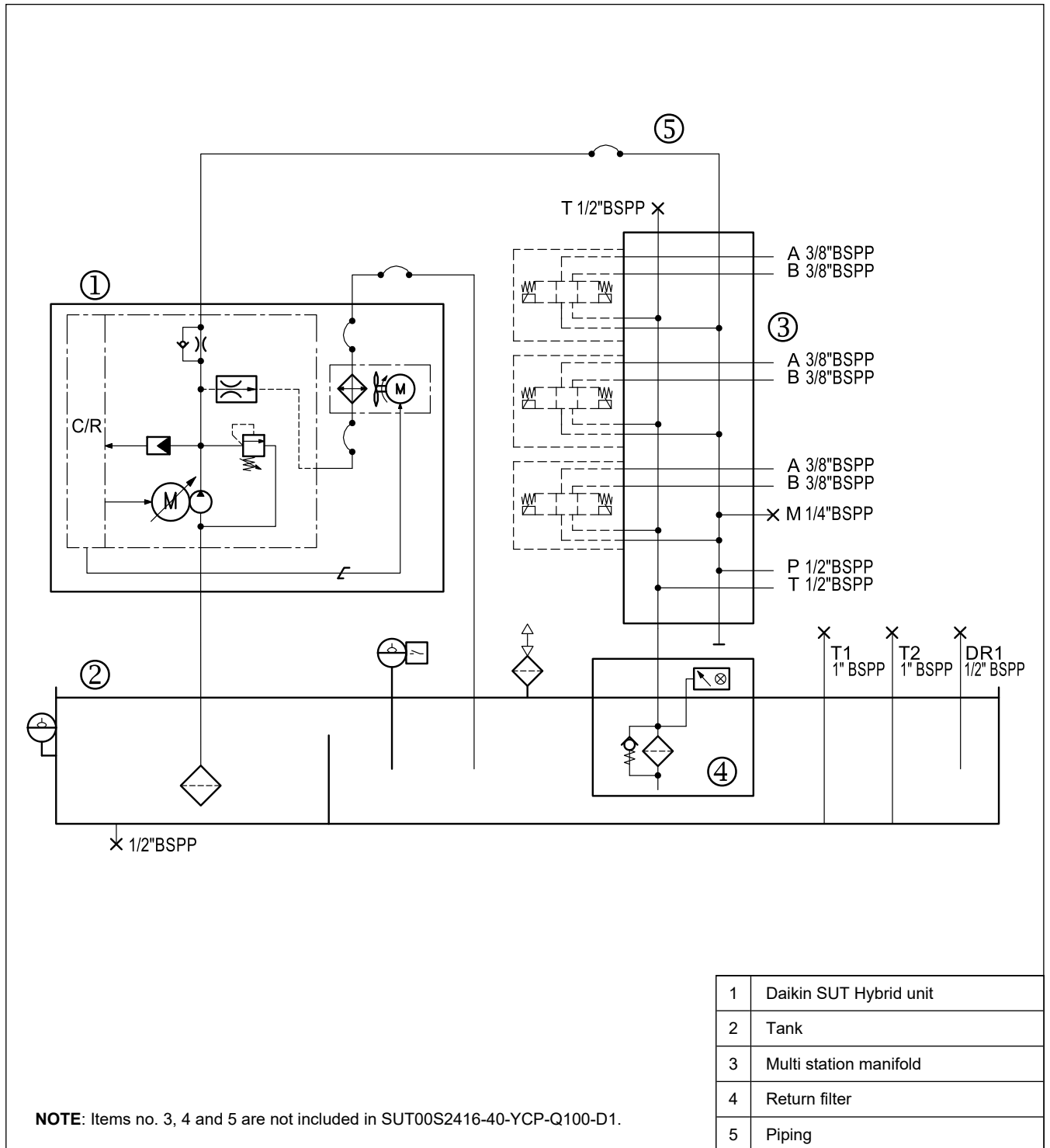

## 6 - SUT00D\* - CHARACTERISTICS CURVES AND P/Q COMMANDS

Double pump type units allow to work with a high flow at limited pressure or with a limited flow at high pressure. The switching between them is done by means of a dedicated solenoid valve. This achieves sustained high pressure control, as is often required for presses and other equipment.

The switching between these two conditions can be carried out autonomously by the SUT, or by means of an analogue signal coming from the PLC. This configuration is set by parameter (see points 9.4 and 9.5).

Diagrams below shows the relationship between the PQ analogue inputs and the SUT internal command.

### 6.1 - HIGH PRESSURE MODE / low flow rate (PH pump only)

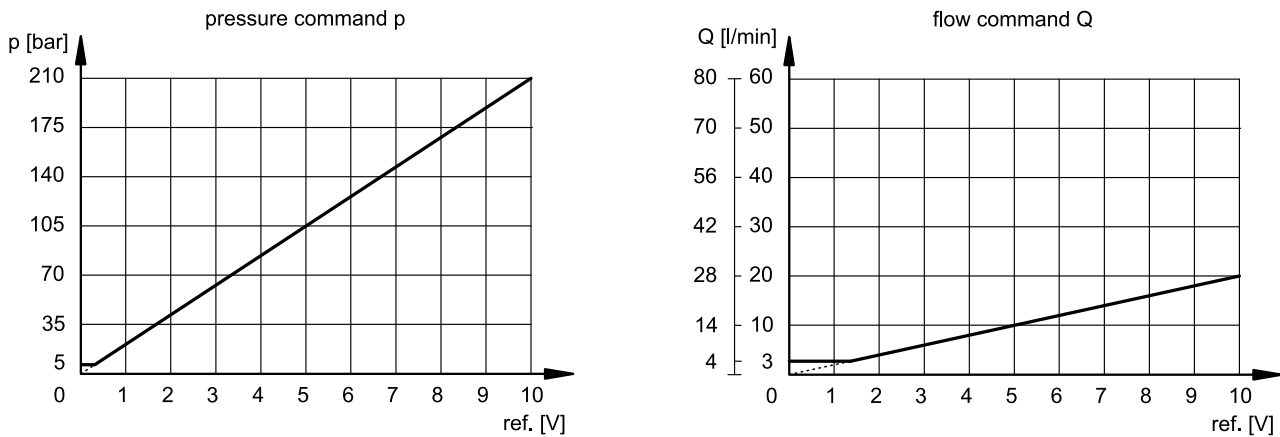

### 6.2 - LOW PRESSURE MODE / high flow rate (combined pumps PH+PL)

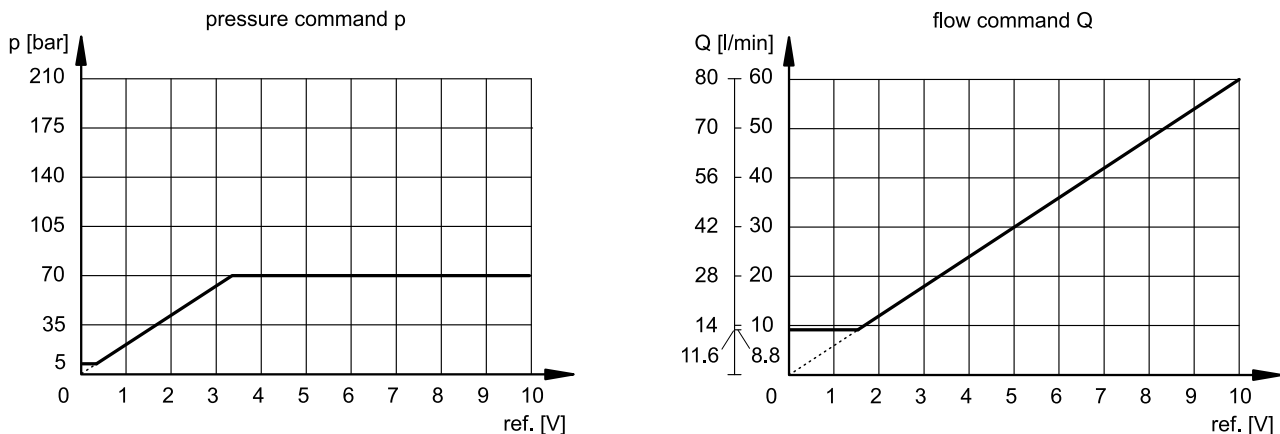

### 6.3 - Pressure - flow rate diagrams

Values obtained and rated for ambient temperature  $\leq 40^\circ\text{C}$  and fluid temperature  $\leq 60^\circ\text{C}$ , in continuous operation (S1)

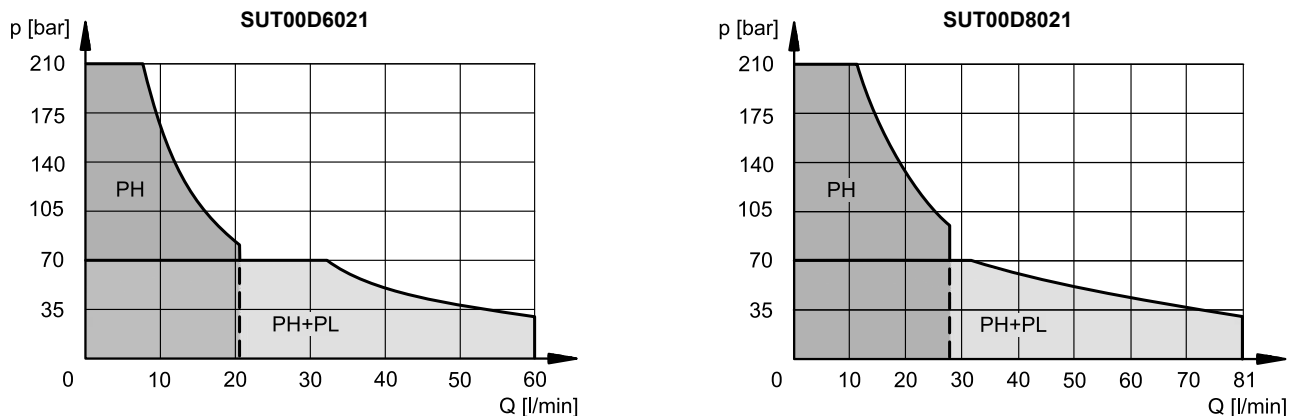

## 7 - SUT00D\* - MODELS WITHOUT TANK

### 7.1 - SUT00D6021-40-YCP-Q-D1 - Main parts and options

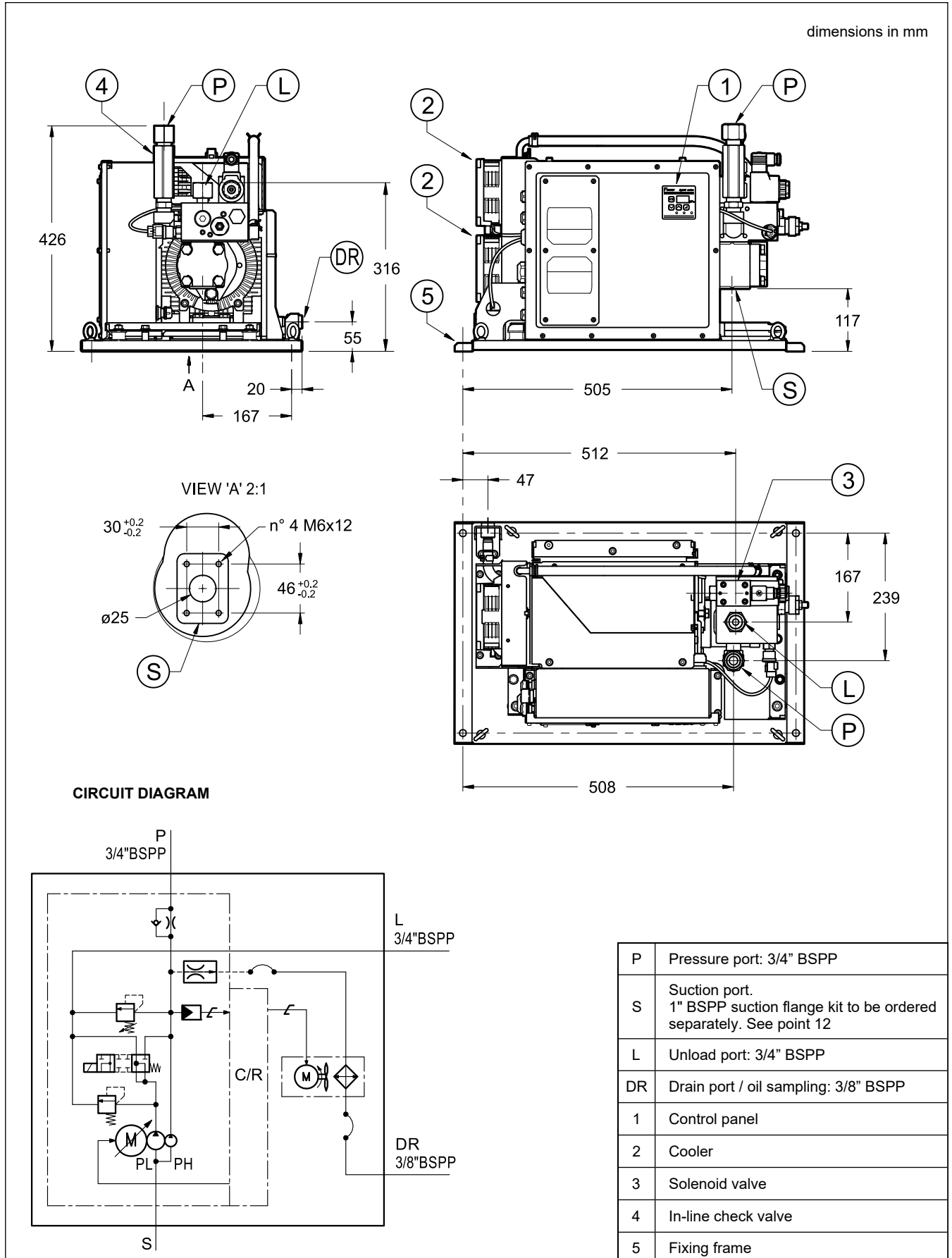

## 7.2 - SUT00D6021-40-YCP-Q-D1 - Overall dimensions and mounting

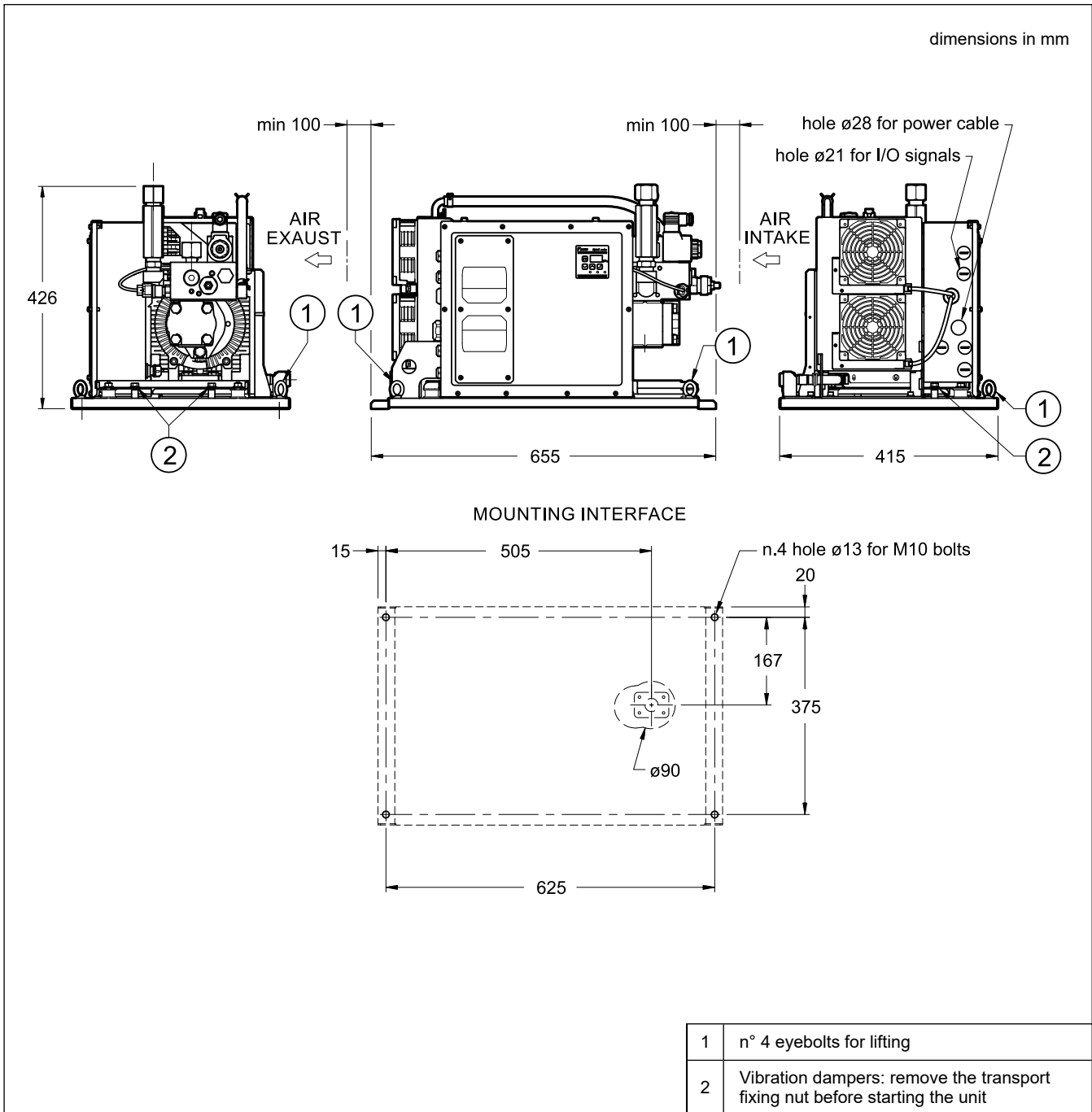

**NOTE:** The use of hose whip restraints devices both at pump side and at manifold side is strongly recommended to avoid the possible swip-off from the hose fitting during operation.

The SUT00D\*021-40-YCP-Q100M5-D1 models come already equipped with these devices.

7.3 - SUT00D8021-40-YCP-Q-D1 - Main parts and options

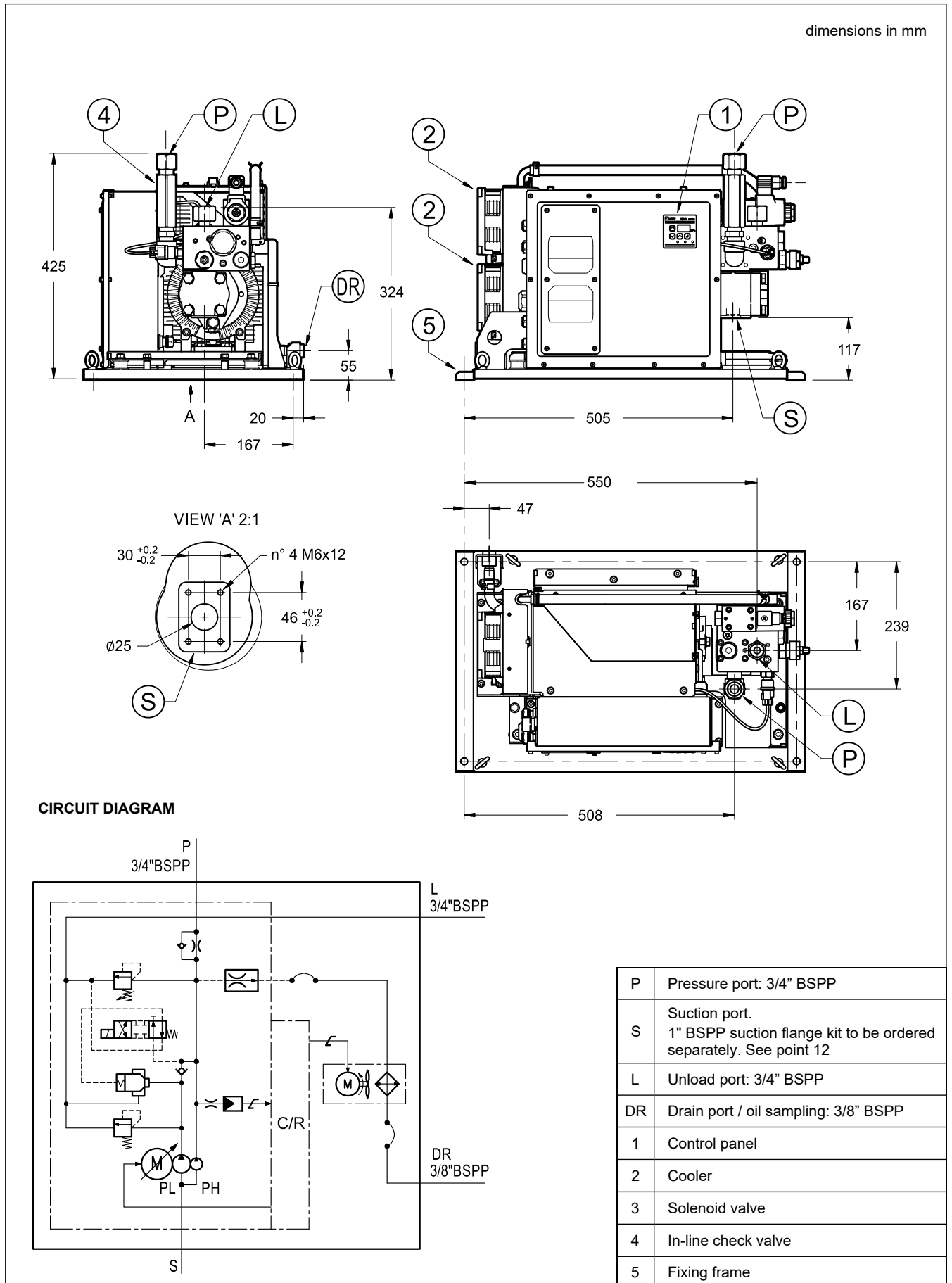

## 7.4 - SUT00D8021-40-YCP-Q-D1 - Overall dimensions and mounting

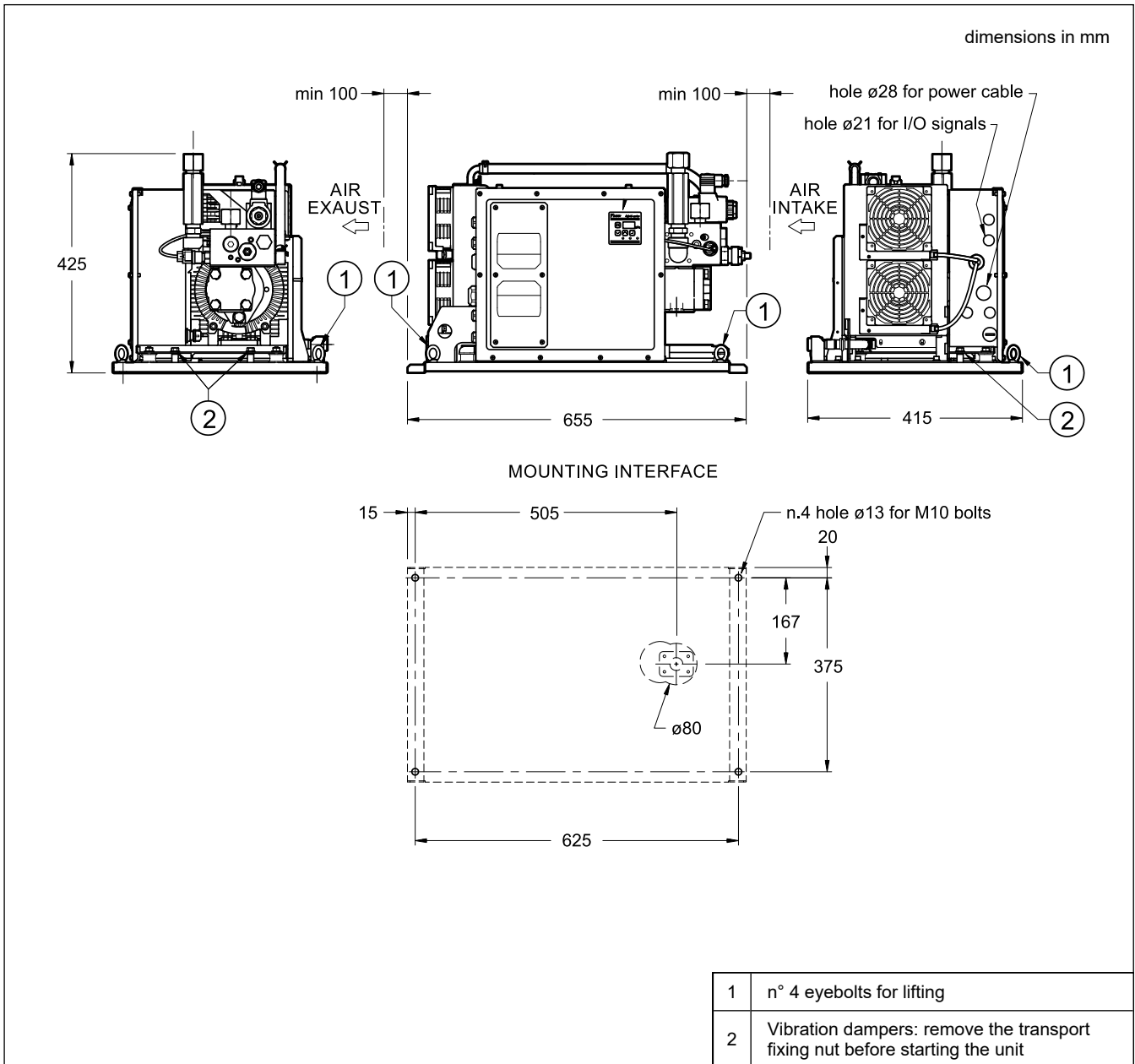

**NOTE:** The use of hose whip restraints devices both at pump side and at manifold side is strongly recommended to avoid the possible swip-off from the hose fitting during operation.

The SUT00D\*021-40-YCP-Q100M5-D1 models come already equipped with these devices.

## 8 - SUT00D\* - MODELS WITH TANK

### 8.1 - SUT00D\*021-40-YCP-Q100 - Main parts and options

The drawing is representative of both SUTD6021 and SUTD8021 versions with tank.

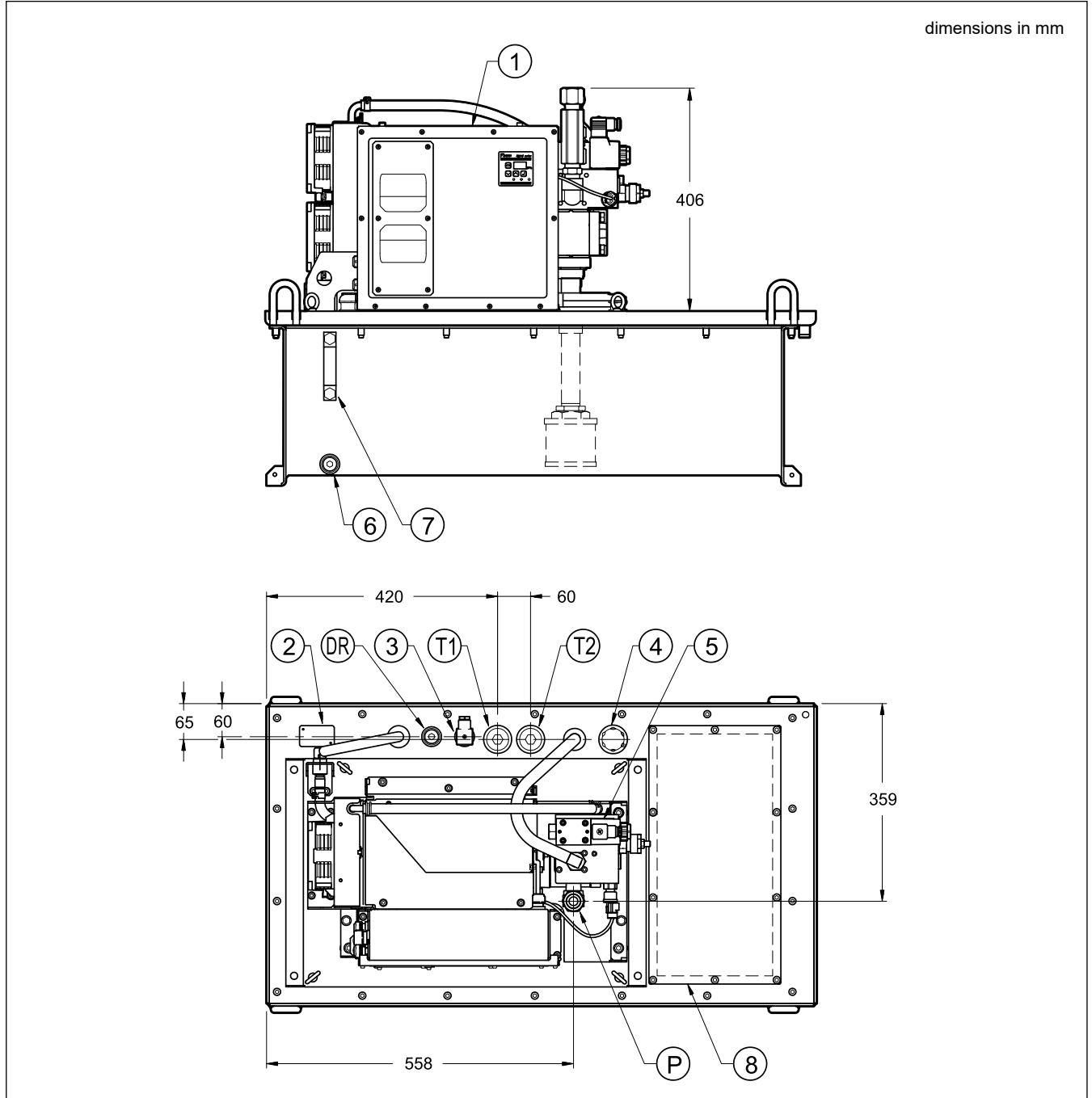

P	Pressure port: 3/8" BSPP delivered with plug
T1	Port for return line: 1" BSPP delivered with plug
T2	Port for return line: 1" BSPP delivered with plug
DR	Drain port: 3/4" BSPP delivered with plug
1	SUT hybrid unit
2	Identification label

3	Level switch
4	Oil filler port with air breather
5	Solenoid valve
6	Oil sampling and tank drain port
7	Oil level indicator: upper 100 L; lower 70 L
8	Blind plate 230x460 mm

## 8.2 - SUT00D\*021-40-YCP-Q100M5 - Main parts and options

The drawing is representative of both SUTD6021 and SUTD8021 versions with tank.

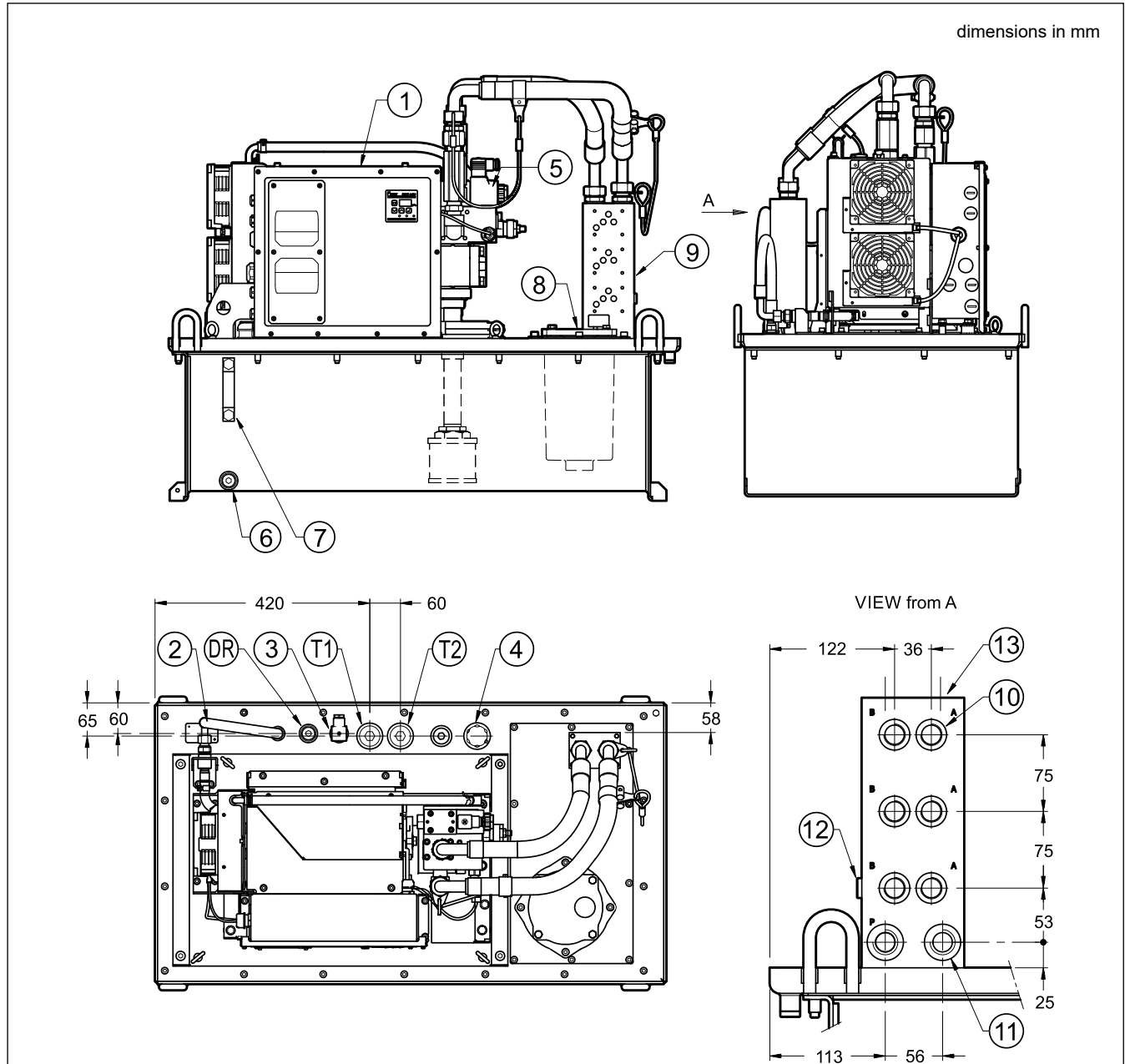

dimensions in mm

T1	Port for return line: 1" BSPP delivered with plug
T2	Port for return line: 1" BSPP delivered with plug
DR	Drain port: 3/4" BSPP delivered with plug
1	SUT hybrid unit
2	Identification label
3	Level switch
4	Oil filler port with air breather
5	Solenoid valve
6	Oil sampling and tank drain port

7	Oil level indicator: upper 100 L; lower 70 L
8	Return filter type FRI-TB114, with visual clogging indicator. (See catalogue 95 180)
8	3-station manifold for ISO 4401-05 valves
10	A, B working lines: 1/2" BSPP
11	P, T ports: 3/4" BSPP
12	Pressure gauge port: 1/4" BSPP
13	Mounting interface for subplates (see point 12)

### 8.3 - SUT00D\*- with tank - Overall dimensions and mounting

The drawing is representative of both the versions with tank.

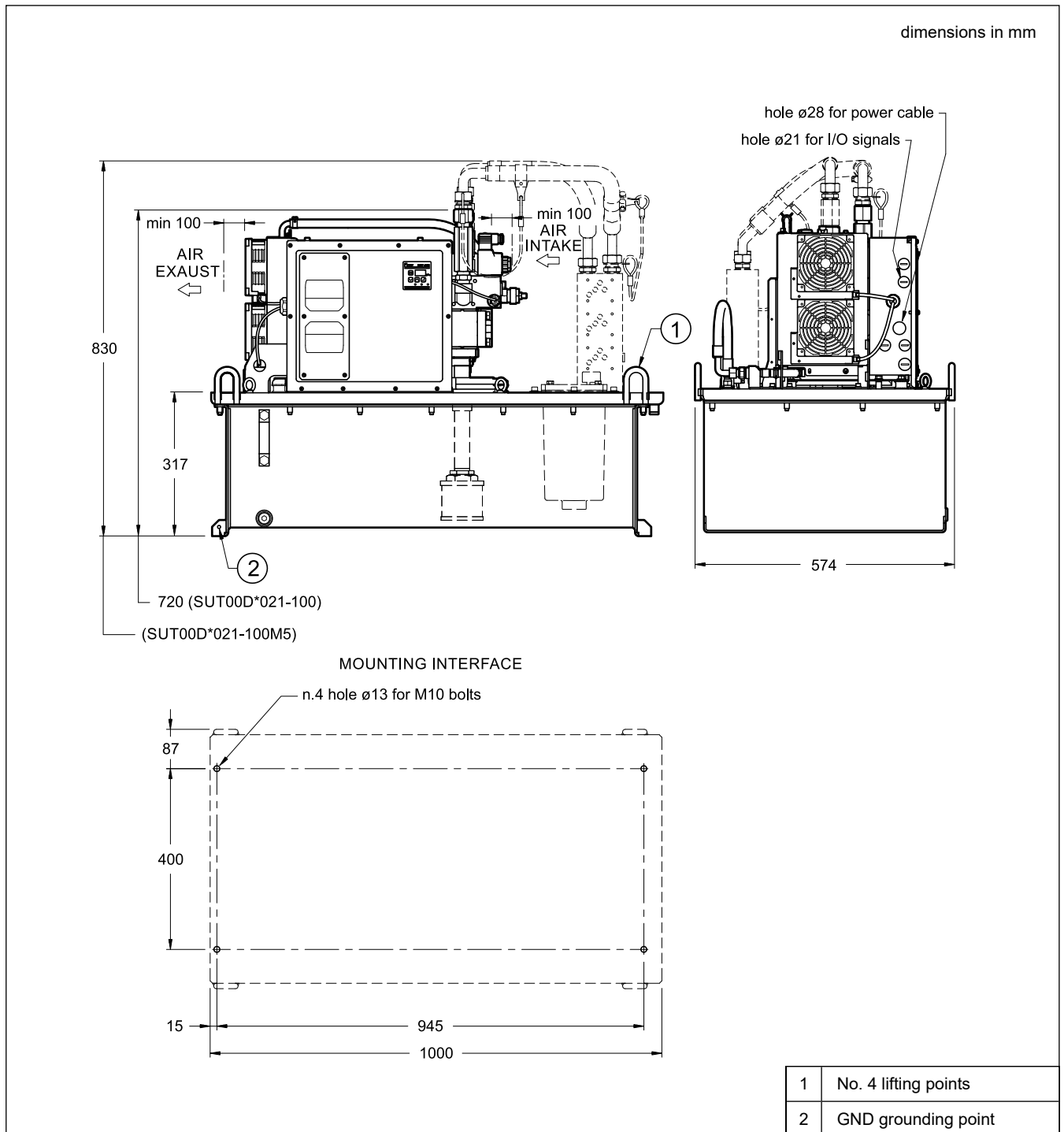

**NOTE:** The use of hose whip restraints devices both at pump side and at manifold side is strongly recommended to avoid the possible swip-off from the hose fitting during operation.

The SUT00D\*021-40-YCP-Q100M5-D1 models come already equipped with these devices.

### 8.4 - SUT00D6021 with tank - Circuit diagram

The drawing is representative of all the SUT00D6021 with tank.

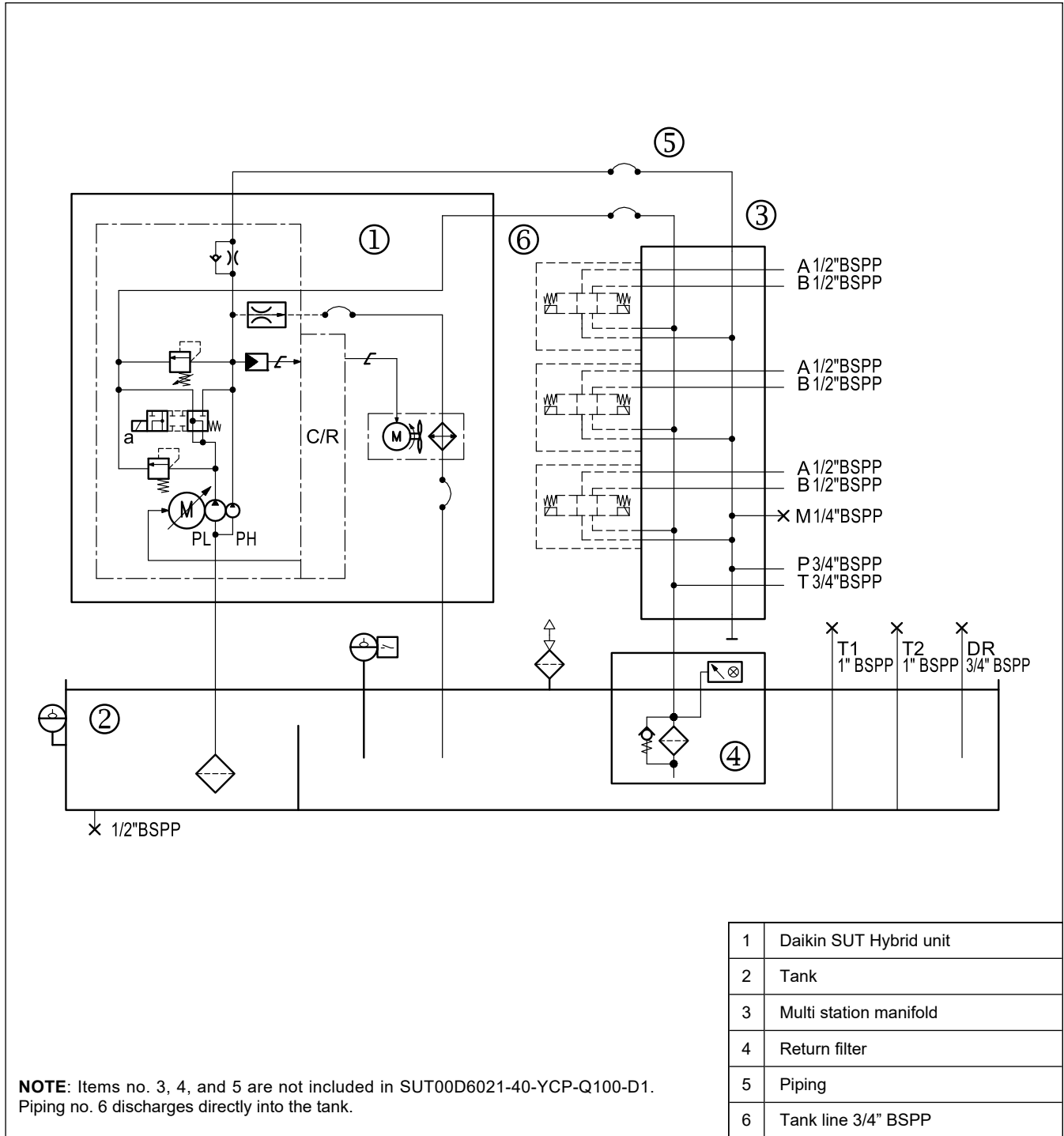

8.5 - SUT00D8021 with tank - Circuit diagram

The drawing is representative of all the SUT00D8021 with tank.

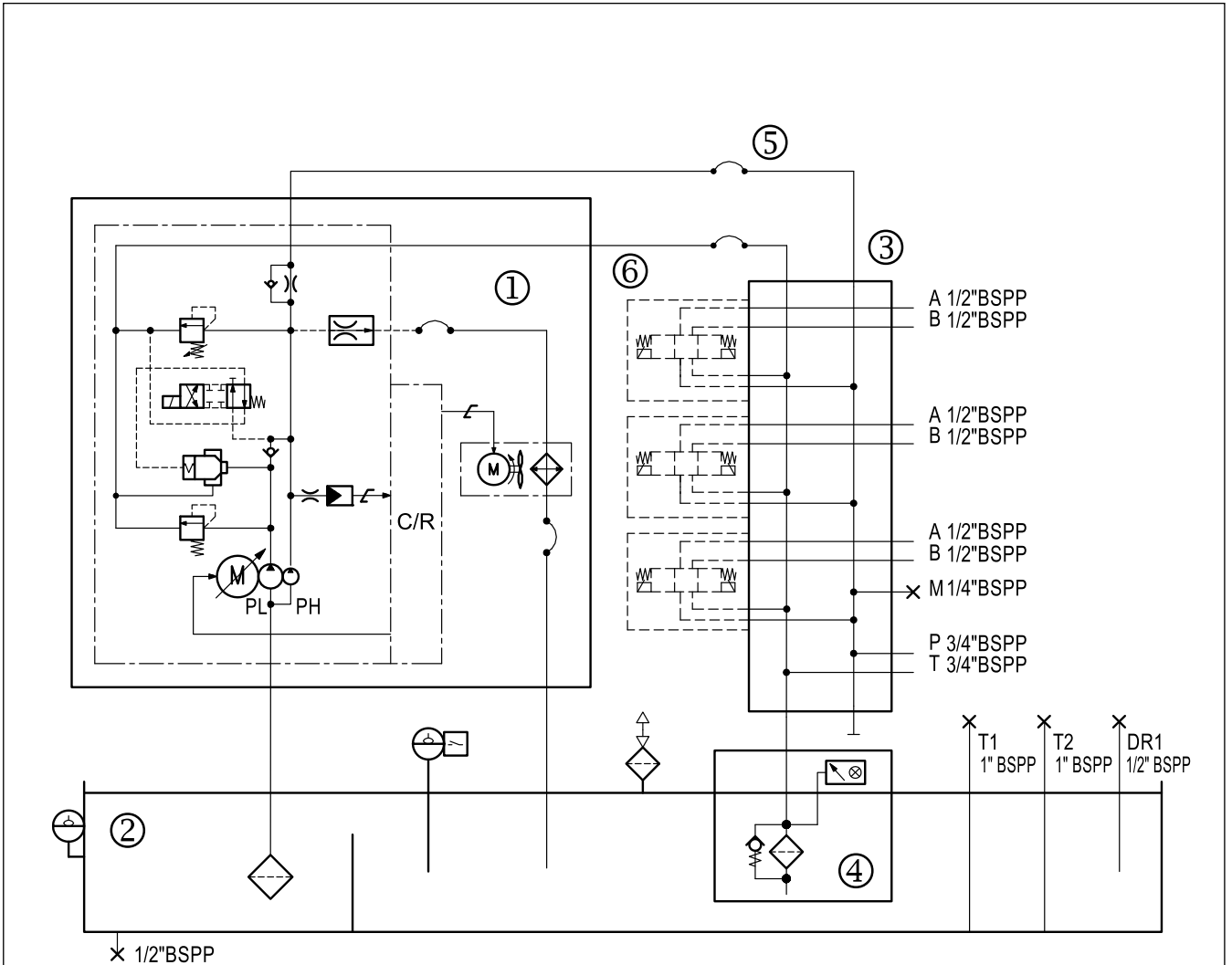

1	Daikin SUT Hybrid unit
2	Tank
3	Multi station manifold
4	Return filter
5	Piping
6	Tank line 3/4" BSPP

**NOTE:** Items no. 3, 4, and 5 are not included in SUT00D8021-40-YCP-Q100-D1.  
Piping no. 6 discharges directly into the tank.

## 9 - WIRING

### 9.1 - EMC 2014/30/EU compliance

The EN 61800-3:2004 (Second environment / PDS Category “C3”) requires the installation of a surge on protection device and a noise filter between the breaker and the SUT hybrid unit on the power source line.

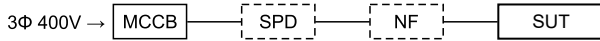

The assessment for the installation of these components is the responsibility of the machine manufacturer, as compliance with EMC regulations involves the entire machine on which the SUT unit will be installed. If SUT has to be compliance EMC 2014/30/EU as a standalone, noise filter and protection device are must have.

Surge protection device (SPD) and noise filters can be ordered separately. See point 12.

### 9.2 - Wiring notes

- Install a no-fuse breaker and a ground fault interrupter compliant with European Standard EN 60947-2 in the main power supply of SUT, to protect the electrical circuits against shorting and overcurrent, and to prevent electric shocks.
- Use straight type terminals for the power supply wiring.
- Use suitable electric cable in accordance with the power supply capacity. In addition, connect the cables correctly in accordance with the wiring guide.
- Provide a ground connection in compliance with the law in the relevant country. Connect the grounding wire directly with no breaker in the line.
- Avoid the entry of waste metal such as screws and wiring debris, or combustible matter such as wood waste or oil, inside the control unit.
- Use a commercial power supply for the power source. The use of an inverter power supply may cause burn damage to the unit.
- Before accessing the interior of the control unit, check that the unit's power supply has turned OFF and then wait at least 5 minutes.

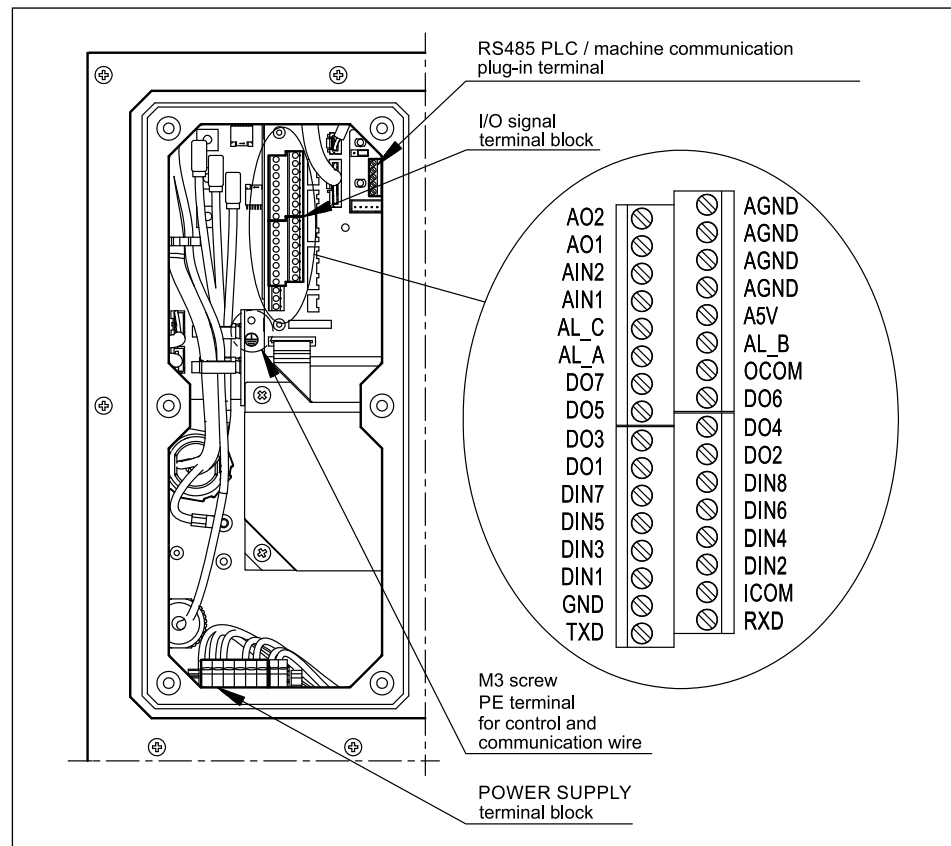

### 9.3 - Cables

For the main power connection (L1, L2 and L3) use cables with 4-wires.

SUT00D2416, SUT00D6021: > 1.5 mm<sup>2</sup> section (AWG 16).

SUT00D8021: > 2.5 mm<sup>2</sup> section (AWG 14).

For coil connection of the solenoid valve on SUTD\* models: 1 mm<sup>2</sup>

For signals and for ModBUS communication to the PLC use shielded cables with section from 0.35 mm<sup>2</sup> to 0.5 mm<sup>2</sup> (AWG 20 ~ 22).

Related cable clamps must be IP54 min.

### 9.4 - Solenoid valve of SUT00D\*\*

The wiring of the solenoid valve is in the customer's charge, as it is not powered by the SUT controller. The connector with surge killer and led is supplied.

	Nominal voltage [V]	Resistance at 20°C [Ω]	Current consumpt. [A]	Power consumpt [W]	Permissible voltage [%]	IP degree (NOTE)
DC	24	18,6	1,22	29.2	90 ÷ 110	IP65

**NOTE:** The IP protection degree from atmospheric agents IEC 60529 is guaranteed only when the connector is correctly connected and installed.

## 9.5 - SUT00S2416 Wiring diagram

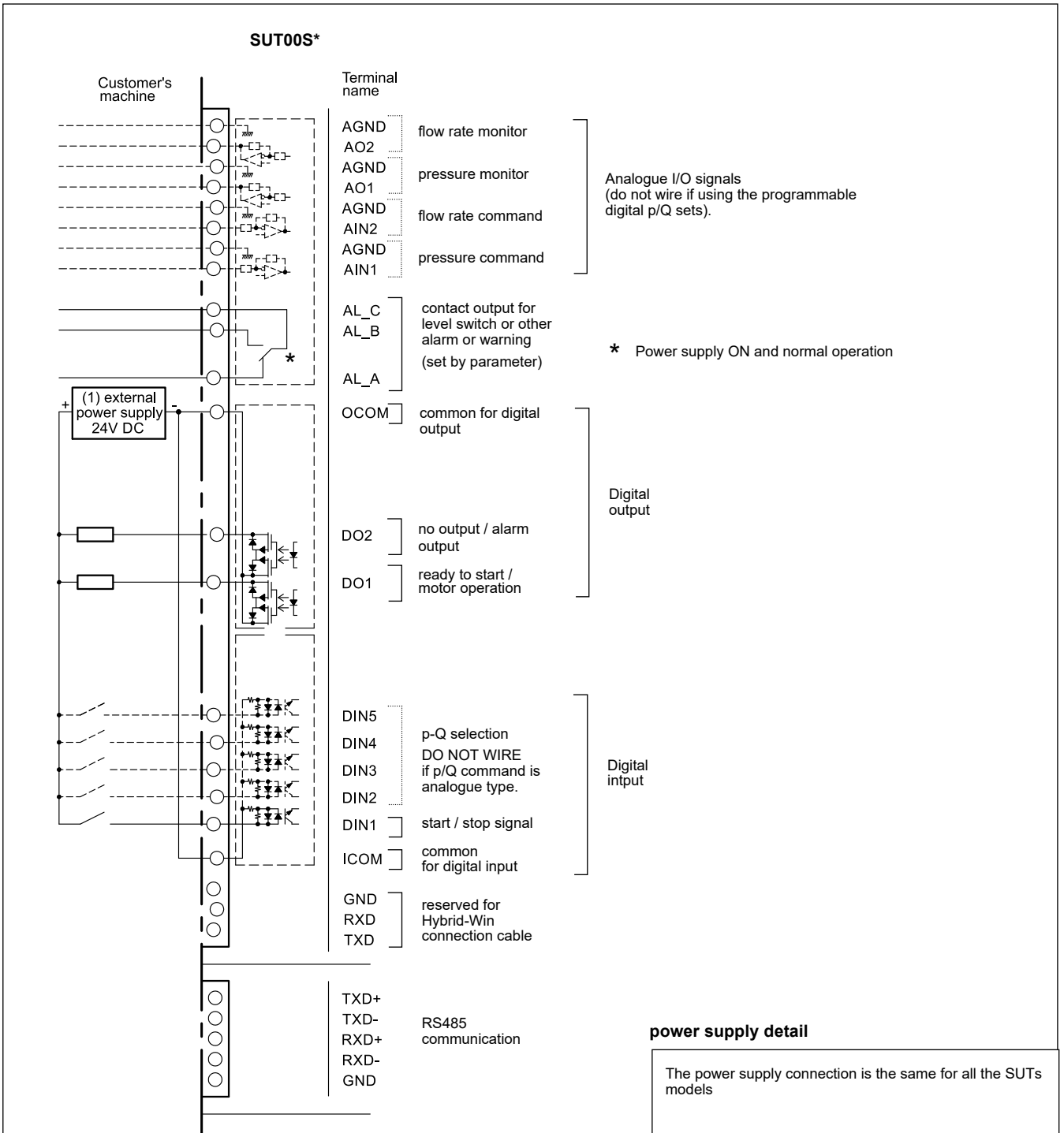

**NOTE:** The type of the desired target PQ signal (external analog command or set of preset pQ points) is set by means of the P67 parameter.

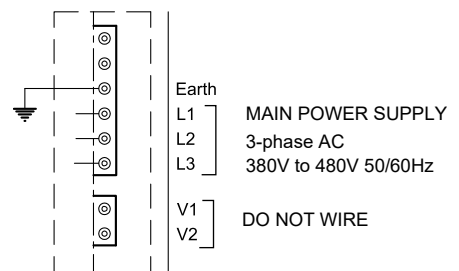

### 9.6 - SUT00D\* Wiring diagrams

SUT00D\* are factory set for autonomous pump switching. In this configuration, the SUT can operate either with analogue signals or with digital pre-set p/Q signals.

In order to operate the pump switching by the external command from the main machine, connect the external command to the DIN6 of the SUT. Then, configure the P70 parameter again. The DIN6 that can be set as ON or OFF (depending on the customer's choice) to obtain the single or the combined operation. Either way, the solenoid valve switching signal will output on pin DO3.

The relay in the machine tool cabinet and the related wiring, from DO3 output of the SUT to the coil of the solenoid valve is in the Customer's charge.

Relay requirements: 24V DC (max 50 mA) coil, single stable, with diode coil surge killer, 24V DC 5A / 220V AC 5A contact rating.

Please refer to the *PIM00693 Instruction Manual* for parameter setting options and digital p/Q setting management.

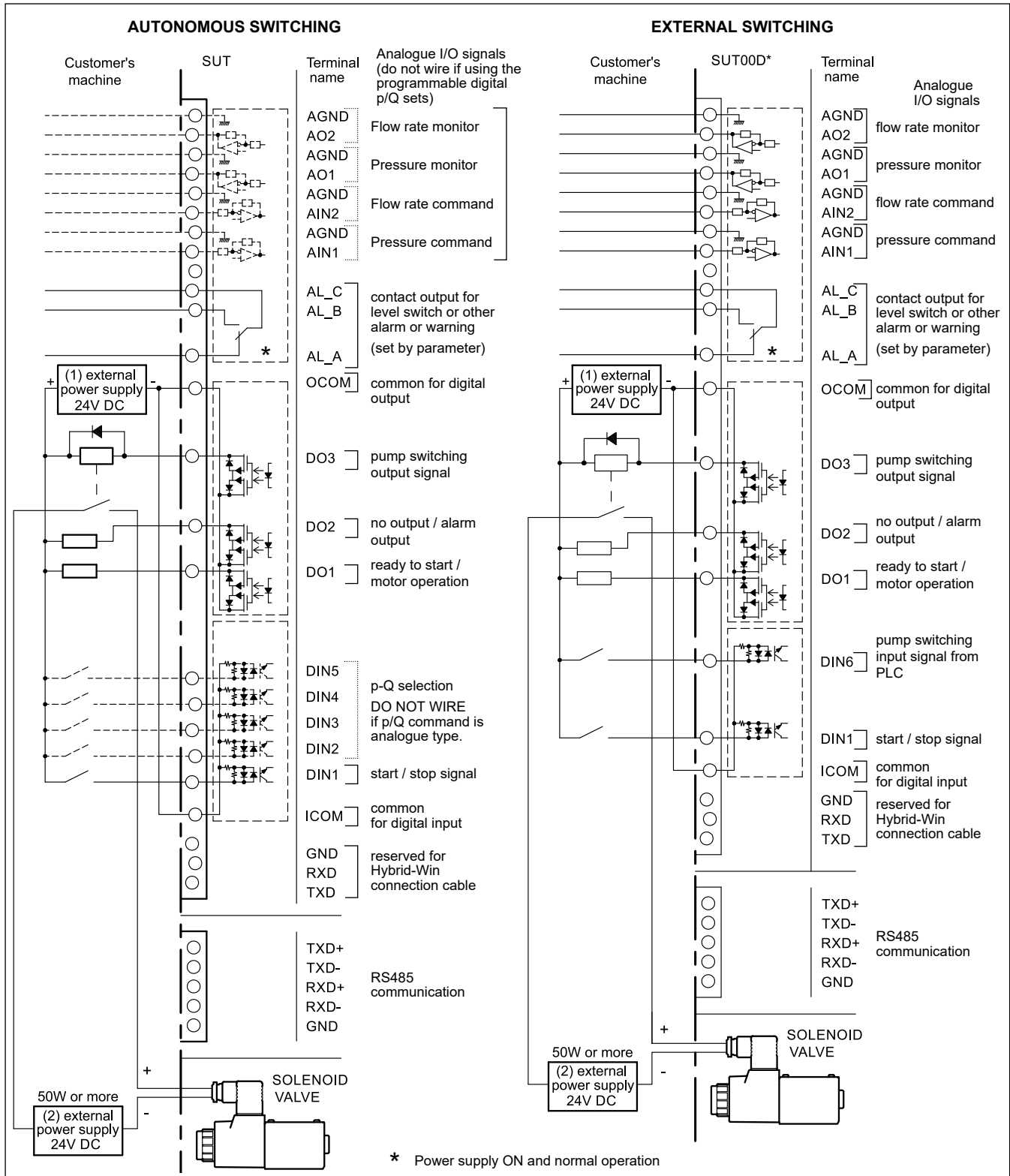

## 9.7 - Digital I/O & alarm signals

terminal	description	value	function / notes
AGND	analogue output: flow rate monitor	0V GND	- QMAX ÷ QMAX (value can be modified by parameter)
AO2		± 10 V	
AGND	analogue output: pressure monitor	0V GND	0 ÷ PMAX
AO1		0 ÷ 10 V	
AGND	analogue input: flow rate command	0V GND	0 ÷ QMAX
AIN2		0 ÷ 10 V	
AGND	analogue input: pressure command	0V GND	0 ÷ PMAX
AIN1		0 ÷ 10 V	
A5V			Unused
AL_C	common alarm output C	switching 30 V DC 0.5 A resistive (min load 10 mV DC 10 µA approx)	Alarm common terminal
AL_B	alarm output B		Connected to the common terminal when the pressure switch is activated, or alarm signal or warning signal output (set by parameter)
AL_A	alarm output A		Connected to the common terminal during normal operation
OCOM	common digital output	24 V DC (±1V, 0.5 A) I max 50 mA / channel resistive	Can be either positive or negative
DO7	digital output 7		Unused
DO6	digital output 6		
DO5	digital output 5		
DO4	digital output 4		
DO3	digital output 3		
DO2	digital output 2		Factory setting: no output. Can be set as alarm output.
DO1	digital output 1		Operation completed or motor running (set by parameter)
DIN8	digital input 8		24 V DC (±10%) I max 5 mA / channel resistive
DIN7	digital input 7		
DIN6	digital input 6	Pump selection signal from PLC. <b>Wire only in external switching mode for SUT00D*.</b>	
DIN5	digital input 5	Programmable digital p/Q point set Up to 16 p/Q points can be set combining the digital inputs.	
DIN4	digital input 4		
DIN3	digital input 3		
DIN2	digital input 2	<b>Not available if external input signal mode is selected.</b> Refer to the Instruction Manual for details.	
DIN1	digital input 1		start/stop signal. Factory set as: Start = OFF / stop = ON (set by parameter)
ICOM	common digital input		Can be either positive or negative

## 9.8 - Communication ports

terminal	description	function / notes
GND	digital ground	RS232C communication Hybrid-Win utility port
RXD	received data	
TXD	transmit data	

terminal	description	function / notes
TXD+		unused
TXD-		
RXD+	data+	RS485 communication main machine / PLC port
RXD-	data-	
GND	digital ground	

## 10 - INSTALLATION NOTES

### 10.1 - Installation and piping

- The SUT is a stationary hybrid unit. It should be bolted to a flat, vibration-free surface, indoor.
- Ensure that there is at least 100 mm clearance around the unit from any obstructions that may obstruct air intake and exhaust. Install the unit in a location with good air flow so that the heated air can be exhausted.

### 10.2 - Hydraulic fluid

- Use mineral-oil base hydraulic fluid. Use of hydraulic fluids other than mineral-oil based type (e.g., hydrous/synthetic) is prohibited.

### 10.3 - Other precautions

- **To ensure correct operation of the SUT, there must be no valves with open-centre spools in the rest position within the actuator motion control circuit, both on the SUT manifold side and on the customer's side.**
- In the event of a hydraulic unit failure, the system will show an alarm and shut down. If such a failure or malfunction could result in death or pose a danger to human beings, take appropriate safety measures in the facilities.
- Turning the power supply ON/OFF frequently will significantly shorten the life of the controller. Use the start/stop digital inputs to start/stop this hydraulic unit. Leave an interval of at least 5 minutes between operation stops invoked by turning the power supply ON/OFF. Also, when starting and stopping the unit using the start/stop signals, leave an interval of at least 0.5 seconds between a stop command and restarting.
- This hydraulic unit takes approximately 3 seconds to start-up after being powered ON. Depending on the piping conditions, the unit may take longer to increase the pressure to the pressure switch's preset level, resulting in pressure switch signal output. In this case, set the machine up so that it will not accept this alarm output during this period.

## 11 - DEVICE SETUP

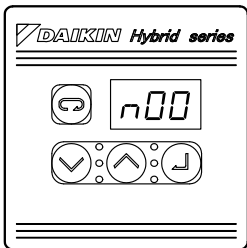

The SUT hybrid unit communicates with the machine using the Modbus-RTU protocol. Configuration of the communication and the hybrid unit can be done from the SUT's operating panel or via software. To configure via software, connect a device with the Hybrid-win software installed to the CN4 port of the SUT located in the unit's control panel, using the appropriate cable kit.

### 11.1 - Hybrid-win software

The software's graphical interface enables real-time monitoring of operating data, parameter reading and setting, and tracking of alarm and warning history.

The Hybrid-Win software is compatible with Microsoft Windows OS. To connect the Hybrid SUT to a PC, a cable connection kit is required. the kit can be ordered separately (see catalogue 96501 SUTPC).

The Hybrid-Win software can be downloaded from the Diplomatic MS website, from the product page.

### 11.2 - Additional documentation

The *Instruction Manual PIM00693* provides instructions about commissioning, SUT configuration and communication protocol towards the main machine. Our Customers can download this manual both from the Reserved Area and from the Product Page of the Diplomatic MS website, using their own account.



## 12 - ACCESSORIES

These accessories are supplied spare. Their arrangement on the SUT is in the Customer's charge.

ordering code	description
3906500002	PM-SPD01 - Surge protection device for EHU#-40/SUT#-40
3906510011	PM-SNF06 - Noise filter for SUT#-40
3906510010	SUTPC/10 - Kit for Hybrid-Win software connection
3906500015	LS-B12-140/10-D24K1-SPDT - Level switch SPDT 1/2" BSPP ( <b>NOTE</b> )
3906500012	TS-B12-170-60/10-D24K1-SPDT - Temperature switch 1/2" BSPP - 24V DC switching temperature 60 °C
1561531	P4DL-P/10N - Modular subplate with ISO 4401-05 mounting surface + NBR coupling O-Ring
1561541	P4DL-D3P/10N - Modular subplate with ISO 4401-03 mounting surface + NBR coupling O-Ring
3906510020	Suction flange kit 1" BSPP for SUT00D6021 and SUT00D8021

**NOTE:** This device is already installed on all the SUT units with tank. It is available as a spare part.



**SUT**  
SERIES 40

**DUPLOMATIC**  
MOTION SOLUTIONS  
*a member of **DAIKIN** group*

**DUPLOMATIC MS Spa**

via Mario Re Depaolini, 24 | 20015 Parabiago (MI) | Italy  
T +39 0331 895111 | E vendite.ita@duplomatic.com | sales.exp@duplomatic.com  
duplomaticmotionsolutions.com