



# AKW

## COOLING UNITS FOR WATER-BASED FLUIDS SERIES A

### DESCRIPTION

The AKW cooling unit series achieves high energy-saving performance thanks to its built-in DAIKIN original IPM motor inverter controlled. The IPM motor allows for very accurate temperature control. The power consumption can be monitored on the control panel. The AKW cooling units are available as basic or configurable models, with pump and tank either integrated or external.

These cooling units can control the temperature in three ways:

- Set the fluid temperature according to the ambient temperature or to the machinery temperature
- Hold the fluid temperature constant
- Cool the fluid at constant cooling capacity

An auto-tuning function that automatically sets the control gain according to the system installed (water volume in the tank, piping, etc.) reduces adjustment time significantly at the trial run.

The AKW cooling units are perfect in applications that demand a strict control of the temperature, such as machining centres, NC lathes, semiconductor production equipment, laser cutting machines/laser oscillators, electrical discharge machines, beam welding machines and medical equipment.

### MAIN CHARACTERISTICS

Cooling capacity 50/60 Hz ( <b>NOTE</b> )	kW	1.8 ÷ 9.2 (see detailed specifications at pp. 2, 11 and 17)
Accuracy of the temperature control	°C	±0.1 (load range from 0% to 100%)
Supply power voltage main circuit operating circuit		three-phase 400 V AC 50/60Hz (±10%) 12/24 V DC
Power consumption (400V 50/60Hz)	kW	0.81 ÷ 4.59 (see detailed specifications at pp. 2, 12 and 18)
Current consumption (400V 50/60Hz)	A	1.6 ÷ 9.3 (see detailed specifications at pp. 2, 12 and 18)
Admitted fluids		purified water for industrial purpose , ethylene glycol emulsion (30 vol% or less)
Ambient operating temperature	°C	+5 to +45
Evaporator outlet liquid temperature	°C	+5 to +45
Refrigerant gas		R410A contained in a hermetically sealed circuit
Relative humidity range	%RH	20 ÷ 85
Protection class Electric component housing		IP2X IP54 with proper cable glands and connectors

**NOTE 1:** The cooling capacity is the value at standard point (outlet liquid temperature: 25 °C, ambient temperature: 25 °C, liquid used: water, rated circulation rate, 1 atm). The product tolerance is approx. ±5%.

**1 - IDENTIFICATION CODE FOR BASIC MODELS, WITHOUT PUMP AND WITHOUT TANK**

**NOTE:** Models with pump and tank are illustrated starting from page 12.

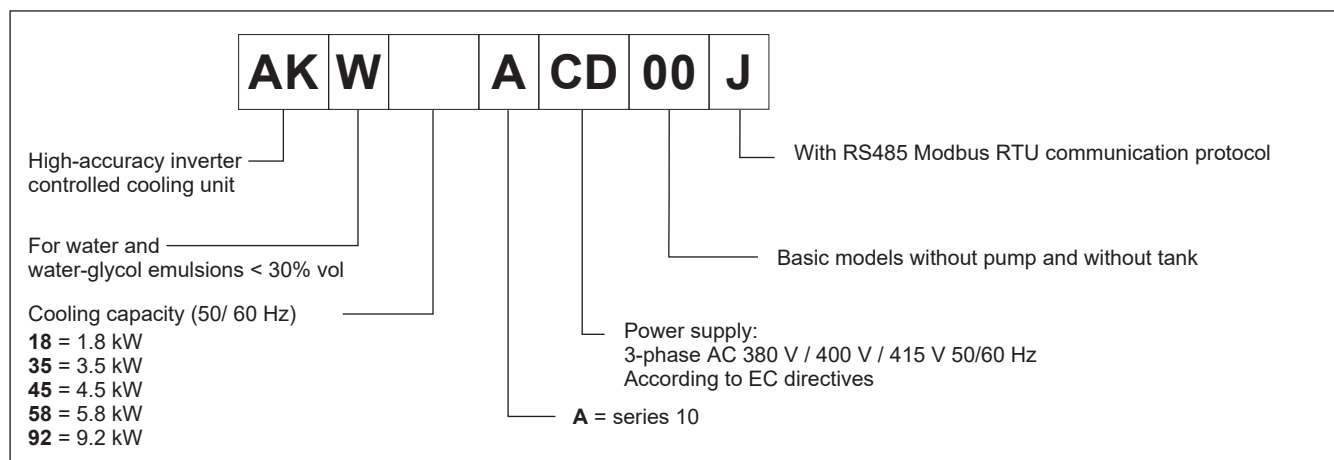
**2 - SPECIFICATIONS FOR BASIC MODELS, WITHOUT PUMP AND WITHOUT TANK**

		AKW18	AKW35	AKW45	AKW58	AKW92
Cooling capacity (NOTE 1)	kW	1.8	3.5	4.5	5.8	9.2
Supply power		3-phase AC 380/400/415 V 50/60 Hz				
Supply voltage main circuit control circuit		3-phase AC 380/400/415 V 50/60 Hz 12/24 V DC				
Max power consumption (400V 50/60 Hz)	kW	0.81	1.36	1.60	2.40	3.84
Max current consumption (400V 50/60 Hz)	A	1.6	2.6	3.0	4.3	7.5
Compressor (hermetic DC swing type)	kW	0.4 max	0.75 max	1.1 max	1.5 max	2.2 max
Evaporator		brazed plate type				
Condenser		cross-fin coil type				
Propeller fan motor		Ø240, 54 W	Ø300, 54 W		Ø400, 100 W	Ø455, 100 W
Refrigerant control		Compressor rotation control via inverter + electronic expansion valve opening				
Refrigerant gas R410A (NOTE 2) filling q.ty CO <sub>2</sub> equivalents	kg	0.56 1.18	0.79 1.66	0.84 1.76	1.02 2.14	1.42 2.97
Cooling fluid withstand pressure	bar	5			10	
Circulating volume rated range	l/min	10 6 ÷ 15	15 10 ÷ 20	15 10 ÷ 30	25 13 ÷ 30	40 25 ÷ 45
Noise level (front 1 m, height 1.55 m)	dB(A)	60	61	62	65	67
Applicable liquid		purified water for industrial purpose, ethylene glycol emulsion (30 vol% or less)				
Exterior colour		Ivory white				
Transportation weight	kg	38	43	44	70	88
ELCB (mandatory, in the customer's charge)	A	10			15	20

**NOTE 1:** Cooling capacity is the value at standard point (outlet liquid temperature: 25 °C, ambient temperature: 25 °C, liquid used: water, rated circulation rate, 1 atm). The product tolerance is approx. ±5%.

**NOTE 2:** The R410A refrigerant is contained in a full hermetical circuit. The SDS (Safety Data Sheet) for R410A refrigerant is provided. GWP: 2090. 'Global Warming Potential' (GWP) means the measure of how much 1 kg of the refrigerant applied in the vapour compression cycle is estimated to contribute to global warming, expressed in kg CO<sub>2</sub> equivalents over a 100-year time horizon.

### 3 - TEMPERATURE CONTROL MODES

The AKW cooling units can control the temperature of the fluid in three different modes, thanks to the thermistors located along the liquid circuit.

- Set the fluid (water) temperature according to the ambient temperature (standard mode).  
Control is done by keeping a constant temperature difference between the evaporator outlet liquid temperature and the ambient temperature. The AKW58 and AKW92 cooling units, unlike other models, are equipped with a thermistor at the evaporator inlet and are therefore factory-set using the inlet liquid temperature as a reference. By installing optional thermistors on the machinery or on the liquid piping, other control modes are possible.  
The setting range is  $\pm 9.9$  °C against the reference temperature.
- Hold the fluid (water) temperature constant:  
Control is done by keeping a control target at a constant temperature.  
The setting range is  $5 \div 45$  °C
- Cool the fluid at constant capacity  
The temperature control is disabled. Cooling is based on the cooling capacity, set via the control command. This mode is useful during commissioning, maintenance, etc.  
The setting range is  $0 \div 100\%$ .

Some operating modes require an additional thermistor to be installed directly on the machinery to be cooled or positioned along the fluid circuit. These thermistors must be ordered separately, and their installation is the responsibility of the customer. See point 23.

The operating mode can be selected from the control panel. For detailed information, please refer to the *Instruction Manual* provided with the cooling unit.

### 4 - SYSTEM OUTLINE

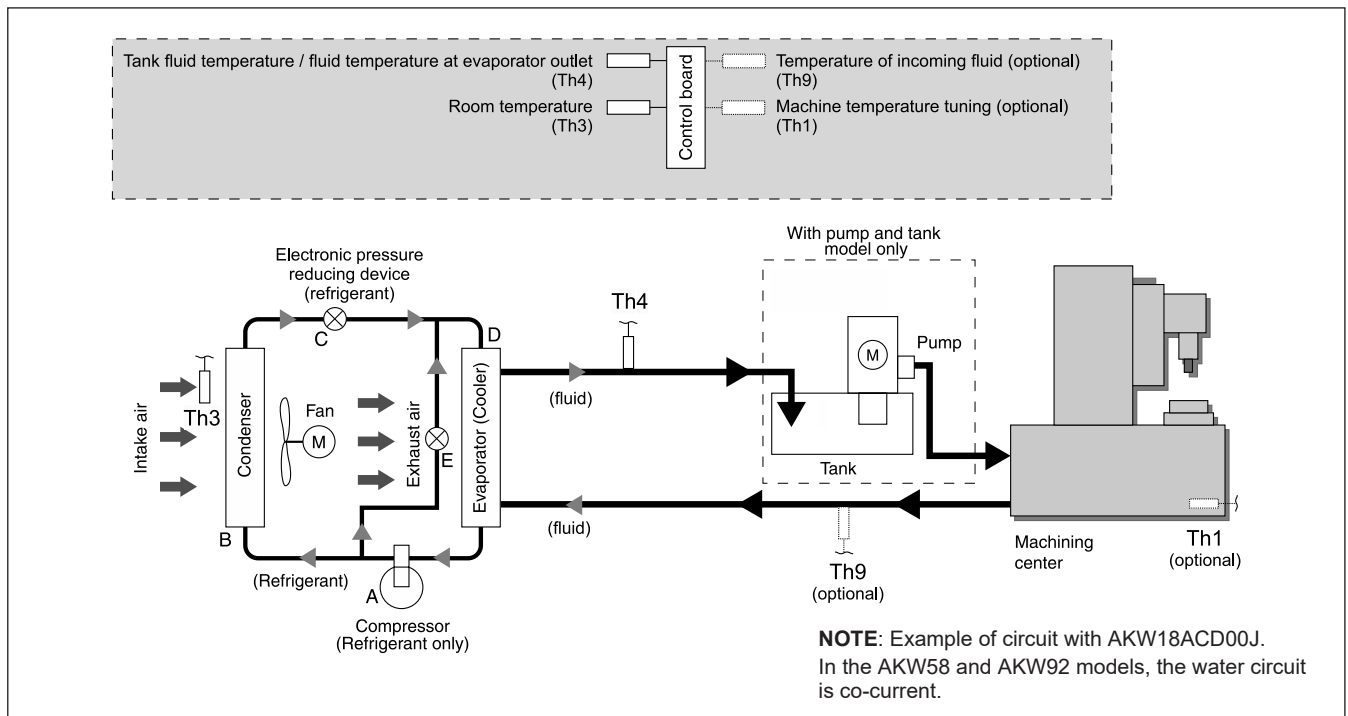

#### 4.1 - Refrigeration cycle

- The compressor compresses the refrigerant gas, increasing both its pressure and temperature. The gas, now at high pressure and high temperature, flows towards the condenser.
- In the condenser, the high-temperature, high-pressure gas releases heat to the surrounding environment. As it cools, the gas begins to condense, turning into a high-temperature, high-pressure liquid.
- The pressure reduction mechanism regulates the fluid's density to maximize efficiency during the subsequent passage through the evaporator, ensuring the refrigerant can absorb heat optimally.
- In the evaporator, the low-temperature, low-pressure liquid/gas mixture evaporates, absorbing heat from the liquid (cooling it), and transforming it into a low-temperature, low-pressure gas
- For very low load, the hot gas bypass valve automatically regulates the cooling capacity adding high temperature, high pressure gas to the mixture in order to achieve the correct proportion of gas/mixture at evaporator inlet.

#### 4.2 - Fluid circuit

The fluid to be cooled comes from the machine directly into the evaporator. The cooled fluid is delivered to the machining center (pump and tank are supplied or they are in the customer's charge, according to the purchased model).

## 5 - CIRCUIT DIAGRAM

### 5.1 - Basic model

In the AKW58 and AKW92 models, the water circulates co-current with the refrigerant circuit, and a thermistor is also present on the inlet piping.

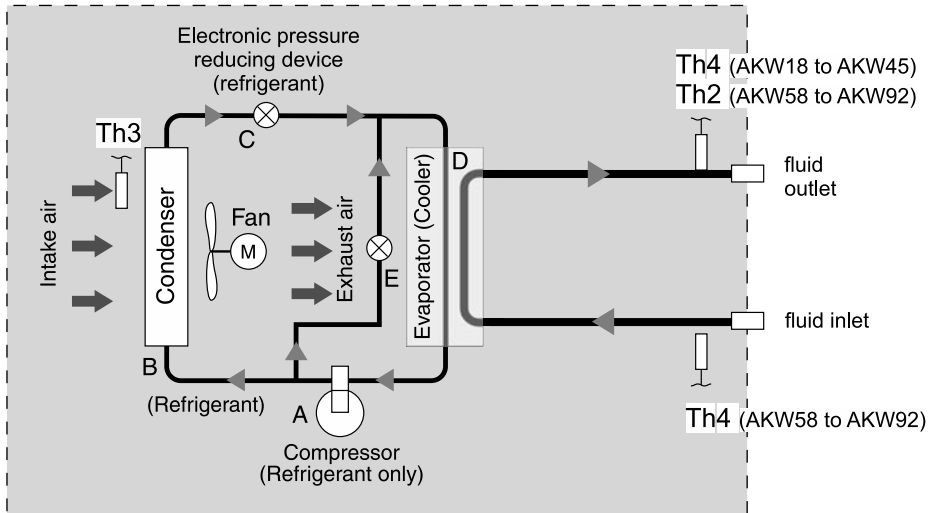

## 6 - OPERATING TEMPERATURE RANGE

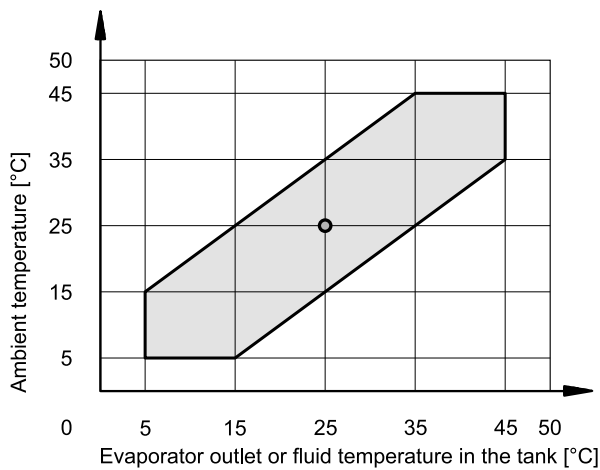

- Admissible operating temperature range. Operation outside of this range may cause unit failure.
- Standard point (H<sub>2</sub>O temperature and ambient temperature 25 °C)



**6.1 - Applicable fluids**

Use only industrial purified water that meets the standards specified below (including the dilution of the ethylene glycol solution).

The water quality guidelines were established by the Japan Refrigeration and Air Conditioning Industry Association (JRAIA) in the document JRA-GL-02-1994.

Although the parameters meet the water quality requirements, total prevention of corrosion cannot be guaranteed.

	Item		Unit	Standard Value	Tendency	
					Corrosion	Scale Generation
Standard parameters	pH (25°C)		-	6.0 to 8.0	■	■
	Electrical conductivity (25 °C)		mS/m	max 30	■	■
	Chloride ion	Cl <sup>-</sup>	mg/l	max 50	■	
	Sulfate ion	SO <sub>4</sub> <sup>2-</sup>		max 50	■	
	Acid consumption (pH 4.8)	CaCO <sub>3</sub>		max 50		■
	Total hardness	CaCO <sub>3</sub>		max 70		■
	Calcium hardness	CaCO <sub>3</sub>		max 50		■
	Ionic silica	SiO <sub>2</sub>		max 30		■
Iron	Fe	mg/l		max 0.3	■	■
Copper	Cu		max 0.1	■		
Sulfate ion	S <sup>2-</sup>		not to be detected	■		
Ammonium ion	NH <sup>4+</sup>		max 0.1	■		
Residual chlorine	Cl		max 0.3	■		
Free carbon dioxide	CO <sub>2</sub>		max 4.0	■		

## 7 - CHARACTERISTICS OF THE BASIC MODELS, WITHOUT PUMP AND WITHOUT TANK

Values obtained and rated for standard point. Fluid used: H<sub>2</sub>O.

### 7.1 - Temperature control

Cooling capacity (kW) according to the ambient temperature.

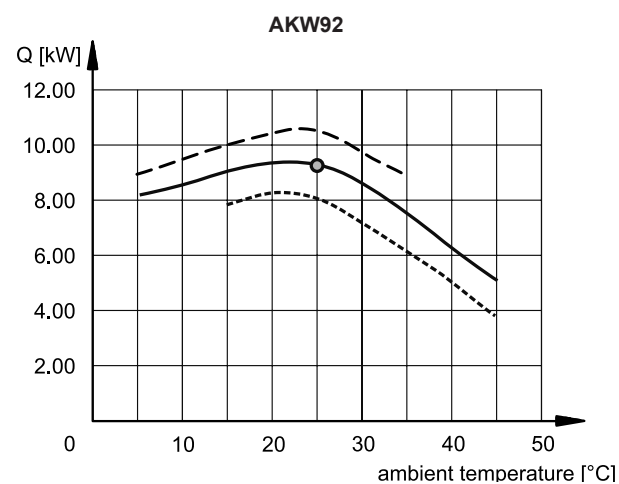
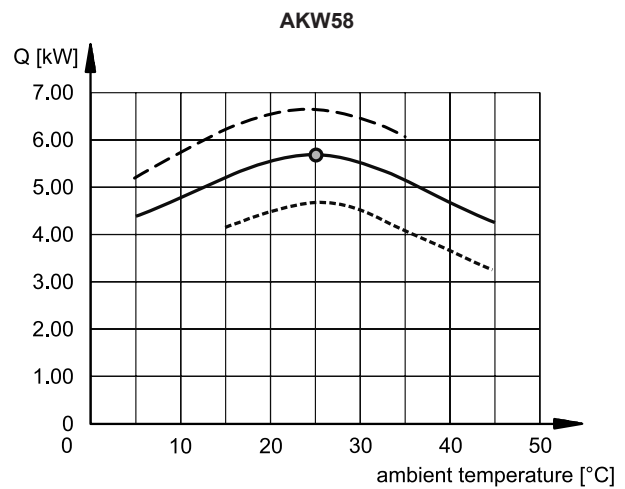
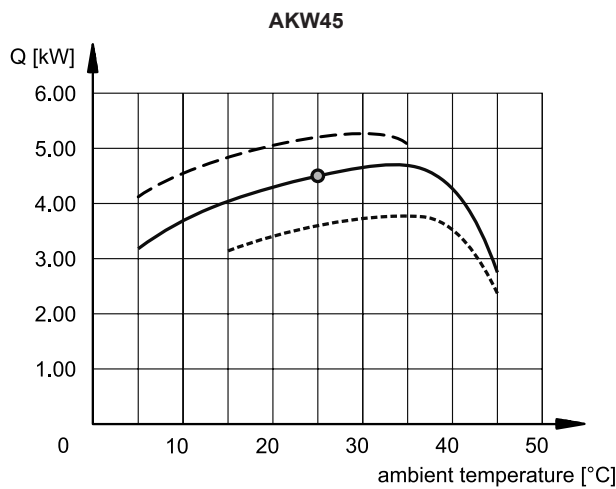
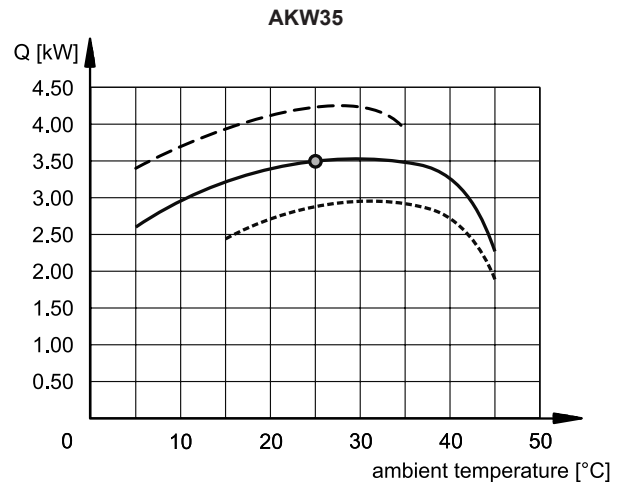
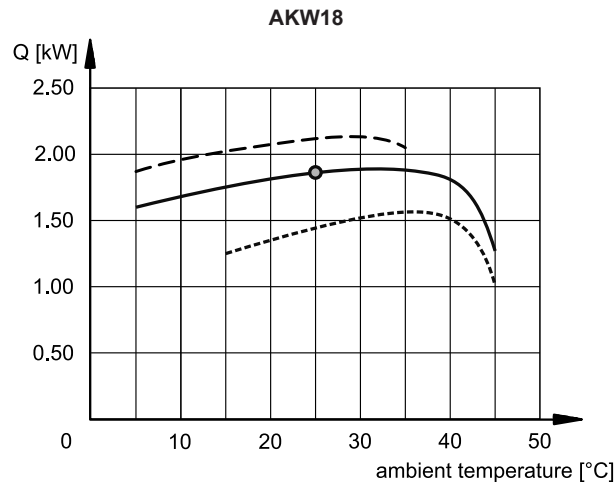

- H<sub>2</sub>O temperature = ambient temperature
- - - H<sub>2</sub>O temperature = ambient temperature + 10 °C
- · · H<sub>2</sub>O temperature = ambient temperature - 10 °C
- standard point (H<sub>2</sub>O temperature and ambient temperature 25 °C)

## 8 - OVERALL DIMENSIONS AND MOUNTING - BASIC MODELS, WITHOUT PUMP AND WITHOUT TANK

### 8.1 - AKW18ACD00J, AKW35ACD00J and AKW45ACD00J

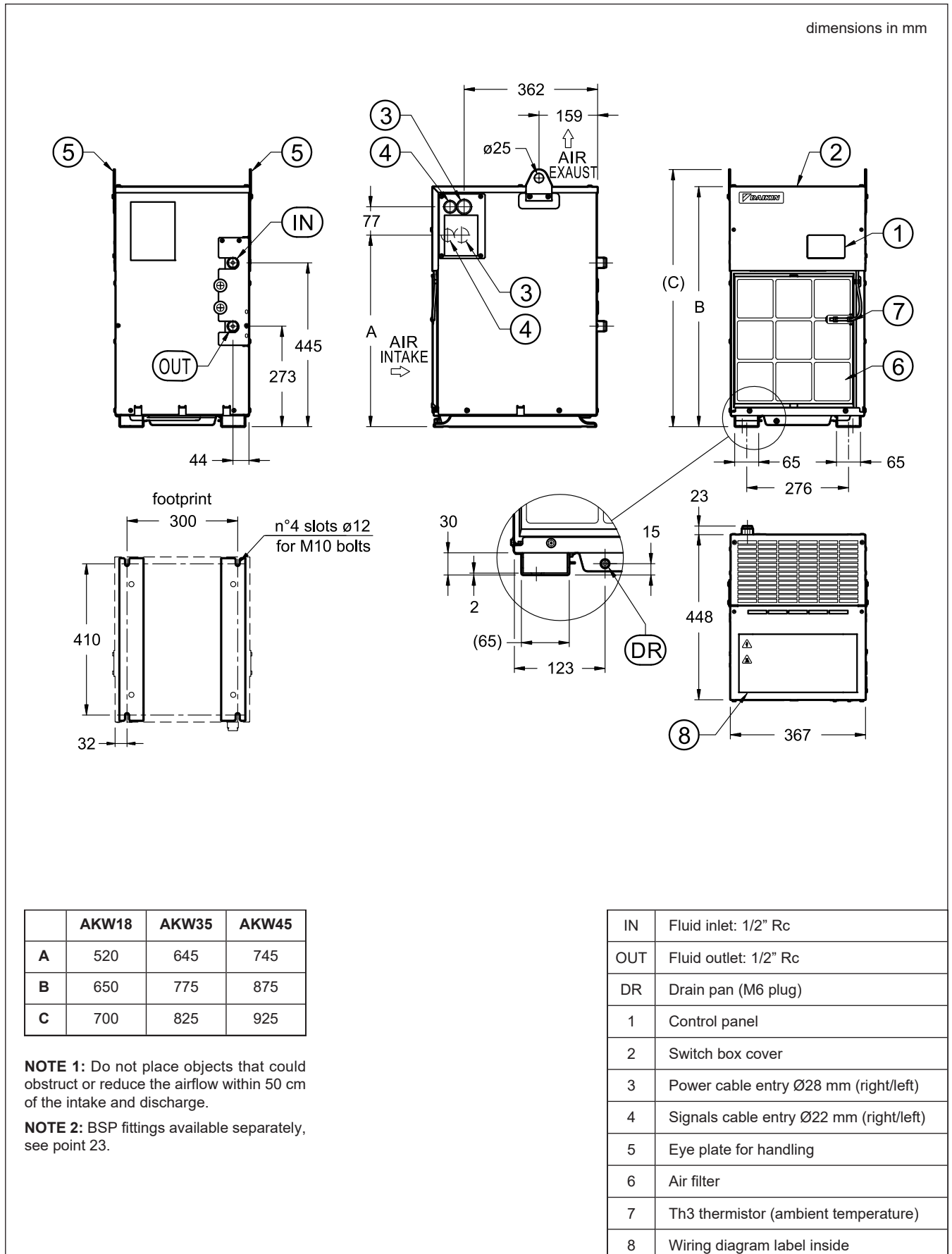

8.2 - AKW58ACD00J

dimensions in mm

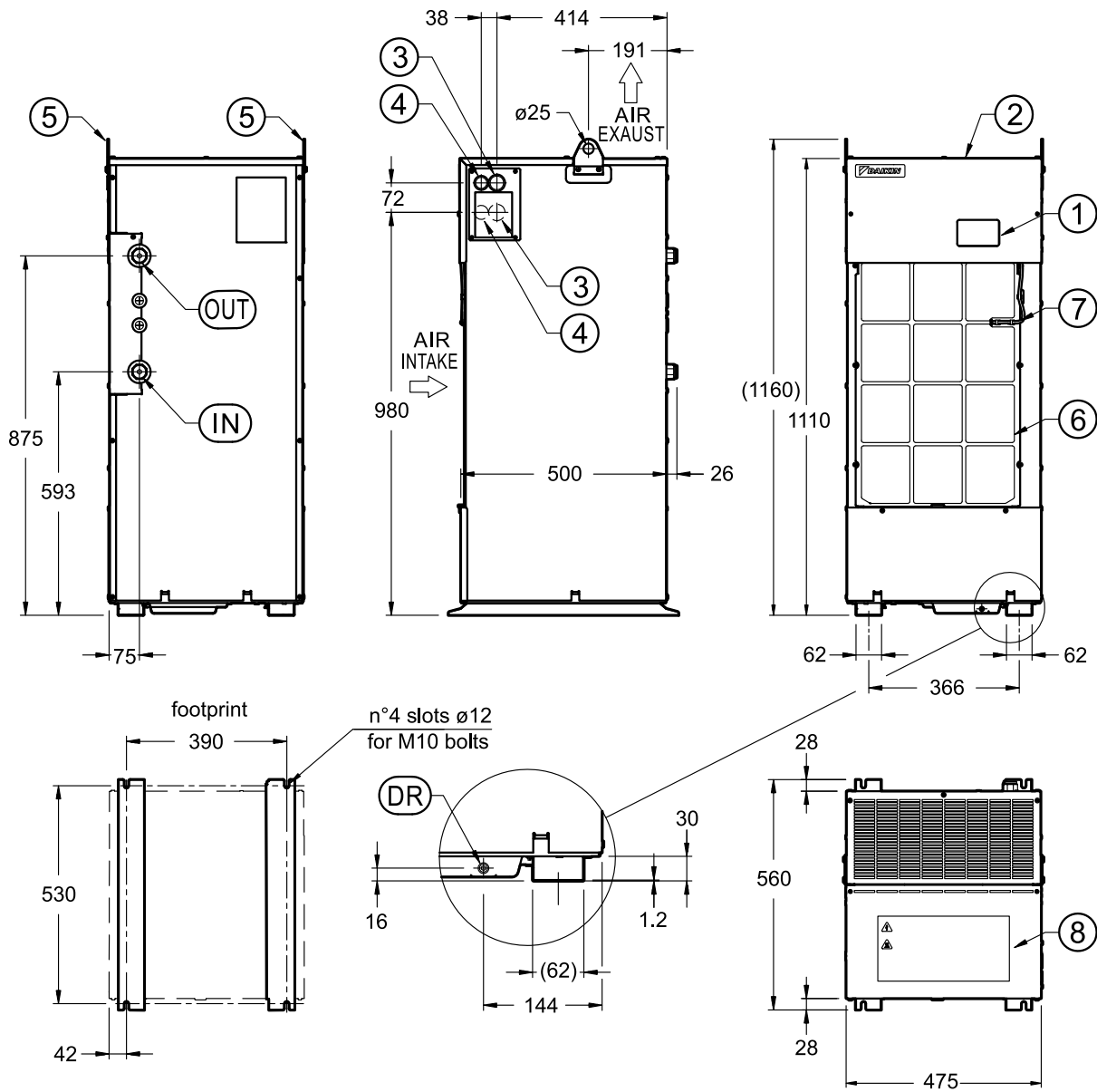

**NOTE 1:** Do not place objects that could obstruct or reduce the airflow within 50 cm of the intake and discharge.

**NOTE 2:** BSP fittings available separately, see point 23.

IN	Fluid inlet: 3/4" Rc
OUT	Fluid outlet: 3/4" Rc
DR	Drain pan (M6 plug)
1	Control panel
2	Switch box cover

3	Power cable entry Ø28 mm (right/left)
4	Signals cable entry Ø22 mm (right/left)
5	Eye plate for handling
6	Air filter
7	Th3 thermistor (ambient temperature)
8	Wiring diagram label inside

8.3 - AKW92ACD00J

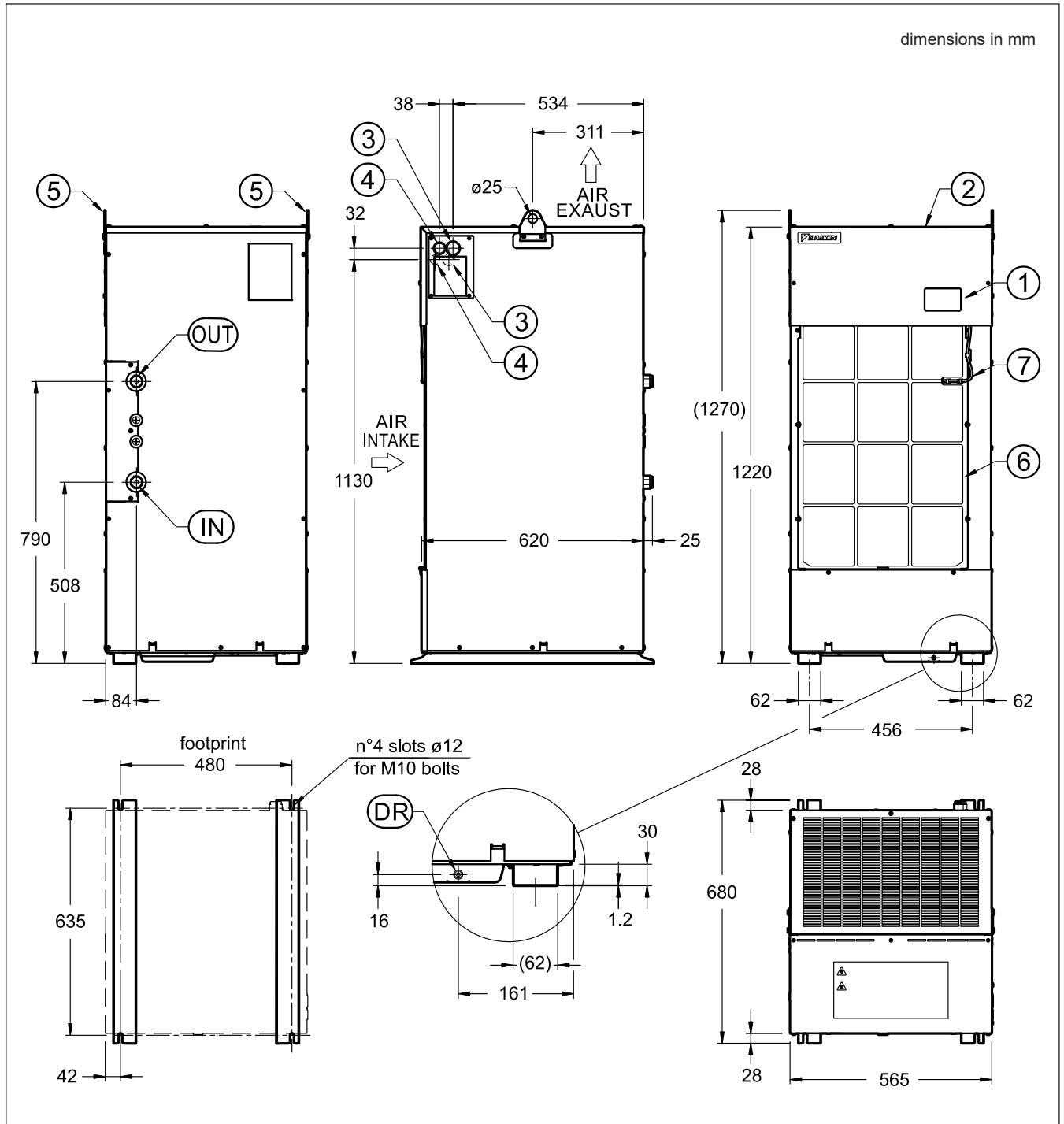

**NOTE 1:** Do not place objects that could obstruct or reduce the airflow within 50 cm of the intake and discharge.

**NOTE 2:** BSP fittings available separately, see point 23.

IN	Fluid inlet: 3/4" Rc
OUT	Fluid outlet: 3/4" Rc
DR	Drain pan (M6 plug)
1	Control panel
2	Switch box cover

3	Power cable entry $\varnothing 28$ mm (right/left)
4	Signals cable entry $\varnothing 22$ mm (right/left)
5	Eye plate for handling
6	Air filter
7	Th3 thermistor (ambient temperature)
8	Wiring diagram label inside

## 9 - EMC 2014/30/EU COMPLIANCE

The AKW cooling units are classified as auxiliary machines of over-voltage category II, main machine. Install a main power switch as required by EN60204-1 on the control panel of the main machine. Carry out power supply through a transformer provided with basic insulation (IEC Code 60335-1)



Be sure to connect the earth leakage circuit breaker (ELCB) of specified capacity (to be prepared by the customer) to the main power. (Other measures against earth leakage must be taken when using the moulded case circuit breaker (MCCB)).



Be sure to install an earth conductor. Due to a noise filter being mounted, there is a danger of electrical shock unless earth connection is provided.



Be sure to disconnect power supply before opening the cover of the electrical panel. **Leave it out for 5 minutes**, waiting for the discharge of the internal high voltage to be completed. Do not connect power supply while the electrical equipment box is open.

To avoid the effects of potential electrical interference, cut the power cable to an appropriate length, ensuring that excess wire does not come into contact with the control circuit board or other components.

## 10 - WIRING

To proceed with the wiring of the electrical parts, open the cover, taking care to keep the special screws that seal it and not to damage the gasket located on the edge of the cover. The screws will be reused to close it at the end of the wiring.

**Use cables with an IP54 protection rating or higher for the incoming wiring, so that the electrical panel maintains a protection rating equivalent to IP54.**

The customer must wire: main power supply (X1M), pump (K1S), signals (X2M), and communication with the main machine (X3M).



Refer to the *Instruction Manual* and the *PIM00605B\_Modbus Communication Function Instruction Manual\_EN* for wiring details.

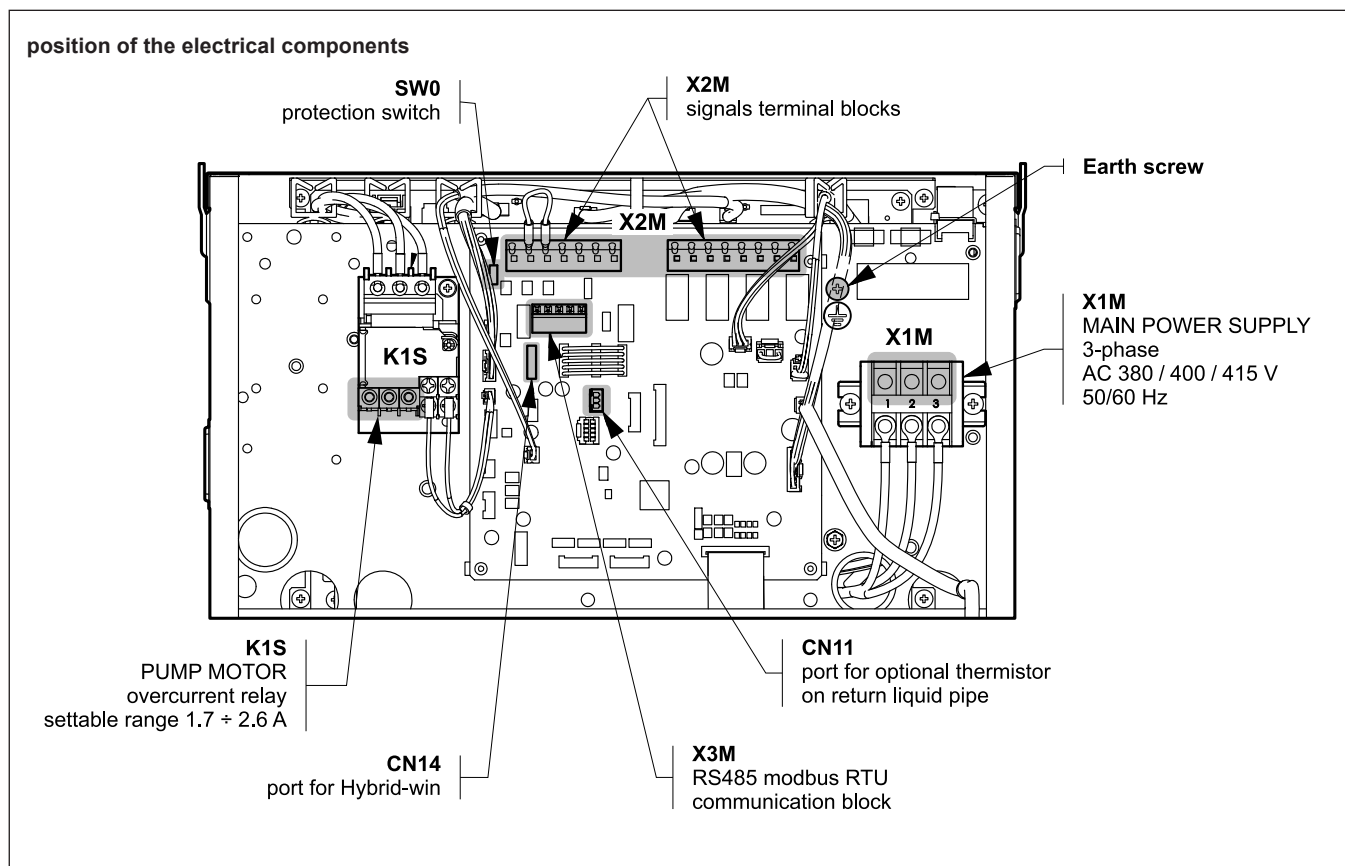

### 10.1 - Earth Screw

Connect the earth cable to the earth terminal. Use a green/yellow earth cable.

### 10.2 - Main Power Supply (X1M)

AKW92: M5 screw terminal. Use 4-core cables with a cross-point of  $\geq 4 \text{ mm}^2$ .

Other models: M4, M5 screw terminal. Use 4-core cables with a cross-point of  $\geq 2.5 \text{ mm}^2$ .

### 10.3 - Pump Motor (K1S)

M3.5 screw terminals. Use ring terminals without soldering and cables with a cross-point of  $\geq 1.5 \text{ mm}^2$ .

### 10.4 - Signal Terminal Block (X2M)

Use pin solderless terminal connectors and twisted 2-core cables with a cross-point from 0.5 to 1.5  $\text{mm}^2$ . If using stripped cables, remove 9-10 mm of insulation. Shielded cables are recommended for thermistors with leads longer than 10 m and in areas with electrical noise.

**Wiring of the signal terminal block X2M, customer side**

load	function / notes
NC	Unused
min load: 12 V DC 5 mA	Remote control. Remove the short-circuit wire between [10] and [11] and install an operation switch (customer's charge) The cooler can trigger an alarm upon receiving a signal from external protection devices (e.g. flow switch, level switch). Parameter [n002].
	For thermistors with a cable longer than 15 m and in the case of electromagnetic noise, the use of shielded cables is recommended.
min load: 5 V DC 1 mA max load: 24V 1A	The alarm signal is triggered based on the value set in parameter [n001]. Contact capacity 30 V DC, 2A. Refer to the <i>instruction manual</i> to configure the options
NC	Unused
min load: 5V DC 1 mA max load: 24V 1A	The warning signal depends on the value of parameter [n001], for normal status (RUN), first-level warning (LOCK), second-level warning, and power failure (POWER FAILURE)

### 10.5 - Main Machine Communication (X3M)

This connection with RS485 interface and termination resistor allows data transmission/reception with a host computer, PLC (programmable logic controller), touch screen, etc.

The maximum allowed length for communication wiring is 200 m (total extension). The communication data format is defined according to the Modbus protocol. The cooling unit operates as a slave station.

Please refer to the *Modbus Communication Function Instruction Manual* for detailed information.

### 10.6 - Optional Thermistor Connection on Return Pipe (CN11)

Connect the optional thermistor cable to the CN11 port.

### 10.7 - Error Prevention Switch (SW0)

The AKW cooling units are equipped with an error prevention/protection switch (SW0) to disable settings from the control panel. The default setting for this switch is OFF, but some non-standard units may be set to ON.

## 11 - IDENTIFICATION CODE - CONFIGURABLE MODELS WITH INTEGRATED PUMP AND TANK

	<b>AK</b>	<b>W</b>		<b>A</b>	<b>CD</b>		<b>J / P</b>		-		-	<b>0</b>		-	<b>K****</b>
--	-----------	----------	--	----------	-----------	--	--------------	--	---	--	---	----------	--	---	--------------

High-accuracy inverter controlled cooling unit

For water and water-glycol emulsions < 30% vol

Cooling capacity (50/ 60 Hz)

**18** = 1.8 kW  
**35** = 3.5 kW  
**45** = 4.5 kW  
**58** = 5.8 kW  
**92** = 9.2 kW

**A** = series 10

Power supply:  
 3-phase AC 380 V / 400 V / 415 V 50/60 Hz  
 According to EC directives

Frame model:

For AKW18, AKW35 e AKW45:  
**00** = with pump, with or without tank

For AKW58 e AKW92:  
**00** = with pump, without tank  
**80** = with pump, stainless steel tank.

With RS485 Modbus RTU communication protocol

Project code for customisation (assigned by Diplomatic) **(NOTE 1)**

Other options

Electrical connections  
**0** = to be wired to terminal block  
**S** = with plug-in sockets and external isolator switch

Tank:  
**0** = no tank  
**T** = plastic tank  
**I** = stainless steel tank (available and mandatory only for AKW58 and AKW92)

Pump head:  
**L** = low pressure 2 bar  
**M** = medium pressure 4 bar

Horizontal pump  
**NOTE:** Models with a submerged pump mounted vertically on an external stainless steel tank are also available.  
 See the dedicated point on page 20.

**NOTE 1: Customised Options**

The cooling unit can be customised according to the customer's requirements by liaising with the pre-sales service.

Customisations include the installation of optional protection devices (flow switch, level switch, pressure gauge on pump outlet), castors, Rc / BSP adapter fittings, wiring of optional thermistors supplied by us, and programming different from the factory standard.

Separately available for purchase are: the plug for the Modbus communication socket, adapter fittings, long-life filters, and the cable kit for connection with Hybrid Win software. See catalogue 90 661 - AK\* ACCESSORIES.

**12 - SPECIFICATIONS FOR CONFIGURABLE MODELS WITH INTEGRATED PUMP AND TANK**

**NOTE:** The value refers to the motor pump only. Add this value to the one shown in the specifications table on page 2 to obtain the total power consumption of the chiller. Refer to the same table for any missing specifications.

		AKW18	AKW35	AKW45	AKW58	AKW92
Power supply		Three-phase AC 380/400/415 V 50/60 Hz				
L-type motor pump input power ( <b>NOTE</b> )		0.45 kW / 1 A				
M-type motor pump input power ( <b>NOTE</b> )		0.55 kW / 1.2 A				0.75 kW / 1.8 A
Circulating volume rated range	l/min	10 6 ÷ 15	15 10 ÷ 20	15 10 ÷ 30	25 13 ÷ 30	40 25 ÷ 45
Nominal head 50/60 Hz: L-type pump M-type pump	m	28 / 38 35 / 48	26 / 37 34 / 46	26 / 37 34 / 46	24 / 36 30 / 42	20 / 30 34 / 52
Tank volume: T-type (plastic) I-type (stainless steel)	l	7 -	7 -	7 -	- 15	- 20
Transportation weight: L-type pump M-type pump	kg	58 59	63 64	64 65	92 93	114 119

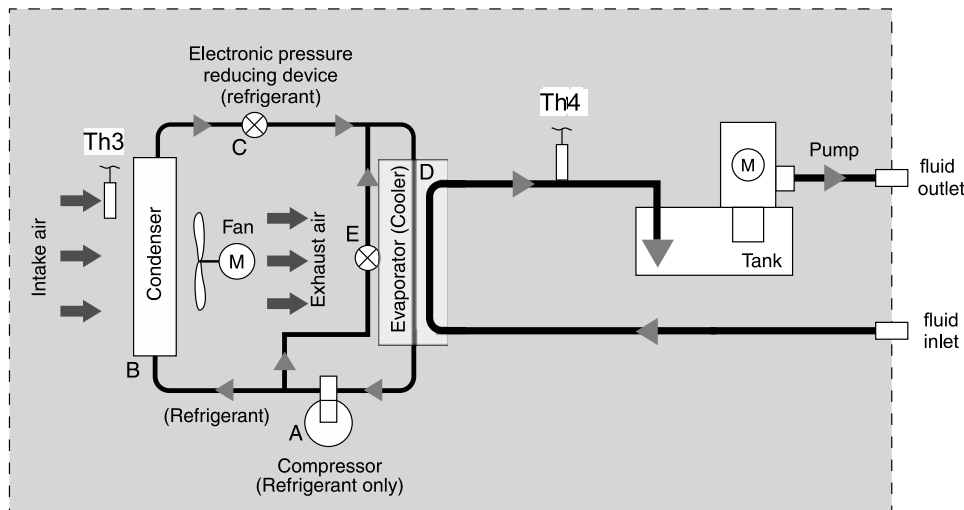
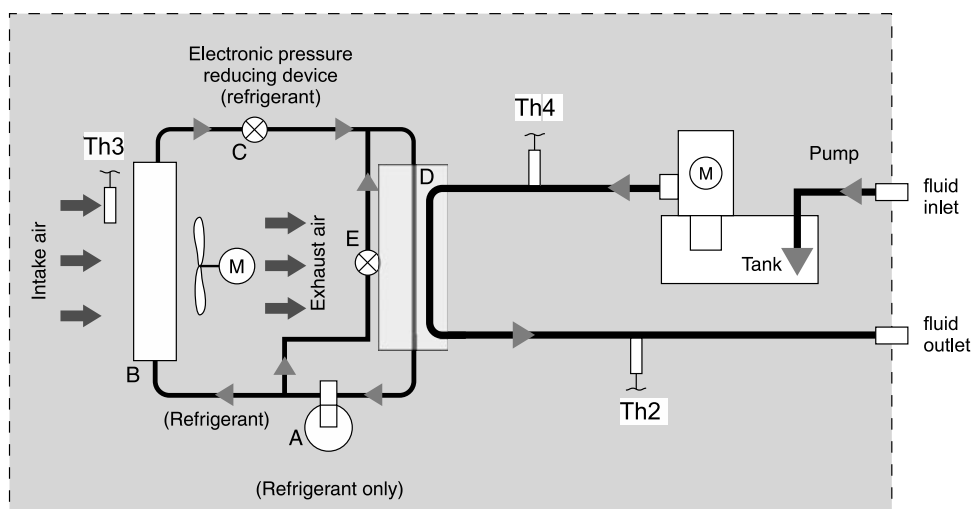
**13 - CIRCUIT DIAGRAM OF CONFIGURABLE MODELS**
**13.1 - AKW18, AKW35 and AKW45**

**13.2 - AKW58 and AKW92**



## 14 - PUMP FLOW RATE CHARACTERISTICS - CONFIGURABLE MODELS WITH INTEGRATED PUMP AND TANK

### 14.1 - L-type pump

The diagrams show the performance curves of AKW chillers with the dual-frequency L-type pump at 50 Hz and 60 Hz, with water as the heat transfer fluid. When using a water-glycol emulsion, the flow rate will be lower at the same head.

Select the pipe diameter and length to keep the circulating flow within the allowable range.

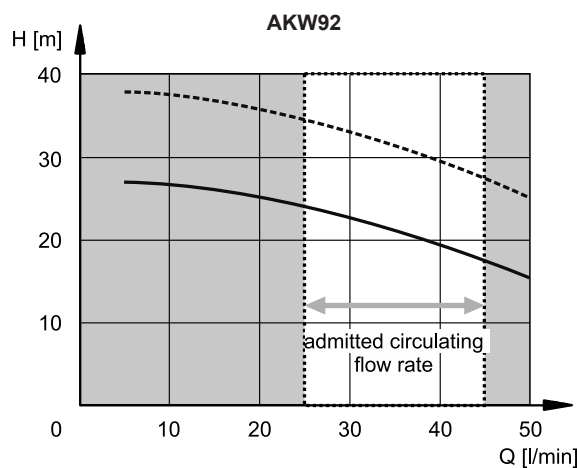
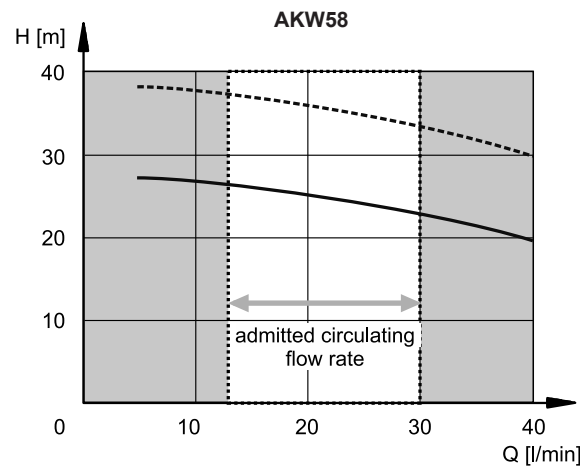
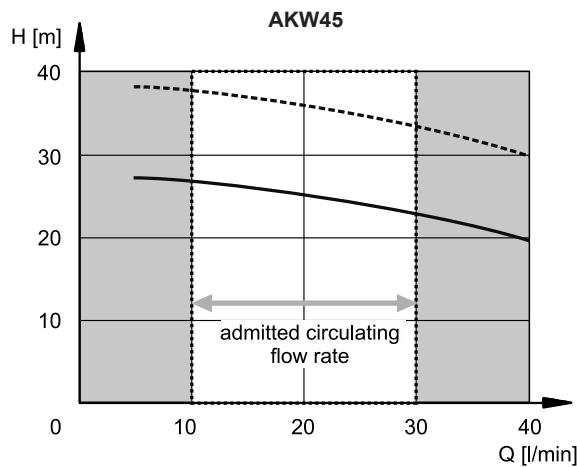
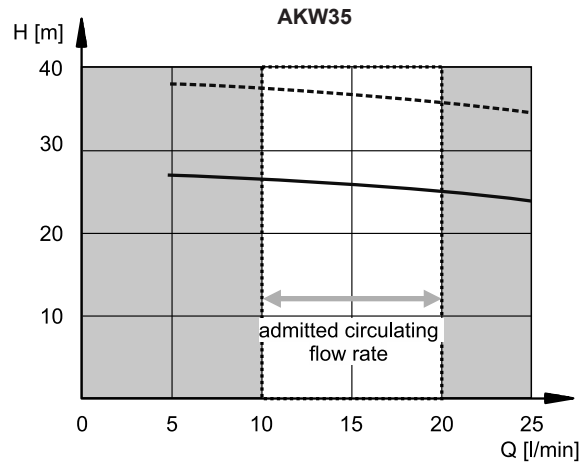
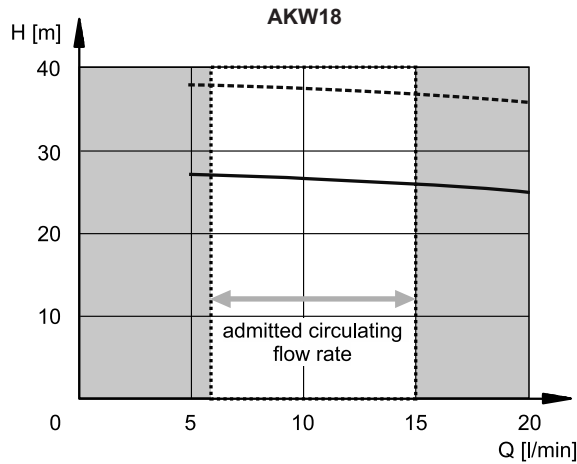

— 50 Hz  
- - - 60 Hz

### 14.2 - M-type pump

The diagrams show the performance curves of AKW chillers with the dual-frequency M-type pump at 50 Hz and 60 Hz, with water as the heat transfer fluid. When using a water-glycol emulsion, the flow rate will be lower at the same head.

Select the pipe diameter and length to keep the circulating flow within the allowable range.

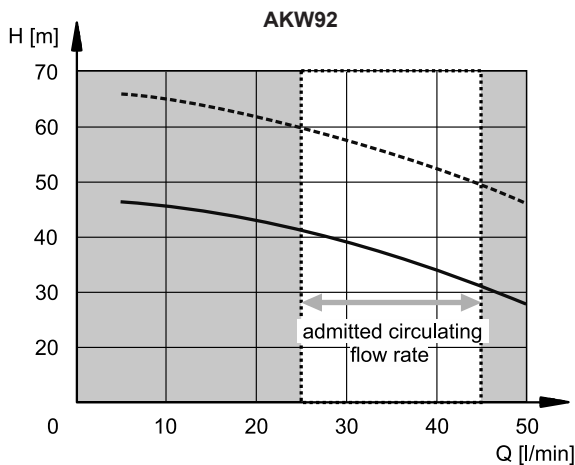
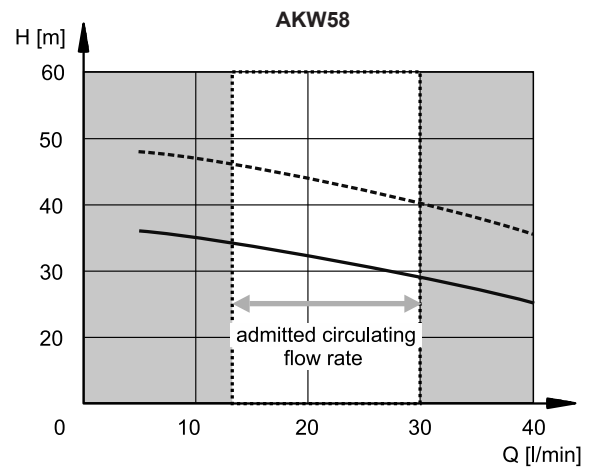
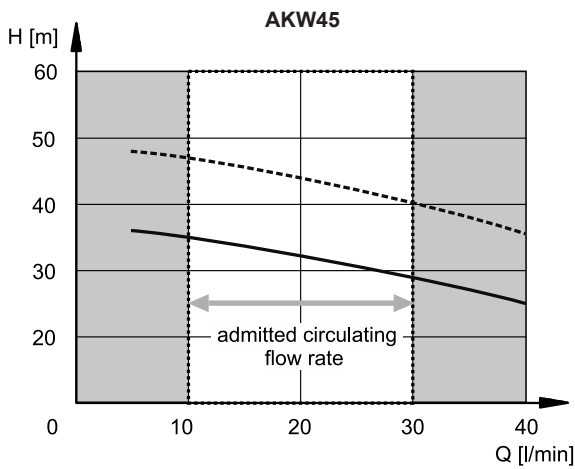
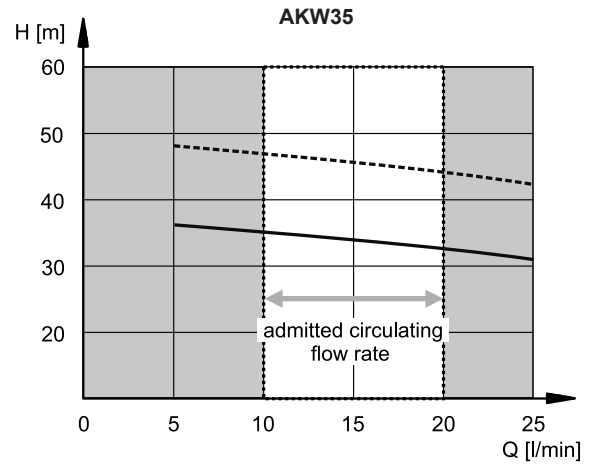
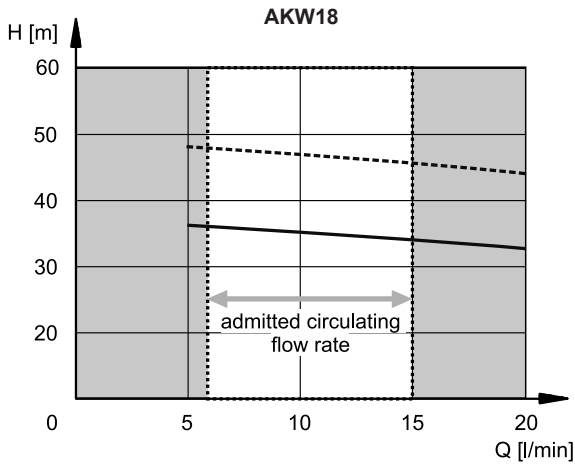

— 50 Hz  
 - - - 60 Hz

## 15 - OVERALL DIMENSIONS AND MOUNTING - CONFIGURABLE MODELS WITH INTEGRATED PUMP AND TANK

### 15.1 - AKW18ACD00J/P, AKW35ACD00J/P and AKW45ACD00J/P

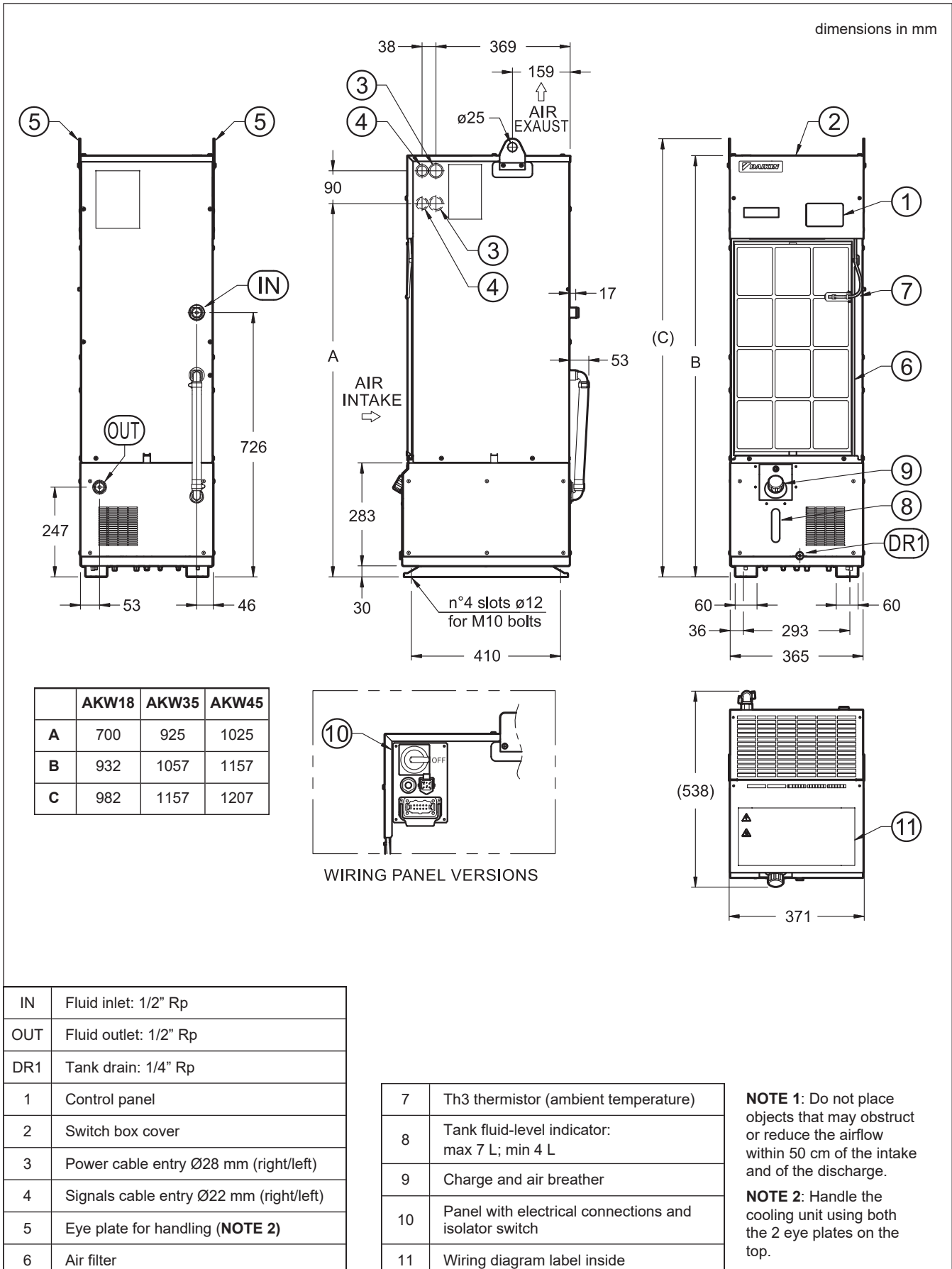

15.2 - AKW58ACD\*0J/P

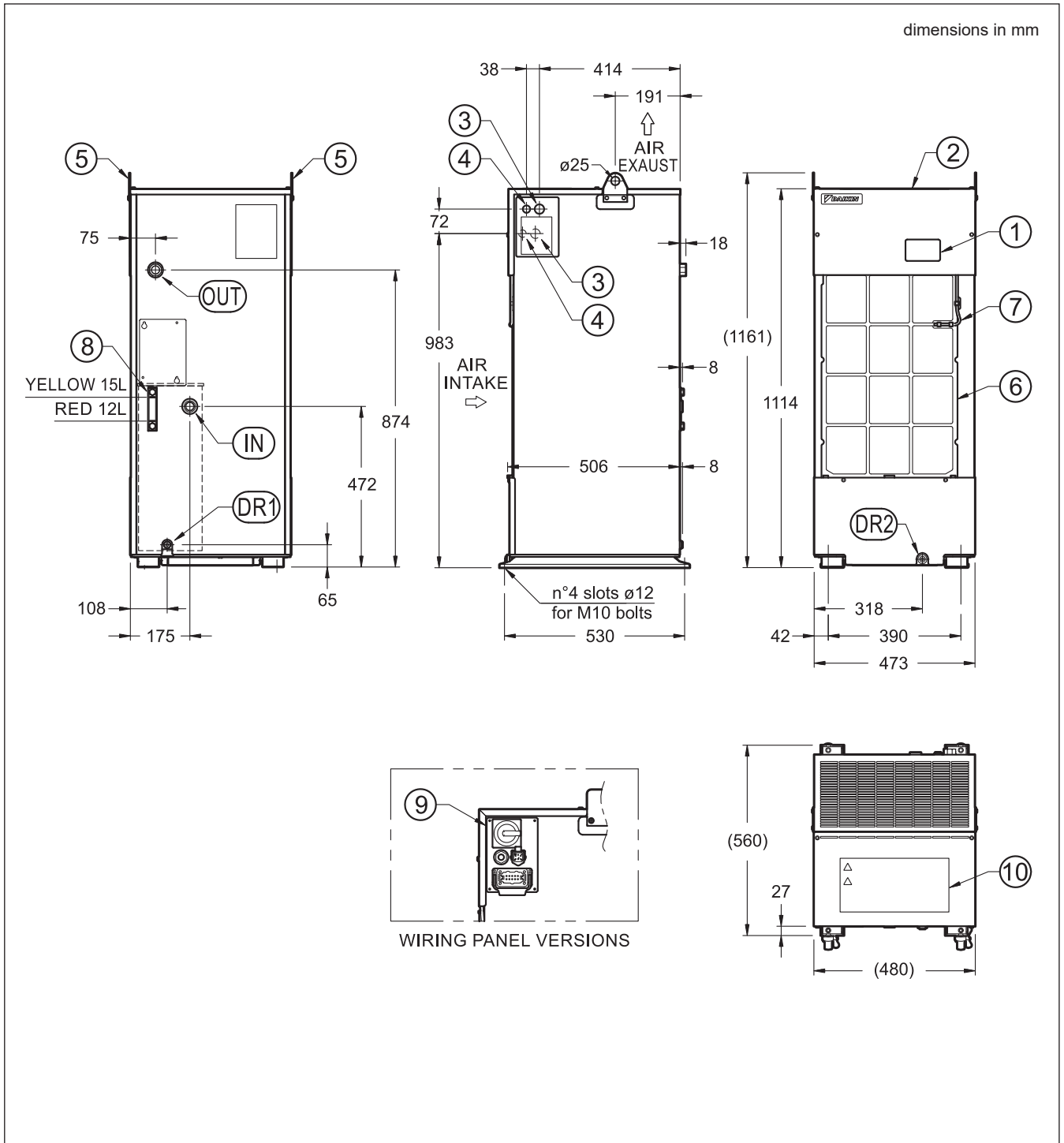

IN	Fluid inlet: 3/4" Rp
OUT	Fluid outlet: 3/4" Rp
DR1	Tank drain: 3/8" Rc (plugged)
DR2	Drain pan: 3/8" Rc (plugged)
1	Control panel
2	Switch box cover
3	Power cable entry Ø28 mm (right/left)
4	Signals cable entry Ø22 mm (right/left)

5	Eye plate for handling ( <b>NOTE 2</b> )
6	Air filter
7	Th3 thermistor (ambient temperature)
8	Tank fluid-level indicator: max 15 L; min 12 L
9	Panel with electrical connections and isolator switch
10	Wiring diagram label inside

**NOTE 1:** Do not place objects that may obstruct or reduce the airflow within 50 cm of the intake and of the discharge.

**NOTE 2:** Handle the cooling unit using both the 2 eye plates on the top.

15.3 - AKW92ACD\*0J/P

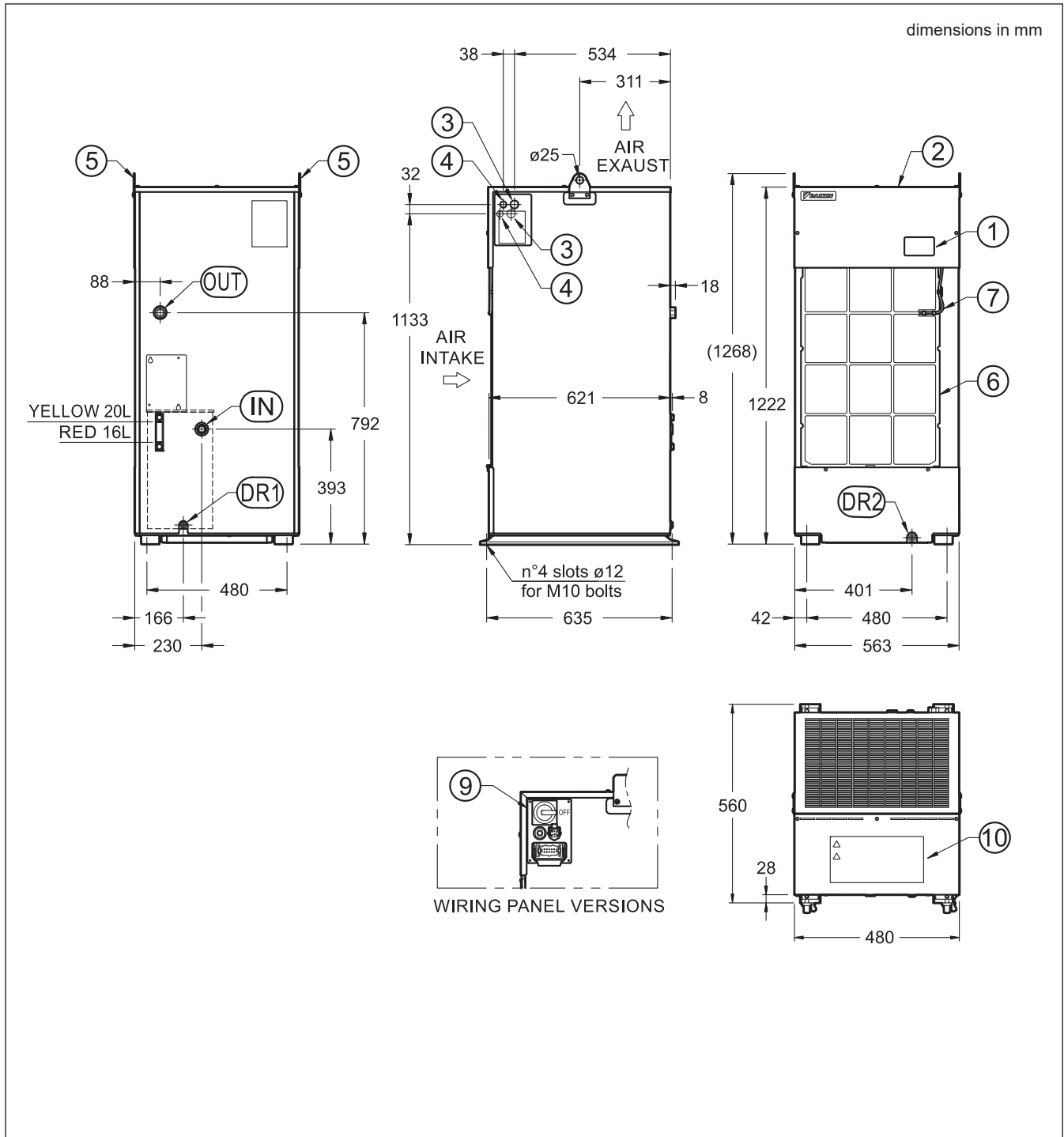

IN	Fluid inlet: 3/4" Rp
OUT	Fluid outlet: 3/4" Rp
DR1	Tank drain: 3/8" Rc (plugged)
DR2	Drain pan: 3/8" Rc (plugged)
1	Control panel
2	Switch box cover
3	Power cable entry Ø28 mm (right/left)
4	Signals cable entry Ø22 mm (right/left)

5	Eye plate for handling ( <b>NOTE 2</b> )
6	Air filter
7	Th3 thermistor (ambient temperature)
8	Tank fluid-level indicator: max 15 L; min 12 L
9	Panel with electrical connections and isolator switch
10	Wiring diagram label inside

**NOTE 1:** Do not place objects that may obstruct or reduce the airflow within 50 cm of the intake and of the discharge.

**NOTE 2:** Handle the cooling unit using both the 2 eye plates on the top.

## 16 - ELECTRICAL CONNECTIONS

Below are the instructions for the models with the panel featuring a switch and plug-in sockets (code S). For models with a direct connection to the internal terminal block of the cooling unit's electrical panel (code 0), refer to the wiring diagram on page 10.

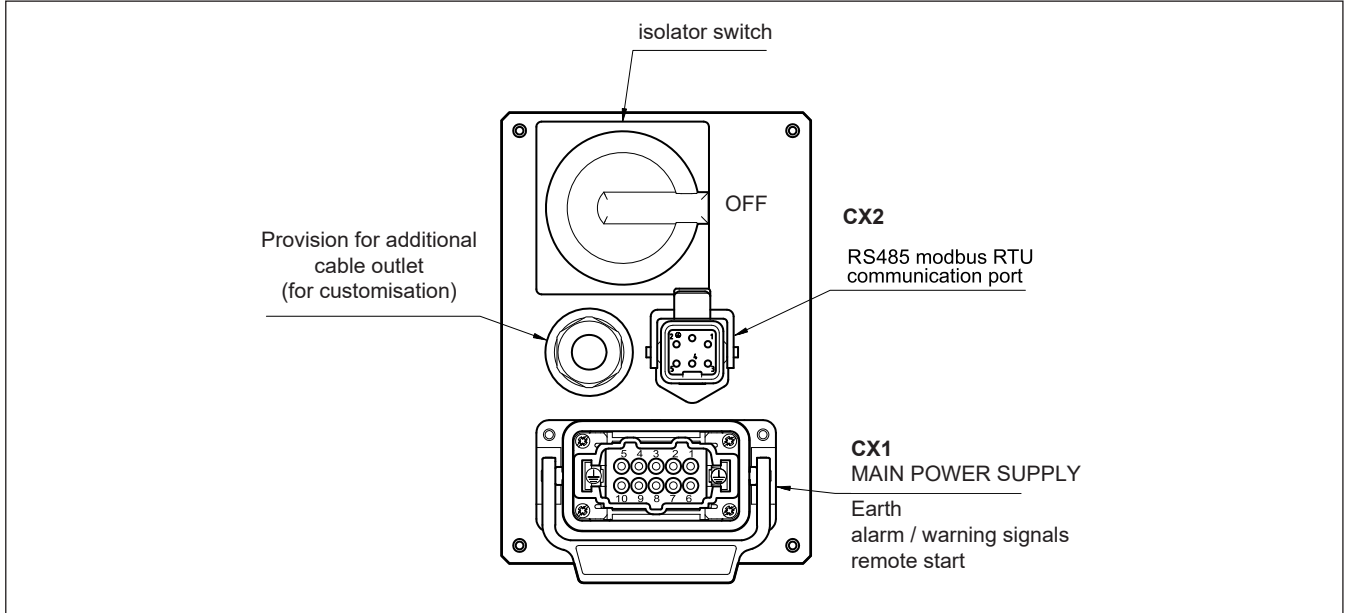

### 16.1 - Pinout of CX1 socket

The plug is supplied.

internal AKW pin		CX1	cable	description
M5 screw		<b>PE</b>	6 mm <sup>2</sup>	Earth
L1 (X1M)		<b>1</b>	6 mm <sup>2</sup>	Main Power Supply Three-phase AC 380/400/415 V 50/60 Hz ±10%
L2 (X1M)		<b>2</b>		
L3 (X1M)		<b>3</b>		
-		<b>4</b>	NC	-
60 (X2M)		<b>5</b>	0.75 mm <sup>2</sup>	Normal Operation (RUN) Min load: 5V DC, 1 mA - Max load: 24V 1A
61 (X2M)		<b>6</b>		
66 (X2M)		<b>7</b>	0.75 mm <sup>2</sup>	Warning Signal Output (LOCK) Min load: 5V DC, 1 mA - Max load: 24V 1A
67 (X2M)		<b>8</b>		
10 (X2M)		<b>9</b>	1 mm <sup>2</sup>	Remote Start (Optional upon request)
11 (X2M)		<b>10</b>		

### 16.2 - Pinout of CX2 socket

The plug can be ordered separately; see point 23.

internal AKW pin		CX2	cable	description
		<b>PE</b>	NC	-
1 (X3M)		<b>1</b>	1 mm <sup>2</sup>	Communication with main machine using Modbus RTU protocol RS485 serial interface
2 (X3M)		<b>2</b>		
3 (X3M)		<b>3</b>		
4 (X3M)		<b>4</b>		
5 (X3M)		<b>5</b>		

## 17 - IDENTIFICATION CODE - CONFIGURABLE MODELS WITH EXTERNAL PUMP AND TANK

<b>AK</b>	<b>W</b>	<b>A</b>	<b>CD</b>	<b>00</b>	<b>J / G</b>	<b>I -</b>	<b>0 - K****</b>
-----------	----------	----------	-----------	-----------	--------------	------------	------------------

High-accuracy inverter controlled cooling unit

For water and water-glycol emulsions < 30% vol

Cooling capacity (50/ 60 Hz)

**18** = 1.8 kW  
**35** = 3.5 kW  
**45** = 4.5 kW  
**58** = 5.8 kW  
**92** = 9.2 kW

**A** = series 10

Power supply:  
 3-phase AC 380 V / 400 V / 415 V 50/60 Hz  
 According to EC directives

Frame model with immersed pump and stainless steel tank.

With RS485 Modbus RTU communication protocol

Project code for customisation (assigned by Diplomatic) **(NOTE 1)**

Other options

Electrical connections  
**0** = to be wired to terminal block  
**S** = with plug-in sockets and external isolator switch

Stainless steel tank

Pump head:  
**L** = low pressure 2 bar  
**M** = medium pressure 4 bar  
**H** = high pressure 5 - 10 bar

Immersed pump, vertical mounting

**NOTE 1: Customised Options**

The cooling unit can be customised according to the customer's requirements by liaising with the pre-sales service.

Customisations include the installation of optional protection devices (flow switch, level switch, pressure gauge on pump outlet), castors, Rc / BSP adapter fittings, wiring of optional thermistors supplied by us, and programming different from the factory standard.

Separately available for purchase are: the plug for the Modbus communication socket, adapter fittings, long-life filters, and the cable kit for connection with Hybrid Win software. See catalog 90 661 - AK\* ACCESSORIES.

## 18 - SPECIFICATIONS FOR CONFIGURABLE MODELS WITH EXTERNAL PUMP AND TANK

		AKW18	AKW35	AKW45	AKW58	AKW92
Power supply		AC three-phase 380/400/415 V 50/60 Hz				
Motor pump (400 V 60 Hz)		0.55 kW x 2P				
Circulating volume rated range	l/min	10 6 ÷ 15	15 10 ÷ 20	15 10 ÷ 30	25 13 ÷ 30	40 25 ÷ 45
Nominal head: L-type pump M-type pump H-type pump	m	25 58 78				
Max ambient temperature	°C	40				
Tank volume	l	10			20	
Transportation weight	kg	63	68	69	109	137

### 18.1 - Circuit diagrams

The diagram in point 13.1 is valid for all the sizes of the chillers.

## 19 - CHARACTERISTICS OF THE CONFIGURABLE MODELS WITH EXTERNAL PUMP AND TANK

Values obtained and rated for standard point with standard pump model, ambient temperature: 25 °C and fluid temperature: 25 °C. Fluid used: H<sub>2</sub>O.

### 19.1 -Temperature control

Cooling capacity (kW) according to the ambient temperature.

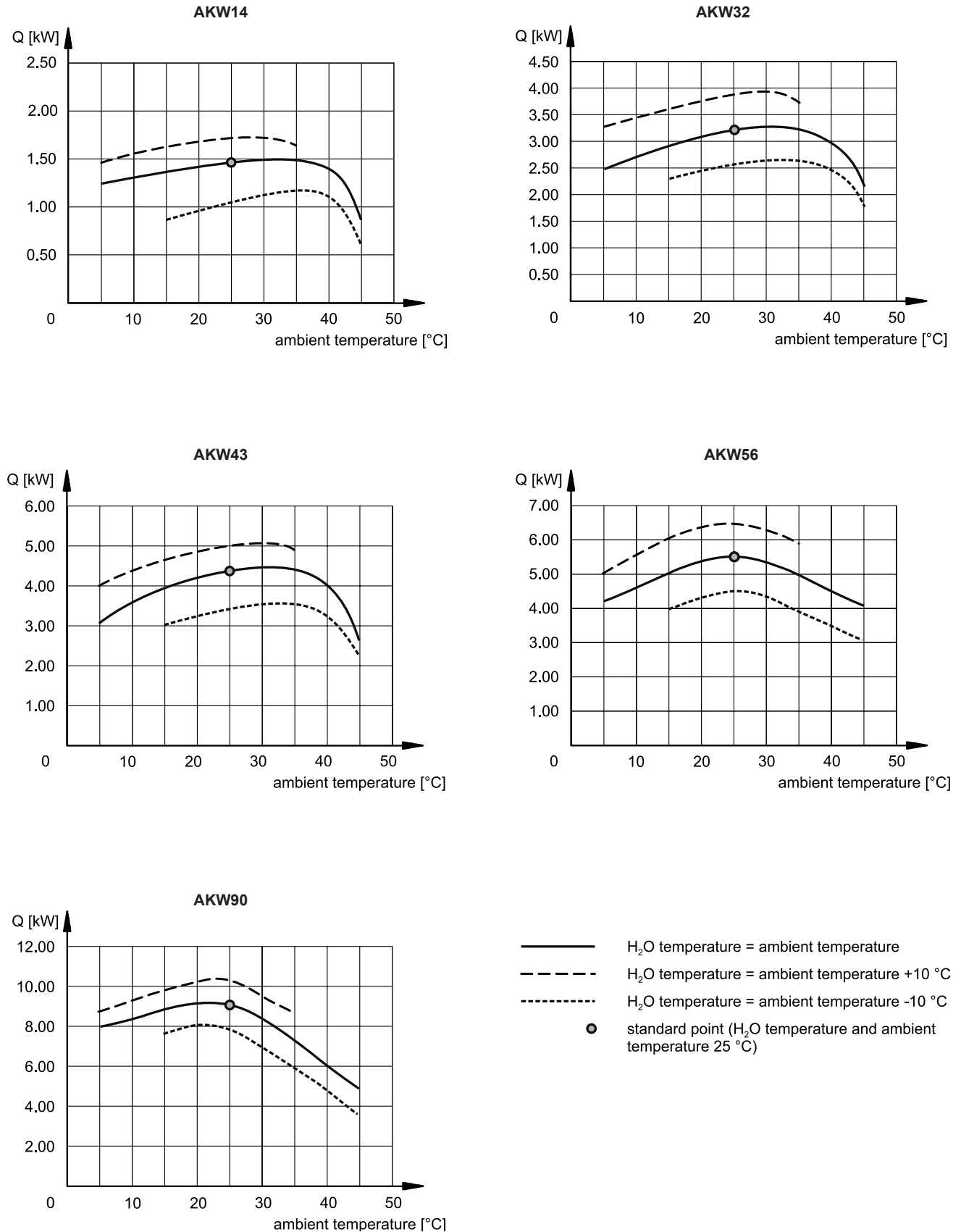

### 19.2 - Pump flow characteristics (type L)

The diagrams show the performance curves of AKW chillers with type L immersion pumps at 20 °C and 50 Hz, with water-glycol emulsion as the heat transfer fluid.

Select the pipe diameter and length to keep the circulating flow within the allowable range. Flow characteristics outside the standard specifications can also be supported.

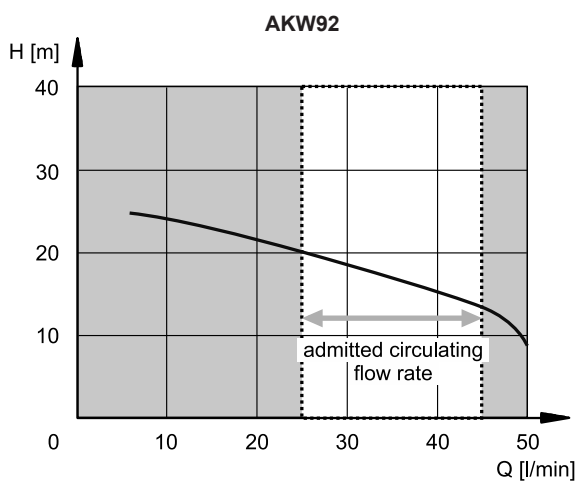
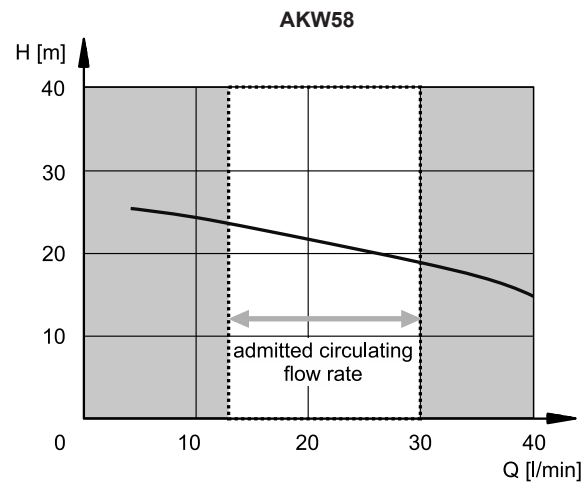
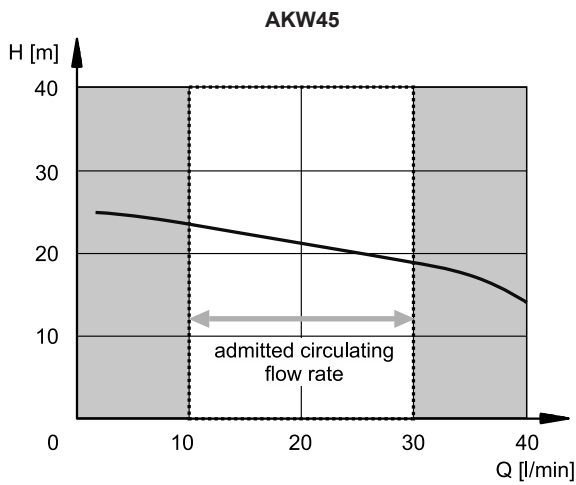
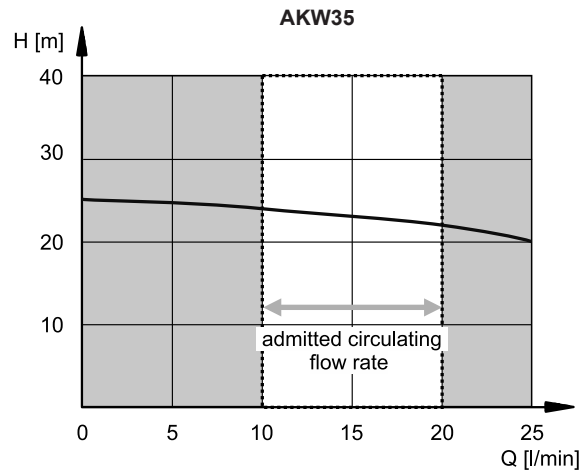
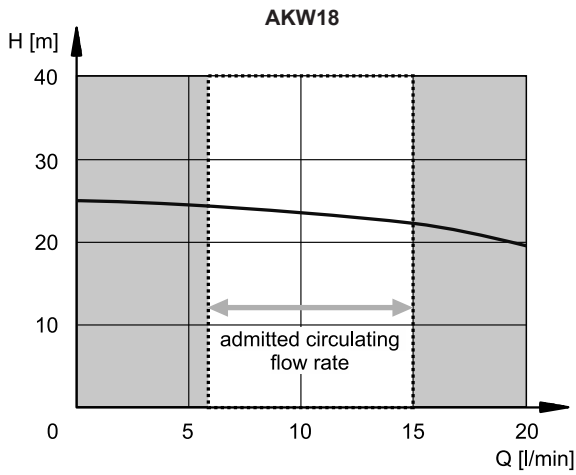

**19.3 - Pump flow characteristics (type M)**

The diagrams show the performance curves of AKW chillers with type M immersion pumps at 20 °C and 50 Hz, with water-glycol emulsion as the heat transfer fluid.

Select the pipe diameter and length to keep the circulating flow within the allowable range. Flow characteristics outside the standard specifications can also be supported.

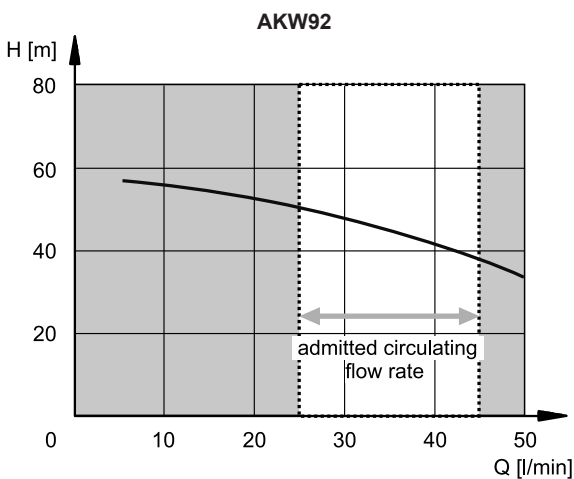
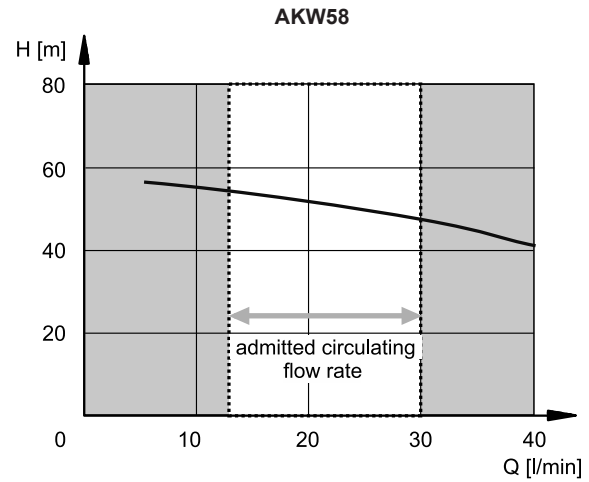
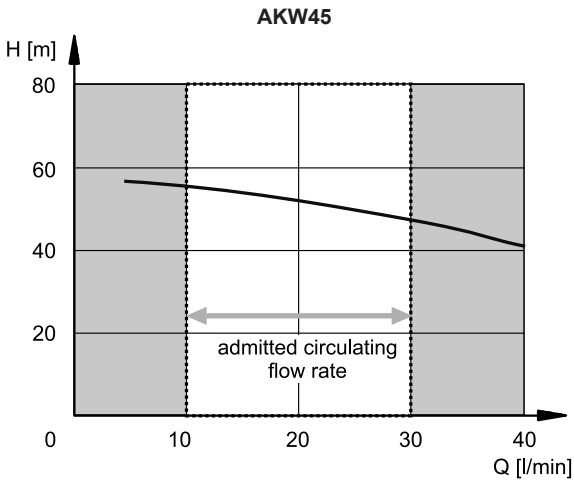
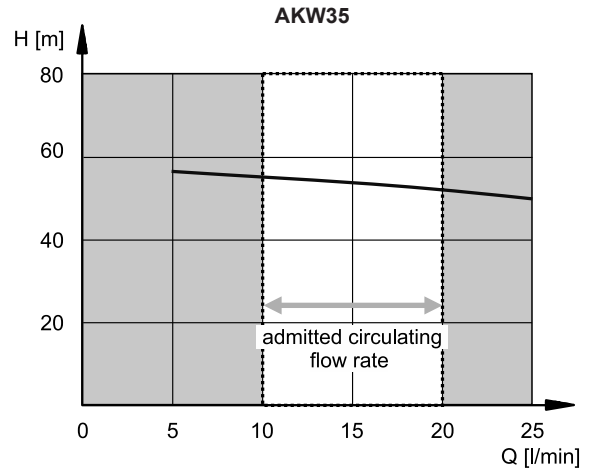
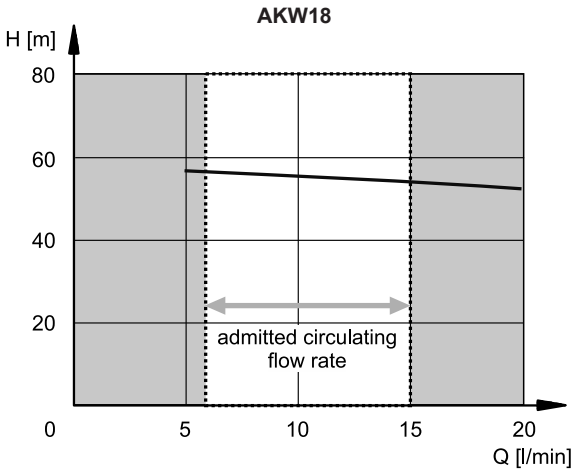



### 19.4 - Pump flow characteristics (type H)

The diagrams show the flow characteristics of type H immersion pumps at 20°C and 50 Hz, with water-glycol emulsion.

Select the pipe diameters and lengths to keep the circulation volume within the permitted limits. Flow characteristics outside the standard specifications can also be supported.

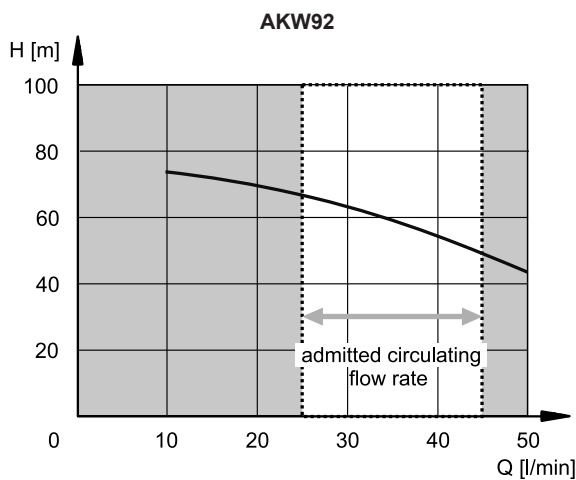
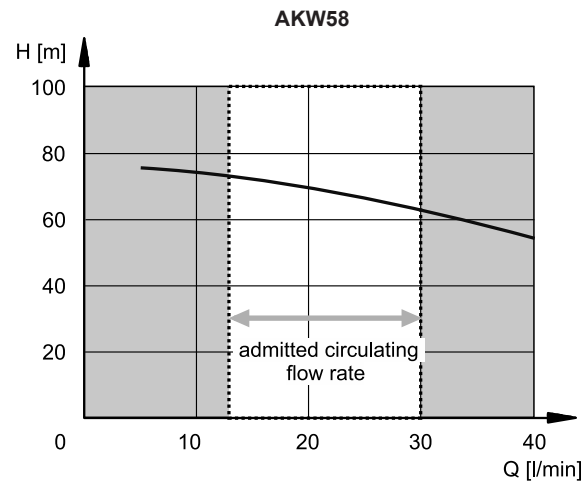
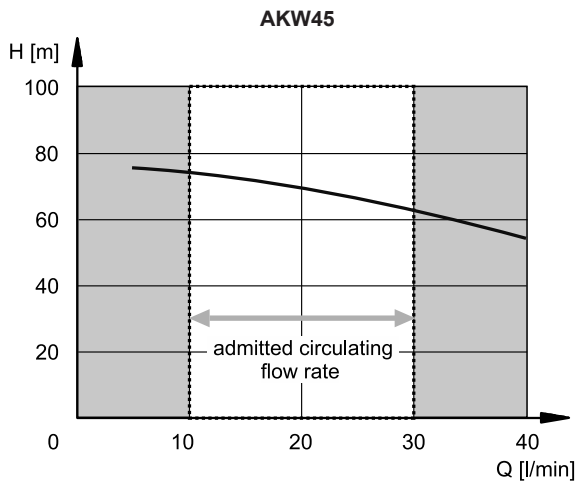
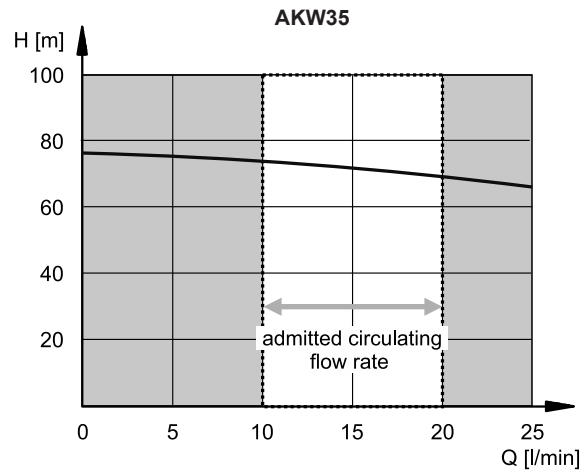
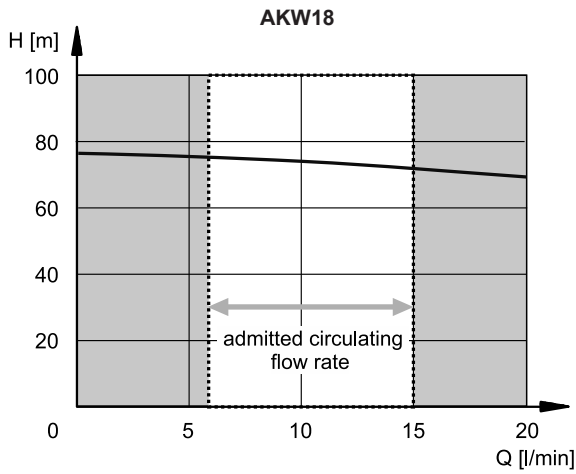



20.2 - AKW58ACD00J/G

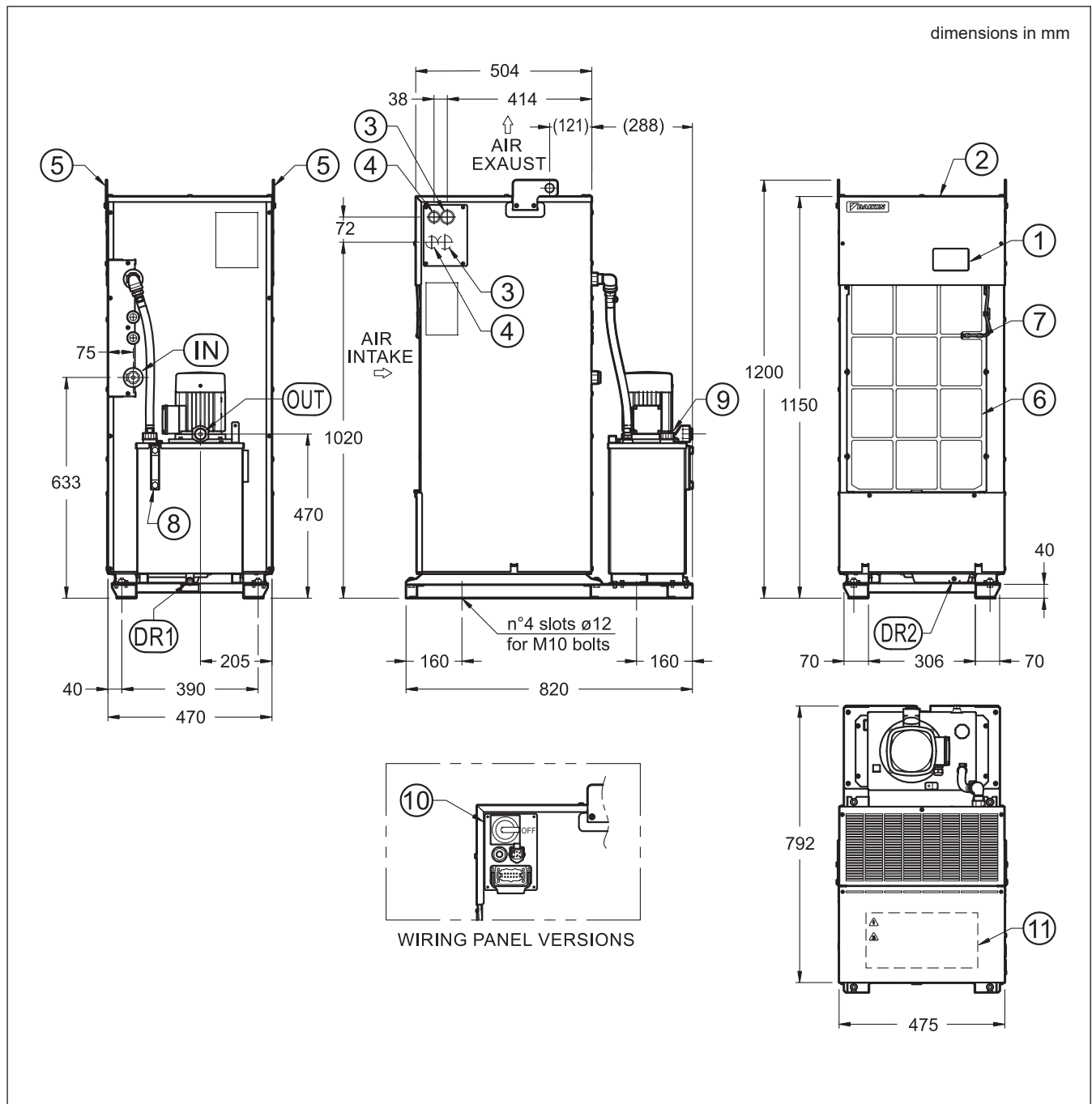

IN	Fluid inlet: 3/4" Rp
OUT	Fluid outlet: 3/4" Rp
DR1	Tank drain: 3/8" Rc
DR2	Drain pan (M6 plugged)
1	Control panel
2	Switch box cover
3	Power cable entry Ø28 mm (right/left)
4	Signals cable entry Ø22 mm (right/left)
5	Eye plate for handling ( <b>NOTE 2</b> )
6	Air filter

7	Th3 thermistor (ambient temperature)
8	Tank fluid-level indicator: max 20 L; min 16 L
9	Charge and air breather
10	Panel with electrical connections and isolator switch
11	Wiring diagram label inside

**NOTE 1:** Do not place objects that may obstruct or reduce the airflow within 50 cm of the intake and of the discharge.

**NOTE 2:** Handle the cooling unit using both the 2 eye plates on the top.

20.3 - AKW92ACD00J/G

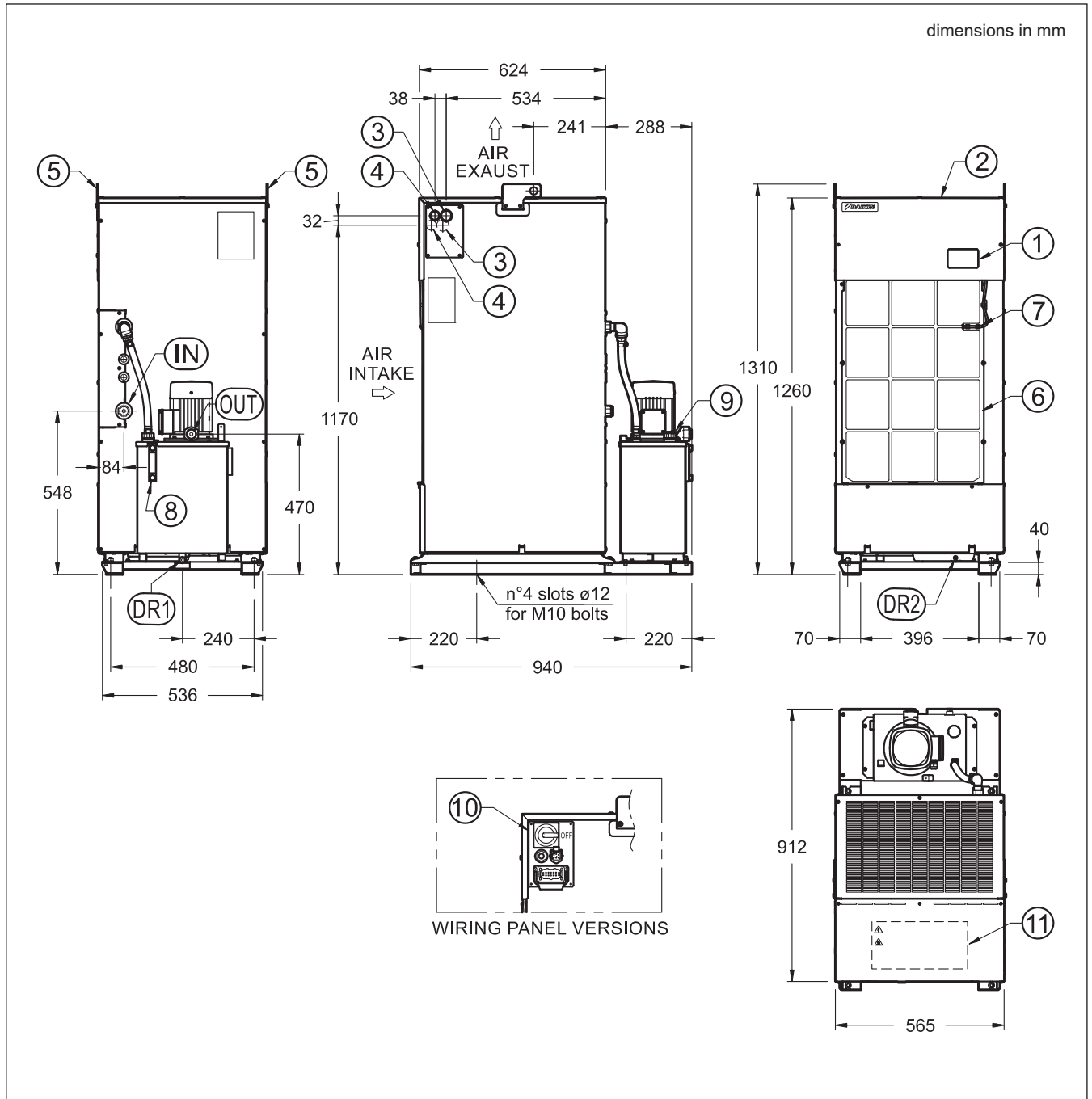

IN	Fluid inlet: 3/4" Rp
OUT	Fluid outlet: 3/4" Rp
DR1	Tank drain: 3/8" Rc
DR2	Drain pan (M6 plugged)
1	Control panel
2	Switch box cover
3	Power cable entry Ø28 mm (right/left)
4	Signals cable entry Ø22 mm (right/left)
5	Eye plate for handling ( <b>NOTE 2</b> )
6	Air filter

7	Th3 thermistor (ambient temperature)
8	Tank fluid-level indicator: max 20 L; min 16 L
9	Charge and air breather
10	Panel with electrical connections and isolator switch
11	Wiring diagram label inside

**NOTE 1:** Do not place objects that may obstruct or reduce the airflow within 50 cm of the intake and of the discharge.

**NOTE 2:** Handle the cooling unit using both the 2 eye plates on the top.

## 21 - ELECTRICAL CONNECTIONS

For models with a panel featuring plug-in sockets and an isolator switch (code S), refer to the electrical connections illustrated in point 16. For models with direct connections to the terminal block inside the refrigerant unit's electrical panel (code 0), refer to the wiring diagram shown in point 10.

## 22 - DEVICE SETUP

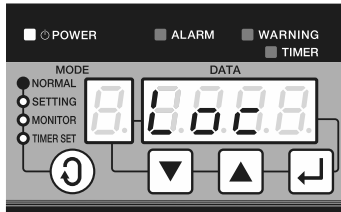

The AKW cooling units are configurable via the display, from which it is always possible to set and monitor parameters and alarms. AKW cooling units allow also the remote control from the main machine control board.

As the machine is preset to LOCK mode (STOP mode) at the time of factory shipment, carry out the unlocking operation via the control panel. Unlocking method is given in the *Instruction Manual*.

## 23 - ACCESSORIES

### 23.1 - Hybrid-win software

The software allows real-time monitoring of operating data via a graphical interface. It must be installed on devices running the Microsoft Windows operating system.

The connection is made via wiring, directly to the main board inside the cooling unit. The AKPC cable kit (comprising a USB converter, special cable, and wiring) must be ordered separately. For details, please refer to catalogue 90 661.

The Hybrid-win software can be easily downloaded from the product page on Diplomatic MS's website: Accessories for cooling units.

### 23.2 - Other accessories

Accessories are sold separately, and their installation on the cooling unit/main machine is the responsibility of the customer. For details on thermistors, long-life filters, fittings, castors, and cable kit for the Hybrid-win software, refer to catalogue 90 661 - ACCESSORIES FOR AK\* COOLING UNITS.

## 24 - INSTALLATION NOTES

### 24.1 - Handling, machine side

- When rough transport conditions are expected, special precautions should be taken in the packaging and transportation method so as to avoid the application of excessive force on the cooling unit.
- The cooling unit does not include a flow switch for monitoring the fluid supply or a temperature switch for detecting abnormal temperatures (high or low) of the supplied fluid. Therefore, please ensure that protection devices such as a flow switch and a temperature switch are provided on the machine side.

### 24.2 - Operation and cooling capacity

- Before starting the unit, ensure that you have carefully read and fully understood the Instruction Manual
- Do not start the cooling unit if the fluid temperature exceeds 45 °C. Start the cooling unit either simultaneously with the main machine or before the fluid temperature reaches 40 °C.
- **Do not obstruct the airflow within 50 cm of the air intake or outlet.**
- If the air filter is clogged, the cooling capacity will be reduced. Clean the air filter periodically (by washing it with lukewarm water or cleaning it with air) at least every two weeks to prevent clogging. If a long-life filter is installed, replace the filter element and empty the drain pan at least once a year, or whenever the cooling capacity significantly decreases.

## 25 - INSTRUCTION FOR SAFE OPERATION

### General Instructions

- Use the equipment only in accordance with the specified guidelines (as detailed in the brochure, specification sheet, operation manual, and caution plates).
- Never operate the equipment in an explosive atmosphere.
- Do not disassemble, repair or modify the equipment by yourself.
- Always comply with safety regulations (e.g., Industrial Safety and Health Law, Fire Defense Law).
- Caution in the event of a refrigerant leak:
  - Adequately ventilate the area (to avoid the risk of suffocation)
  - Avoid direct contact with refrigerant to prevent cryogenic burns.
  - If a large quantity of refrigerant is inhaled, or if refrigerant comes into contact with skin or eyes, seek medical attention immediately.
- If an abnormal condition arises, stop the unit immediately, investigate the cause, and take corrective measures.
- Do not use the unit outdoors or in environments with extreme conditions (e.g., high temperatures, high humidity, excessive dust, contaminants, steam, oil mist, or corrosive gases such as H<sub>2</sub>S, SO<sub>2</sub>, NO<sub>2</sub> or Cl<sub>2</sub>).
- Install a flow switch and a temperature switch on the machine to protect the spindle and other components.
- Do not climb on the unit or place objects on it.
- The unit is designed for use up to an altitude of 2,000 meters. At altitudes over 1,000 meters, the cooling capacity decreases by approximately 20-30%. Ensure that you select a model with adequate cooling capacity margin.

### Instructions for Transportation

- When hoisting the equipment, check its weight and use the eye plates and hangers on it properly.
- When hoisting the equipment, do not do so while it is fitted with a tank or anything else that you have provided.
- Never approach the unit during hoisting and transportation.
- When moving the equipment, take appropriate measures for fall prevention.
- Do not tilt the equipment more than 30°.

### Instructions for Installation

- Install the unit on a stable, flat surface and secure it properly.
- Do not place any objects near the air intake or exhaust ports.

### Instructions for Wiring and Piping Installation

- Wiring and piping should be carried out by qualified personnel.
- Always use a commercial power supply: using an inverter power supply may cause damage due to overload.
- Connect the power supply wiring according to the procedure outlined in the wiring diagram provided in the specification sheets and operation manual.
- Ensure that the unit is properly grounded.
- Install the wiring in accordance with the relevant standards and verify the wiring diagram.
- Install a dedicated all-pole (3-pole) earth leakage breaker, sized appropriately for the cooling unit's capacity, at the main power supply.

- Verify that the fluid piping has a pressure rating of 10 bar or more, and install it accordingly.

### Instructions for Trial Run

- Check that the machine is in a safe status (not activated) before starting the trial run.
- Check that the oil piping and electric wiring are correctly connected to the machine and that there is no leakages in connections and joints.
- Disable the operation lock of the cooling unit before starting the main machine.
- Check that the fluid piping system contains the required amount of fluid, and that the piping is not blocked part way through.

### Instructions During Operation

- Do not splash water or liquid on the cooling unit.
- Do not insert fingers or any foreign objects into the cooling unit's fins.
- Do not touch the heated exhaust port of the cooling unit.

### Instructions for Maintenance and Inspection

- Perform maintenance and inspections in a well-ventilated area. Working in a confined space may lead to suffocation in the event of refrigerant leakage.
- Always turn off the main power supply before starting maintenance or inspection.
- **Wait at least five minutes** after disconnecting the power supply before beginning maintenance work..
- Do not operate the unit with the electrical panel cover or any other covers open.
- Wear appropriate protective clothing, such as gloves and eye protection, during maintenance, inspection, and cleaning
- Clean the air filter periodically (typically every two weeks).
- Ensure that the water quality and fluid concentration consistently meet the required standards
- Check the fluid level in the tank and ensure it is between the yellow and red lines on the indicator.
- Inspect the drain pan underneath the cooling unit every six months. If any fluid has accumulated, drain it through the drainage port.

### Selection Method for Cooling Units

- Select a cooling unit with a cooling capacity 20-30% greater than the heat generated by the machine tool.
- When selecting the appropriate cooling unit, consider both the ambient temperature and desired fluid temperature, as these factors will affect the cooling capacity of the unit.



**AKW**  
SERIES A

**DIPLOMATIC**  
MOTION SOLUTIONS  
*a member of **DAIKIN** group*

**DIPLOMATIC MS Spa**

via Mario Re Depaolini, 24 | 20015 Parabiago (MI) | Italy

T +39 0331 895111 | E vendite.ita@diplomatic.com | sales.exp@diplomatic.com

diplomaticmotionsolutions.com